



KAN-therm
MULTISYSTEM

> 35 | years of experience
on the installation
market

Guidebook

DESIGNER AND CONTRACTOR





























Install the **future**

EN 26/04

kan-therm.com





Complete multipurpose installation system consisting of modern, mutually complementary technical solutions for pipe water distribution, heating and cooling installations, as well as technological and fire extinguishing ones.



COLOUR SYSTEM							
							
SYSTEM NAME		ultra LINE	ultra PRESS	PP	Steel	Inox	Copper
DIAMETER RANGE [mm]		14-32	16-63	16-110	12-108	12-168,3	12-108
INSTALLATIONS TYPE							
	TAP WATER	●	●	●		●	●
	HEATING	●	●	●	●	●	●
	TECHNOLOGICAL HEAT	○	○	○	○	○	
	SOLAR				○	○	
	COOLING	○	○	○	○	●	●
	COMPRESSED AIR	○	○	○	○	○	○
	TECHNICAL GASES	○	○	○	○	○	○
	FLAMMABLE GAS						
	TECHNICAL OILS				○	○	○
	INDUSTRIAL				○	○	
	BALNEOLOGICAL			○		○	
	SPRINKLER FIRE-FIGHTING						
	HYDRANT FIRE-FIGHTING						
	UNDERFLOOR HEATING AND COOLING	●	●				
	WALL HEATING AND COOLING	●	●				
	CEILING HEATING AND COOLING	●	●				
	EXTERNAL SURFACES HEATING AND COOLING	●	●				

In untypical cases, it is necessary to check the conditions of using KAN-therm parts with technical and information materials or opinions of the KAN Technical Department. Use the form – Inquiry about the possibility to use KAN-therm elements – to send basic parameters of an installation operation. Based on the data sent, the Technical Department will assess the fitness of the system to the particular installation. The form can be found on the website.



	
Surface heating and cooling	Cabinets, manifolds
12-25	–

	○
●	●
	○
○	○
●	●
●	●
●	●
●	●

		
Copper Gas	Steel XPress Sprinkler	Inox XPress Sprinkler
15-54	22-108	22-108

		○
○	○	○
○	○	○
●		
	●	●
	●	●

- standard scope of application
- possible use – the conditions to be confirmed with the KAN Technical Department



About KAN

Modern water and heating solutions

KAN was established in 1990 and has been implementing state of the art technologies in heating and water distribution solutions ever since.

KAN is European recognized leader and supplier of state of the art KAN-therm solutions and installations intended for indoor hot and cold tap water installations, central heating and floor heating installations, as well as fire extinguishing and technological installations. Since the beginning of its activity, KAN has been building its leading position on such values as professionalism, innovativeness, quality and development. Today, the company employs over 1200 people, a great part of which are specialist engineers responsible for ensuring continuous development of the KAN-therm system, all technological processes applied and Customer service. The qualifications and commitment of our personnel guarantees the highest quality of products manufactured in KAN factories.

KAN has a branch network in Poland and international offices around the world. The products with the label KAN-therm are exported to 65 countries on different continents. The distribution chain covers Europe and a significant part of Asia, Africa and America.

The KAN-therm system is an optimal, complete multipurpose installation system consisting of state of the art, mutually complementary technical solutions for pipe water distribution installations, heating installations, as well as technological and fire extinguishing installations. It is the materialization of a vision of a universal system, the fruit of extensive experience, the passion of KAN's constructors, as well as strict quality control of our materials and final products.

INTRODUCTION

KAN-therm is a complete installation system for constructing internal water supply, heating distribution and technological networks. The system comprises state of the art, mutually complementary solutions for installation materials and connection technologies.

The “KAN-therm MULTISYSTEM Guidebook for Designers and Contractors” is dedicated to all participants of the construction processes involving state-of-the-art installations – designers, installers and construction site inspectors.

Our Guide presents a wide range of solutions and installation techniques, as well as a comprehensive presentation of the most modern and popular installation systems collectively forming the KAN-therm multisystem. Such a presentation gives the user an opportunity to learn and compare available systems and, finally, to select the most suitable installation solution, in terms of technology, economics and usability.

This guide has been written in compliance with all basic, European standards and guidelines regarding water and heating distribution systems in the construction industry.

The guide has been divided into three basic parts:

- part I, presenting the characteristics of eight KAN-therm piping installation systems,
- part II, presenting common guidelines for designing and assembling these systems,
- part III, discussing the basic principles of dimensioning KAN-therm installations.

The “product” part consists of chapters discussing particular installation systems:

- **KAN-therm ultraLINE system** based over three variants of pipes (PEXC, PERT² and PERTAL²), two material variants of fittings (brass and PPSU) fittings together by a sliding PVDF sleeve,
- **KAN-therm ultraPRESS system** with PERTAL pipes, two material variants of fittings (PPSU and brass) joined by radial pressing technique,
- **KAN-therm PP system** consisting of PP-R polypropylene pipes and fittings, PP-RCT pipes as well as polypropylene compound pipes stabiGLASS PPR,
- **KAN-therm Steel** and **KAN-therm Inox system** consisting of carbon steel and stainless steel pipes and fittings joined in radial press technique.
- **KAN-therm Copper system** based over radially pressed fittings made of copper and bronze for connecting standard copper pipes.

Apart from a description of pipes and fittings, dimension data and scope of use, each of the above mentioned chapters contains guidelines for executing joints, which are characteristic for each installation system.

Information materials consisting **other products, such as KAN-therm XPress Sprinkler, KAN-therm Copper Gas** and the **KAN-therm Surface heating/cooling systems** have been included in separate guides due to their different application specifications.

For designers using traditional methods of installation dimensioning, we provide an appendix containing a separate set of tables presenting the hydraulic properties of pipes and fittings described in the system Guide, taking into account the typical operating parameters of water supply and heating installations. Apart from the Guide, we offer all designers a free suite containing professional design programs: **KAN SET, KAN OZC, KAN C.O. Graf and KAN H2O.**

All elements with a KAN-therm mark are subject to a very strict quality control system, e.g. in our state of the art research and development laboratory.

The KAN Laboratory, thanks to the use of the latest technological achievements in the field of installation systems testing, has been accredited by Western certification bodies and its results are recognized by the largest of them.

Our production process, as well as our entire activity, is supervised by the ISO 9001 quality control system, a certified by a reputable institution Lloyd's Register Quality Assurance Limited.

Table of contents

SYSTEM **KAN-therm** ultraLINE

1	The idea behind the system	17
2	Advantages of KAN-therm ultraLINE system	18
3	Pipes in the KAN-therm ultraLINE system	18
3.1	Assortment of pipes in KAN-therm ultraLINE system.....	18
3.2	Construction and properties of KAN-therm ultraLINE system pipes.....	20
3.3	Operational parameters of KAN-therm ultraLINE system pipes.....	25
4	Fittings and sliding sleeves in KAN-therm ultraLINE system	26
4.1	Fittings in the KAN-therm ultraLINE system.....	26
4.2	Sliding sleeves in the KAN-therm ultraLINE system.....	27
4.3	Advantages of fittings and sliding sleeves design.....	28
5	Connections in the KAN-therm ultraLINE system	28
5.1	Connections with a sliding sleeve.....	28
5.2	Threaded connections in KAN-therm ultraLINE system.....	29
5.3	Threaded connections using fittings with nickel-plated pipes of the KAN-therm ultraLINE system.....	30
6	Contact with substances containing solvents, sealing the threads	31
7	Tools for installation of KAN-therm ultraLINE system	32
7.1	Configuration of tools for installation of KAN-therm ultraLINE system.....	32
7.2	Completing KAN-therm ultraLINE system tools.....	37
7.3	Advantages of KAN-therm ultraLINE system tools.....	37
7.4	Safety when using tools.....	37
8	Assembly of KAN-therm ultraLINE system connections	38
8.1	Assembly of connections with a sliding sleeve.....	38
8.2	Installation of universal threaded couplings and threaded connectors.....	40
8.3	Installation of universal eurocone adapters.....	41
8.4	Assembly of adapters for metal pipes.....	41
9	Transport and storage	42

Table of contents

SYSTEM **KAN-therm** ultraPRESS

1	General information	45
2	Pipes in the KAN-therm ultraPRESS	46
2.1	PERTAL pipes with aluminum layer	46
2.2	PEXC, PERT and bluePERT pipes with EVOH layer and bluePERTAL with aluminium layer	48
2.3	Scope of use	50
3	Joints in multilayer installations with KAN-therm pipe with aluminium layer	51
3.1	„Press“ joints	51
3.2	Structure and features of KAN-therm 16-40 mm ultraPRESS fittings	52
3.3	Identification of KAN-therm ultraPRESS fittings	53
3.4	KAN-therm ultraPRESS fittings with diameters 50 and 63 mm	53
3.5	KAN-therm pressed fittings – assortment	54
3.6	Contact with chemicals, adhesives and sealants	56
3.7	Performing “press” type connections for KAN-therm ultraPRESS fittings	57
3.8	Assembly of KAN-therm ultraPRESS fittings with diameters: 16, 20, 25, 26, 32 and 40 mm	62
3.9	Assembly of KAN-therm ultraPRESS fittings with diameters 50 and 63 mm	64
3.10	Minimum assembly distances	65
3.11	Threaded joints for PERTAL pipes with aluminum layer	65
4	Transport and storage	68

Table of contents

SYSTEM **KAN-therm PP**

1	General information	71
2	KAN-therm PP pipes	72
2.1	Physical properties of KAN-therm PP pipe material	73
2.2	Pipe marking, color	73
2.3	Dimension parameters of KAN-therm PP pipes	74
3	Fittings and other elements of the system	75
4	Scope of use	76
5	Technique of connecting KAN-therm PP installations – welded joints	78
5.1	Tools – preparation of the welder	79
5.2	Preparation of elements for welding	80
5.3	Welding technique	81
5.4	Fittings with metal threads and collars	82
6	Transport and storage	84

Table of contents

SYSTEM KAN-therm Steel / KAN-therm Inox

1	General information	89
2	System KAN-therm Steel	90
2.1	Pipes and fittings – characteristics	90
2.2	Pipe diameters, lengths, weight and capacity	90
2.3	Scope of use	91
3	System KAN-therm Inox	92
3.1	Pipes and fittings – characteristics	92
3.2	Pipe diameters, lengths, weight and capacity	92
3.3	Scope of use	93
4	Sealants – O-Rings	94
5	Durability, resistance to corrosion	95
5.1	Internal corrosion	96
5.2	External corrosion	98
6	Technique of Press joints	99
6.1	Tools	99
6.2	Preparation of pipes for pressing	106
6.3	Pipe bending	112
6.4	Threaded fittings, connecting with other KAN-therm systems	112
7	Flange connections	113
8	Ball valves of KAN-therm Steel and KAN-therm Inox systems	114
8.1	Service and maintenance	115
9	Operational notes	115
9.1	Equipotential bonding	115
10	Transport and storage	116

Table of contents

SYSTEM **KAN-therm** Copper

1	Modern connection technology	119
2	Durable connection technology	119
3	Applicability	120
4	Advantages	120
5	Assembly of connections	121
6	Tools	125
7	Tools – Safety	128
8	LBP function	128
9	Detailed information	128
10	Data on elongation and thermal conductivity	130
11	Recommendations for use	130
12	Threaded connections, connection to other KAN-therm systems	130
13	Flange connections	131
14	Transport and storage	132

Manifolds and cabinets for radiator heating and potable water systems

1	KAN-therm InoxFlow manifolds	135
2	Installation cabinets	136

Table of contents

Guidelines for installation design and assembly

1	Assembly of KAN-therm system at temperatures below 0 °C	141
2	Mounting KAN-therm system pipelines	143
2.1	Clamps and hangers	143
2.2	PP shifting points	144
2.3	PS fixed points	144
2.4	Passages through building partitions	147
2.5	Support spans	149
3	Compensation of thermal elongation of pipelines	151
3.1	Linear thermal elongation	151
3.2	Compensation of elongations	155
3.3	Compensators in KAN-therm system installations	158
4	Principles of laying KAN-therm installations	165
4.1	On-plaster installations – risers and horizontal pipelines	165
4.2	Conducting KAN-therm installations in structural partitions	166
4.3	Layout of KAN-therm installation	168
5	Connecting installation made of plastic pipes to the heat sources	171
5.1	Radiator connections	171
5.2	Union connectors for metal pipes	172
5.3	Water supply device connections	173
5.4	Requirements for fixing fittings in connection zones	173
5.5	Radiator connections	174
5.6	Tap connections	179
6	Compressed air installations in KAN-therm system	181
7	Rinsing, tightness tests and disinfection of KAN-therm installations	183
7.1	Water pressure test	183
7.2	Tightness tests with compressed air	184
8	KAN-therm system installation disinfection	186

Table of contents

Designing an installation

1	KAN-therm software supporting the design process	189
2	Hydraulic dimensioning of KAN-therm installations	190
2.1	Dimensioning water supply installations.....	190
2.2	Dimensioning central heating installations.....	192
3	Thermal insulation of KAN-therm installations	193

Information and safety tips

1.1	Intended use.....	195
1.2	Qualifications of participants in the construction process.....	196
1.3	General precautions.....	196

Check the availability of KAN-therm products in the current catalogue.

The photographs presenting the offered goods are for reference only. Actual colour and design details of the elements may differ from those presented in the photographs.

When the new catalogue is released, the information contained in the earlier version of the catalogue will be updated.

KAN Sp. z o.o. reserves the right to supplement, change or replace commercial and technical information at any time.

© KAN Sp. z o.o. copyrights All rights reserved. Text, images, graphics and their layout in KAN Sp. z o.o. publications are covered by copyrights.



**KAN-therm
MULTISYSTEM**

> 35 | years of experience
on the installation
market



KAN-therm

ultra**LINE**

**MANY POSSIBILITIES,
ONE CHOICE**

Install the **future**

SYSTEM **KAN-therm** ultraLINE

1	The idea behind the system	17
2	Advantages of KAN-therm ultraLINE system	18
3	Pipes in the KAN-therm ultraLINE system	18
3.1	Assortment of pipes in KAN-therm ultraLINE system.....	18
3.2	Construction and properties of KAN-therm ultraLINE system pipes.....	20
3.3	Operational parameters of KAN-therm ultraLINE system pipes.....	25
4	Fittings and sliding sleeves in KAN-therm ultraLINE system	26
4.1	Fittings in the KAN-therm ultraLINE system.....	26
4.2	Sliding sleeves in the KAN-therm ultraLINE system.....	27
4.3	Advantages of fittings and sliding sleeves design.....	28
5	Connections in the KAN-therm ultraLINE system	28
5.1	Connections with a sliding sleeve.....	28
5.2	Threaded connections in KAN-therm ultraLINE system.....	29
5.3	Threaded connections using fittings with nickel-plated pipes of the KAN-therm ultraLINE system.....	30
6	Contact with substances containing solvents, sealing the threads	31
7	Tools for installation of KAN-therm ultraLINE system	32
7.1	Configuration of tools for installation of KAN-therm ultraLINE system.....	32
7.2	Completing KAN-therm ultraLINE system tools.....	37
7.3	Advantages of KAN-therm ultraLINE system tools.....	37
7.4	Safety when using tools.....	37
8	Assembly of KAN-therm ultraLINE system connections	38
8.1	Assembly of connections with a sliding sleeve.....	38
8.2	Installation of universal threaded couplings and threaded connectors.....	40
8.3	Installation of universal eurocone adapters.....	41
8.4	Assembly of adapters for metal pipes.....	41
9	Transport and storage	42

SYSTEM **KAN-therm** ultraLINE

1 **The idea behind the system**

KAN-therm ultraLINE system is an innovative and the unique technical solution on the installation market, designed to perform both standard internal heating and drinking water systems, as well as specialized piping installations such as compressed air.

Its unique design and the ability of flexible configuration of a complete end solution give great convenience for the installers and designers.

Flexibility of KAN-therm ultraLINE system configuration consists of the possibility of using various types of pipes with the same design of fittings:

- The group of KAN-therm ultraLINE pipes with aluminum layer – in the whole diameter range of 14–32 mm, it includes PERTAL² pipes, brass or plastic ultraLINE fittings (PPSU) and plastic sleeves (PVDF),
- The group of KAN-therm ultraLINE pipes with EVOH layer – it includes polyethylene PEXC and PERT² pipes in the diameters of 14–20 mm, ultraLINE fittings made of brass or plastic (PPSU) and plastic sleeves (PVDF).

The O-Ringless construction of the fittings and the sliding sleeve technique guarantee high resistance of the system to assembly errors and ageing of materials during the system operation. Owing to this, the system is characterized by high safety of assembly and operation as well as high durability of the performed system.

2 Advantages of KAN-therm ultraLINE system

Innovative design of KAN-therm ultraLINE system fittings and the sliding sleeve technique mean:

- Possibility of any configuration of the system according to own preferences: PEXC and PERT² pipes as well as PERTAL² pipes can be used with the same connectors and fittings.
- Universal application of the system,
- Quick, simple and convenient installation, even in hard to access places,
- Possibility of using dedicated tools and press drives widely available on the market for „Press“ systems*,
(* when using special adapter)
- Permanent and secure connection without additional seals – O-Ringless construction of the fittings,
- Recess mounting possible in the construction of building partitions,
- Significant reduction of the diameter narrowing due to pipe expanding process,
- High resistance to corrosion,
- Up to 25% increased system hydraulics compared to the competitors**,
(**applies to diameters 25 and 32 mm assembled in the sliding sleeve technique)
- Significantly increased comfort of installation of large diameters and no need for dense fastening of the pipeline due to the multilayer structure of the pipes,
- The most flexible pipe on the installation market among the O-Ringless systems,
- Technical solution based on many years of experience in the field of systems for the construction of heating and drinking water systems.

3 Pipes in the KAN-therm ultraLINE system

KAN-therm ultraLINE system offers the possibility of flexible configuration of the final technical solution by the system designer, contractor or investor, which is rare on the market. The selection of appropriate system may be dictated not only by the preferences of people participating in the investment process, but also by the specifics of the investment, e.g. the need for surface mounting in religious or historic buildings, where pipes with aluminum layer will have much better performance properties.

3.1 Assortment of pipes in KAN-therm ultraLINE system

Types and diameters of pipes

KAN-therm ultraLINE pipes with EVOH layer		KAN-therm ultraLINE pipes with aluminum layer
PEXC 14 × 2	PERT ² 14 × 2	PERTAL ² 14 × 2
PEXC 16 × 2,2	PERT ² 16 × 2,2	PERTAL ² 16 × 2,2
PEXC 20 × 2,8	PERT ² 20 × 2,8	PERTAL ² 20 × 2,8
		PERTAL ² 25 × 2,5
		PERTAL ² 32 × 3

In the diameter range of 14–20 mm, KAN-therm ultraLINE system uses different pipe designs, with EVOH layer and with aluminum layer. In 25-32 mm diameter range only the pipes with aluminium layer are available and supplement the ultraLINE offer in the bigger diameters.

Pipes with aluminum layer include:

- pipe PERTAL² – 14 × 2,
- pipe PERTAL² – 16 × 2,2,
- pipe PERTAL² – 20 × 2,8,
- pipe PERTAL² – 25 × 2,5,
- pipe PERTAL² – 32 × 3.

Pipes PERTAL² include ultrasonic butt-welded elastic aluminum layer in the design. Thanks to that the pipes are protected against oxygen diffusion inside of the installation. The aluminium layer also limits the excessive elongation of the pipeline under the influence of temperature.

Due to the limited thermal elongation PERTAL² pipes are perfect for surface installations.

Pipes with EVOH layer include:

- pipe PERT² or PEXC – 14 × 2,
- pipe PERT² or PEXC – 16 × 2,2,
- pipe PERT² or PEXC – 20 × 2,8.

The designs of PEXC and PERT² pipes include EVOH layer that protects the installation against the oxygen diffusion inside of it.

PEXC and PERT² pipes are used mainly for housing distribution in recess-mounted installations (distribution in floor screed or covered wall furrows) perfectly use the phenomenon of shape memory. This feature ensures a very good protection of system against accidental crushing of the pipe under the impact of high local mechanical load and thus, the creation of narrowing or its complete closing. This is a very practical feature for large investments, where many assembly brigades work simultaneously.

PERTAL² pipes included in the system in the diameter range of 25–32 mm use their plastic properties exquisitely. Pipes with such diameters are mainly used for the installation of main supply pipelines and possible risers. Lack of memory of the PERTAL² pipes shape and thus, no phenomenon of the so-called pipe tensioning gives great freedom and comfort in installing large diameter pipelines. The consequence of using this type of pipes may be a reduction in the number of additional profiling and anchoring elements for the pipeline.

Both PEXC or PERT² pipes and PERTAL² pipes are applicable with the KAN-therm ultraLINE system plastic PPSU or brass fittings and plastic sliding sleeves.



3.2 Construction and properties of KAN-therm ultraLINE system pipes

Construction and properties of PEXC and PERT² pipes

All PEXC and PERT² pipes (diameters 14–20 mm) are made in a five-layer structure. Both types of pipes have a barrier (EVOH layer) that prevents penetration (diffusion) of oxygen through the walls of pipes from the environment to the interior of the system. This location of the EVOH anti-diffusion layer protects it against possible damage during the assembly.

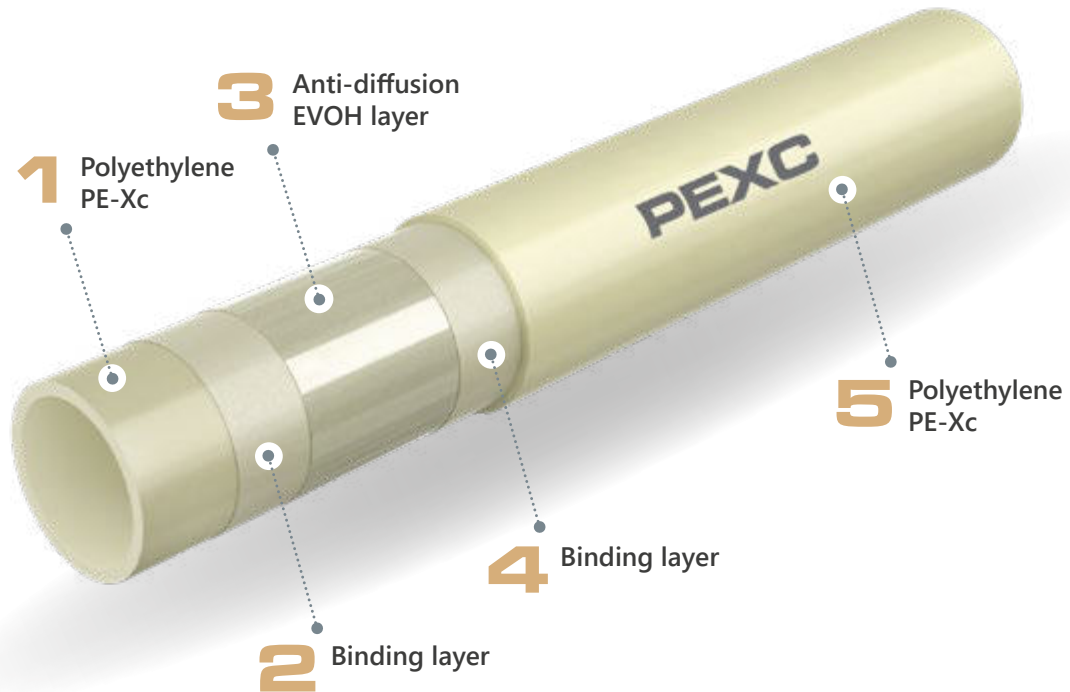

Cross-section of PEXC pipe with anti-diffusion coating

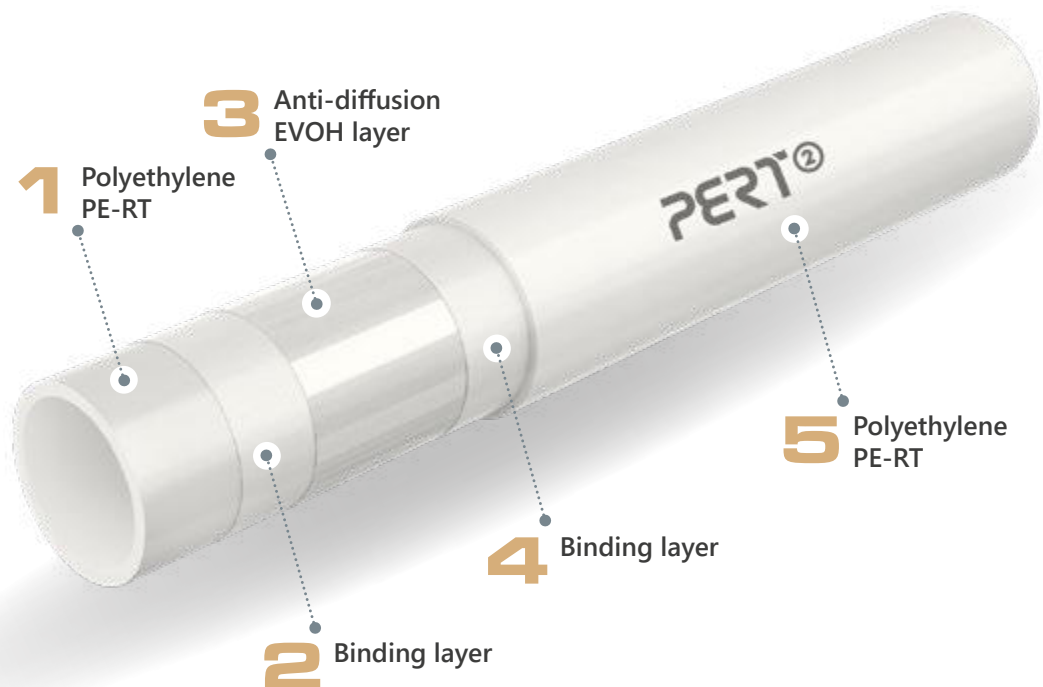

Cross-section of PERT² pipe with anti-diffusion coating

The EVOH anti-diffusion layer (ethyl vinyl alcohol) meets the requirements of DIN 4726.

PEXC pipes

PEXC pipes are produced of a high-density polyethylene and are subjected to cross-linking with an electron beam („c” method – a physical method, without using chemical agents). Therefore, in the product range of the catalogue they will be described as PEXC pipes.

PEXC pipes are equipped with an EVOH anti-diffusion layer, therefore they can be used in both heating and drinking water systems.

Pipes in the entire diameter range, i.e. $\text{Ø}14 \times 2$, $\text{Ø}16 \times 2,2$, $\text{Ø}20 \times 2,8$, are available in two variants:

- without thermal insulation,
- with 6 mm thick thermal insulation, in grey color.



Pipe color: ivory.

The pipes are supplied in coils in lengths that depend on the pipe diameter and its version, i.e. with or without thermal insulation.

Dimensional specification of PEXC pipes

DN	De x t	t	Di	Size S series	Unit weight	Capacity	Packing
	[mm x mm]	[mm]	[mm]		[kg/m]	[l/m]	[m]
14	14 x 2,0	2,0	10,0	3,0	0,085	0,079	200
16	16 x 2,2	2,2	11,6	3,0	0,102	0,106	200
20	20 x 2,8	2,8	14,4	3,0	0,157	0,163	100

PERT² pipes

PERT² pipes are made of a high thermal resistance polyethylene PE-RT type II.

PERT² pipes are equipped with an EVOH anti-diffusion layer, therefore they can be used in both heating and drinking water systems.

Pipes in the entire series of diameter types, i.e. Ø14 × 2, Ø16 × 2,2, Ø20 × 2,8, are available in several variants:

- without thermal insulation,
- with 6 mm thick thermal insulation, in grey, red and blue color.



Pipe color: neutral.

The pipes are supplied in coils in lengths that depend on the pipe diameter and its version, i.e. with or without thermal insulation.

Dimensional specification of PERT² pipes

DN	De × t	t	Di	Size S series	Unit weight	Capacity	Packing
	[mm × mm]	[mm]	[mm]		[kg/m]	[l/m]	[m]
14	14 × 2,0	2,0	10,0	3,0	0,085	0,079	200
16	16 × 2,2	2,2	11,6	3,0	0,100	0,106	200
20	20 × 2,8	2,8	14,4	3,0	0,155	0,163	100

Physical properties of PEXC and PERT² pipes

Property	Symbol	Unit	PEXC	PERT ²
Thermal expansion coefficient	α	mm/m × K	0,178	0,18
Heat conductivity	λ	W/m × K	0,35	0,41
Minimal bend radius	R _{min}	mm	5 × De	5 × De
Internal wall roughness	k	mm	0,007	0,007

Pipe marking - based on PERT² pipes

All pipes are marked with permanent description placed continuously every 1 m i. a. the following markings:

Marking type	Example of marking
Manufacturer's name and/or trademark	KAN-therm ultraLINE PERT ²
Nominal outer diameter x wall thickness	20 x 2,8
Pipe structure (material)	PE-RT
Product code	2529198002
Number of standard or Technical Certificate	EN ISO 21003
Application class/-es with design pressure	Class 2/10 bar, Class 5/10 bar
Anti-diffusion marking	Sauerstoffdicht nach DIN 4726
Date of production	18.08.19
Other manufacturer's markings, e.g. running metre, batch number	045 m



Note – other, additional markings, e.g. numbers of certificates (e.g. DVGW), may also be inscribed on the pipe.

Construction and properties of PERTAL² pipes

PERTAL² pipes (diameters 14–32 mm) comprise of the following layers: an inner layer (core pipe) of PE-RT type II polyethylene with improved thermal resistance, a middle layer of an butt-welded aluminium as well as an outer layer that is also made of PE-RT type II polyethylene. An adhesive binding layer is applied between the aluminium and plastic layers.

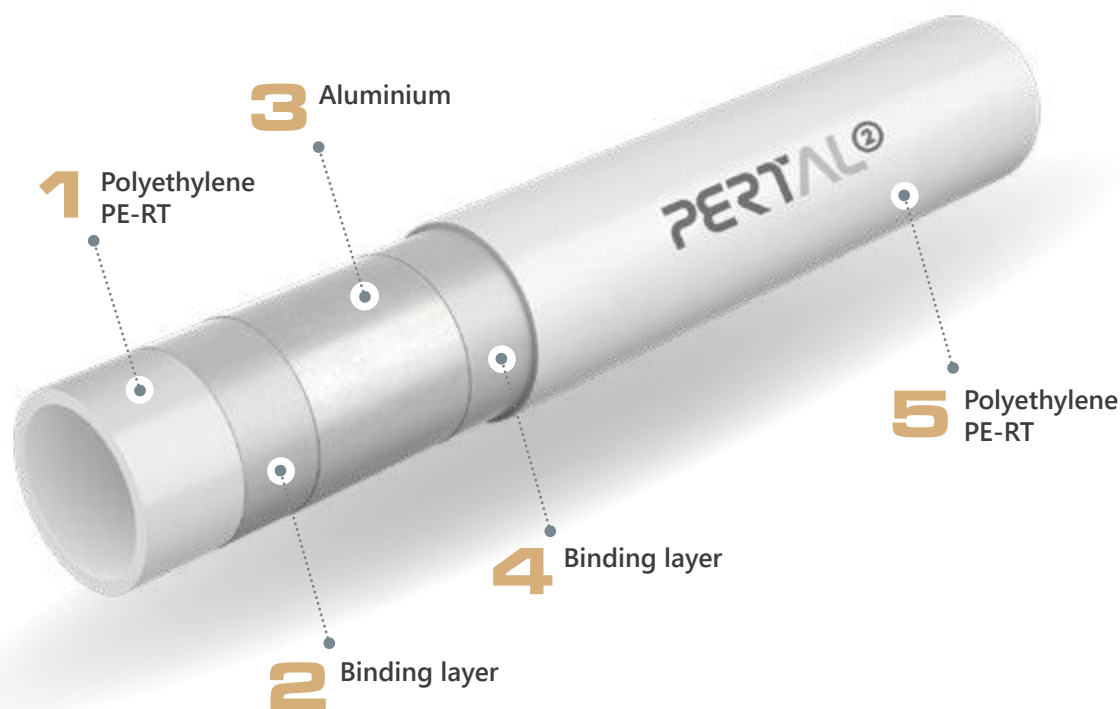

PERTAL² pipe cross-section

The aluminium layer serves as a anti-diffusion barrier and lowers the thermal pipe elongation index 8 times, as compared to polyethylene pipes with EVOH layer. Owing to the butt welding of the Al strip, the thickness of individual layers of the pipe wall is constant around the entire circumference.

Pipes in the entire series of diameter types, i.e. $\text{Ø}14 \times 2$, $\text{Ø}16 \times 2,2$, $\text{Ø}20 \times 2,8$, $25 \times 2,5$, 32×3 , are available in several variants:

- without thermal insulation,
- with 6 mm thick thermal insulation, in grey, red and blue color.

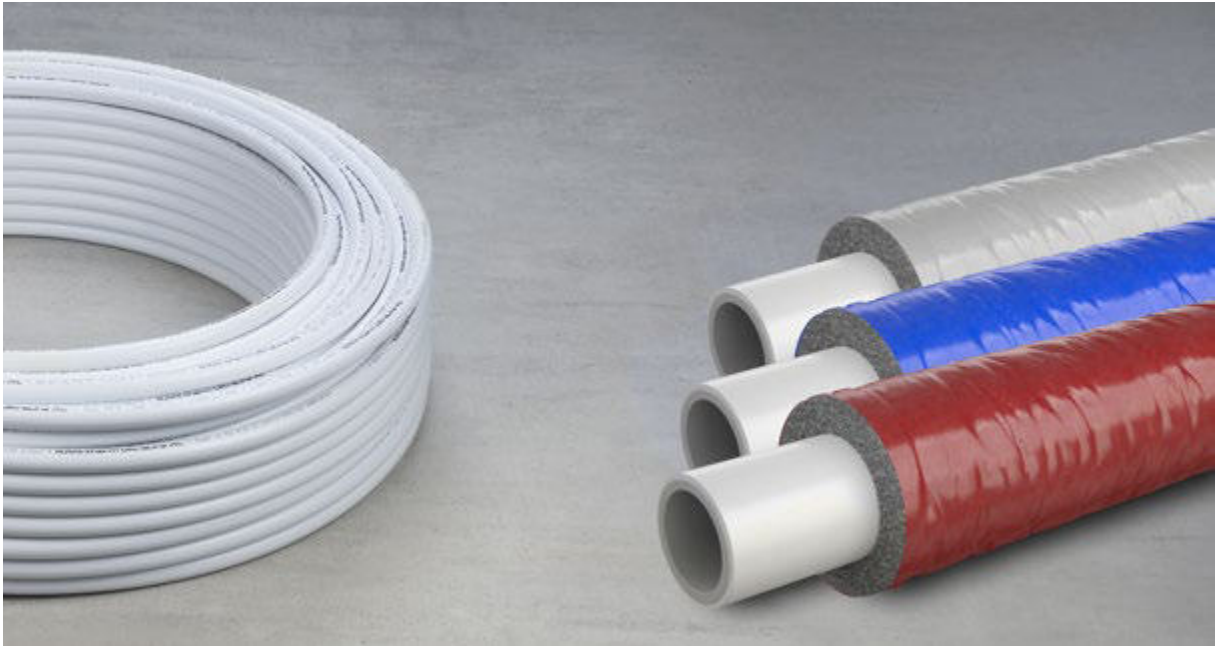

Pipe color: white.

Pipes are supplied in coils in lengths depending on the diameter of the pipe and its version, i.e. with or without thermal insulation.

Pipes without thermal insulation are also available in 5 m bars.

Dimensional specification of PERTAL² pipes

DN	De × t	t	Di	Size S series	Unit weight	Capacity	Packing
	[mm × mm]	[mm]	[mm]		[kg/m]	[l/m]	[m]
14	14 × 2,0	2,0	10,0	3,0	0,097	0,079	200
16	16 × 2,2	2,2	11,6	3,0	0,114	0,106	200
20	20 × 2,8	2,8	14,4	3,0	0,180	0,163	100
25	25 × 2,5	2,5	20,0	4,5	0,239	0,314	50
32	32 × 3,0	3,0	26,0	4,8	0,365	0,531	50

Physical properties of PERTAL² pipes

Property	Symbol	Unit	Value
Thermal expansion coefficient	α	mm/m × K	0,025
Heat conductivity	λ	W/m × K	0,43
Minimal bend radius	R_{\min}	mm	$3,5 \times De$
Internal wall roughness	k	mm	0,007

Pipe marking - based on PERTAL² pipes

All pipes are marked with permanent descriptions placed continuously every 1 m, containing i. a. the following markings:

Marking description	Example of marking
Manufacturer's name and/or trademark	KAN-therm ultraLINE PERTAL ²
Nominal outer diameter x wall thickness	16 x 2,2
Pipe structure (material)	PE-RT/Al/PE-RT
Product code	2529334003
Number of standard or Technical Certificate	KIWA, KOMO, DVGW
Application class/-es with design pressure	Class 2/10 bar, Class 5/10 bar
Date of production	18.08.19
Other manufacturer's markings, e.g. running metre, batch number	045 m



Note – other, additional markings, e.g. numbers of certificates, may also be inscribed on the pipe.

3.3 Operational parameters of KAN-therm ultraLINE system pipes

PERT², PERTAL² and PEXC pipes in accordance with PN-EN ISO 21003–2 standard, may operate at below mentioned parameters:

Operating parameters and scope of use for PEXC, PERT² and PERTAL² pipes

Type of installation and application class (acc. ISO 10508)	Top/Tmax [°C]	DN	Operating pressure Pop [bar]			Connection type	
			PEXC	PERT ²	PERTAL ²	sliding sleeve	threaded
Cold tap water	20	14	10	10	10	+	+
		16	10	10	10	+	+
		20	10	10	10	+	+
		25			10	+	-
		32			10	+	-
Hot tap water [class 1]	60/80	14	10	10	10	+	+
		16	10	10	10	+	+
		20	10	10	10	+	+
		25			10	+	-
		32			10	+	-
Hot tap water [class 2]	70/80	14	10	10	10	+	+
		16	10	10	10	+	+
		20	10	10	10	+	+
		25			10	+	-
		32			10	+	-
Low-temperature heating and radiant heating [class 4]	60/70	14	10	10	10	+	+
		16	10	10	10	+	+
		20	10	10	10	+	+
		25			10	+	-
		32			10	+	-
Radiator heating [class 5]	80/90	14	10	10	10	+	+
		16	10	10	10	+	+
		20	10	10	10	+	+
		25			10	+	-
		32			10	+	-

Operating temperature Top in individual classes should be treated as the design temperature, maximum temperature T_{max} as the temperature before exceeding, in which the systems should be secured.

4 Fittings and sliding sleeves in KAN-therm ultraLINE system

Apart from the offer of various types of pipes, the complete KAN-therm ultraLINE system also includes fittings and sliding sleeves.

Fittings are available in plastic PPSU and brass. Sliding sleeves are produced and offered only in the plastic PVDF version.



4.1 Fittings in the KAN-therm ultraLINE system

KAN-therm ultraLINE system fittings can be connected with the PEXC, PERT² and PERTAL² pipes.

In all cases the fittings use an O-Ringless design, thus ensuring easy and safe assembly and long-term, trouble-free operation of the installation.



1. KAN-therm ultraLINE system fitting.
2. Plastic (PVDF) sliding sleeve of the KAN-therm ultraLINE system.
3. PEXC, PERT² or PERTAL² pipe.

KAN-therm ultraLINE system offer provides a whole range of fittings necessary to perform even the most complex piping installations:

- Couplings and reducers made of plastic PPSU and brass,
- Steel / ultraLINE transition connectors made of brass,
- PPSU plastic and brass elbows,
- Equal and reduction tees made of plastic PPSU and brass,
- ultraLINE brass plugs,
- Brass fittings with threads,
- Brass elbows and tees with threads,
- Tap connectors with various lengths in brass design,
- Brass elbows and tees with nickel-plated pipes.

4.2 Sliding sleeves in the KAN-therm ultraLINE system

Sliding sleeves of KAN-therm ultraLINE system are one of the most important elements responsible for connecting and sealing the pipe with the fitting. The sleeves are produced only of high quality PVDF.



As in the case of the fittings, depending on the selected pipe configuration, the sliding sleeves can be used with pipes with EVOH layer (PEXC and PERT²) and pipes with aluminum layer (PERTAL²).

For proper tight and mechanically strong connections only KAN-therm ultraLINE system sleeves must be used. It is forbidden to use sleeves other than the recommended ones or products of foreign origin.

Each original sliding sleeve of the KAN-therm ultraLINE system has the KAN marking embossed and the diameter on the outer surface for which it is intended.

4.3 Advantages of fittings and sliding sleeves design

Fittings and sliding sleeves in the KAN-therm ultraLINE system bring:

- wide range of fittings and threaded connections,
- versatility of use, allowing the use of brass and plastic elements for virtually every type of installation,
- wide range of plastic components (PPSU), guaranteeing the possibility of price optimization of the complete investment and securing the system against negative effects of water with an unfavourable chemical composition,
- universal design of threaded couplings ensuring safe and tight connection with various types of pipes – with EVOH layer (PEXC and PERT²) and with aluminum layer (PERTAL²).
- design of elements in diameters 25 and 32 mm with increased internal cross-section, thanks to which the hydraulics is significantly increased and the so-called hydraulic optimization of the designed systems is enabled,
- elements of acoustic protection of the system available in the standard offer,
- aesthetic look of the fittings and bright color of PPSU plastic design that significantly increases the visibility of the element in dark rooms,
- symmetrical design of the sliding sleeves that minimizes the risk of mistakes and significantly increases convenience during assembly.

5 Connections in the KAN-therm ultraLINE system

5.1 Connections with a sliding sleeve



KAN-therm ultraLINE system fittings are universal and can be used with PEXC, PERT² (pipes with EVOH layer) pipes and PERTAL² pipes (pipes with aluminium layer).

Fittings have specially shaped connector stubs (without additional seals), which are inserted into the previously expanded end of the pipe and then a plastic sleeve is slid onto the connection.

The pipe is crimped circumferentially on the coupling stub in the entire contact plane. Such connection allows conducting the installation in structural partitions (in flooring screeds coats and under layers of plaster) without any limitations.

Special features of the connection with a sliding sleeve in KAN-therm ultraLINE system

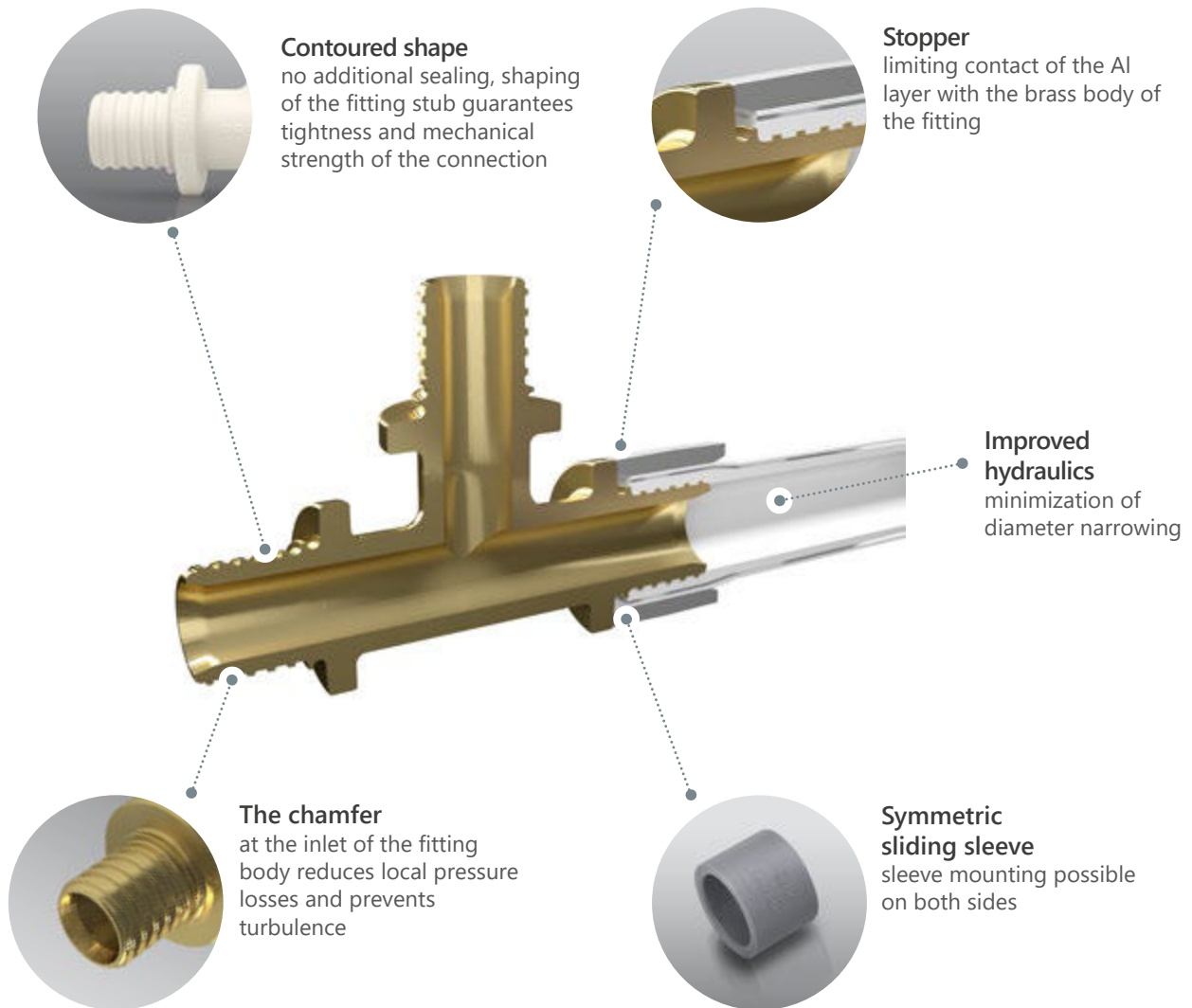

5.2 Threaded connections in KAN-therm ultraLINE system

To connect KAN-therm ultraLINE system pipes, in addition to connections with a sliding sleeve, standard threaded connections with a wrench can be used.

Two main types of connectors are available for these couplings:

- Universal threaded couplings with male and female threads or so-called couplings, available in diameters 14–20 mm (brass threaded connector, brass female threaded connector) and 14–25 mm (brass male threaded connector). Threaded fittings at the pipe connection side do not require the use of additional seals – tightness is guaranteed by the appropriate construction of the coupling stub on which the pipe is mounted. From the thread side (internal or external) an additional sealing in the form of tow should be used. Threaded connectors, due to the specificity of the fitting and its design, do not require additional sealing. These fittings should be located in easily available places.



- Universal eurocone adapters available in the diameter range of 14–20 mm. Real advantage of those couplings is their automatic sealing after fitting. Connections of this kind are self-sealing and need no additional seal, such as Teflon tape or tow. These elements should be located in easily available places.



As the name suggests both universal threaded couplings and universal eurocone adapters have structure which allows the simultaneous installation of PEXC and PERT² (pipes with EVOH layer) pipes and PERTAL² pipes (pipes with aluminium layer).

Thanks to the universal structure of couplings and eurocone adapters, duplicating the fitting offer is avoided, which translates into more flexible and convenient assembly, as well as saving space for storing elements.

! **Note! PERTAL² (pipes with aluminium layer) require calibration and chamfering for threaded connectors and pipe unions!**

5.3 Threaded connections using fittings with nickel-plated pipes of the KAN-therm ultraLINE system

Combined fittings with nickel-plated copper pipes also provide a complete system solution. The elements are very often used for aesthetic connection of radiators or other wall mounted equipment. Depending on the needs, the system offer provides the possibility of using fittings such as single elbows, double elbows as well as equal and reduction tees.



The elements can also be distinguished depending on the length of the nickel-plated copper pipe. 300 mm or 750 mm lengths are available.

Elbows and tees with a nickel-plated pipe should be connected with radiator valves and directly with the VK-type radiators by means of fittings for connecting nickel-plated Ø15 mm pipes.

All joints of this kind are self-sealing and no additional sealing is needed.

6 Contact with substances containing solvents, sealing the threads

- Secure the plastic (PPSU) elements of KAN-therm system against contact with: solvents or solvent-containing materials, such as paints, aerosols, fitting foams, adhesives, etc. Under unfavourable circumstances, these substances may damage plastic parts.
- Make sure that the connection sealants, cleaners or insulation of KAN-therm system components, do not contain compounds that cause stress cracks: ammonia, ammonia retaining compounds, solvents, aromatic or chlorinated hydrocarbons (e.g., ketones and ethers). Do not use fitting foams based on methacrylate, isocyanate and acrylate when in contact with plastic (PPSU) elements of KAN-therm system.
- Secure pipes and plastic (PPSU) fittings against direct contact with: adhesive tapes and insulation adhesives. Adhesive tapes should only be used on the outer surface of thermal insulation.
- It is advised to seal threaded connections with such an amount of hemp, that leaves the thread tops not covered. Using too much hemp may lead to thread damage. By winding hemp just after the first thread ridge you can avoid skew screwing and damaging the thread.
- When making screwed (threaded) connections, precautions should be taken in the form of: using the right amount of sealing material (tow) and correct tightening torque. In unfavorable situations, a threaded connection made with too much sealant and/or overtightened can lead to critical mechanical stresses in the connector material and damage to the product.
- Minimise the risk of prolonged dampness and condensation on the surface of pipes and fittings.
- Do not use brass components of the KAN-therm system in environments where ammonia of biological origin is present or may be present, particularly in livestock facilities.
- Pay attention to the connection of different types of threads. In unfavorable cases, there may be a collision of the outlines of the female and male threads, which can lead to building up excessive mechanical stress in the fitting material and consequent damage.



NOTE!!!

Do not use chemical sealants or adhesives.

7 Tools for installation of KAN-therm ultraLINE system

All elements of KAN-therm ultraLINE system must be combined using specially designated tools. These tools are included in the system offer.

7.1 Configuration of tools for installation of KAN-therm ultraLINE system



Battery tools set

The photo above shows an example set based on a battery sliding sleeve tool and an battery expander. These are the latest generation tools, which greatly accelerate the assembly process. These tools are dedicated to KAN-therm ultraLINE system and specially developed for the needs of optimal and safe assembly of connections. The light weight and compact design as well as the built-in flashlight significantly increase the comfort and safety of working at the construction site. The battery indicator allows constant monitoring and prior preparation of tools, so that users can properly organize and save their work time.

LED Identification is a function of electronic diagnostics of tools condition and the assembly process itself, through a special LED, device informs the user about the possible need of tool service. Modern 10,8 V technology significantly accelerates battery charging time.

For customers basing on classic tool solutions, we have also prepared improved versions of hand operated tools that allow the correct assembly of the system.

The hand operated sliding sleeve tool and expander are a simple and reliable constructions, made of the highest quality materials, guaranteeing their long lifespan.



Hand tools set

Very small dimensions of the hand operated sliding sleeve tool allow performing easy connection of the ultraLINE elements even in the most difficult to reach places. No need to charge the battery is a big plus in case of the absence of access to the electrical grid. Hand operated and electric tools use the same complementary accessories, i.e. sliding sleeve forks and expanding heads.

Pipe cutters

For pipes cutting, use dedicated, good-quality pipe cutters, guaranteeing correct cutting. Make sure that the cutting blade is sharp and free from damages which can deteriorate the quality of the cut and at the same time affect the quality of the connection made (especially important when assembling connections at temperatures below 0 °C).



Expanders

Expanders are used to perform the process of expanding the pipe end (flaring of the pipe end diameter). This process is possible thanks to special expanding heads working with the flaring tool.



The expanding heads have a different design, depending on the type of pipe used. Make sure that the appropriate expanding head is used in the process of flaring the pipe end.

**NOTE!**

The selection of a proper expanding head for a given type of pipe is very important for the correctness of tight and durable connection of KAN-therm ultraLINE system.

KAN-therm ultraLINE - pipes with EVOH layer			KAN-therm ultraLINE - pipes with aluminium layer		
Pipe type	Diameter	Expanding head type	Pipe type	Diameter	Expanding head type
PEXC, PERT ²	14 × 2	ultraLINE PE 14	PERTAL ²	14 × 2	ultraLINE AL 14
	16 × 2,2	ultraLINE PE 16		16 × 2,2	ultraLINE AL 16
	20 × 2,8	ultraLINE PE 20		20 × 2,8	ultraLINE AL 20
		25 × 2,5		ultraLINE AL 25	
				32 × 3	ultraLINE AL 32

Sliding sleeve tools

Sliding sleeve tools cooperate with sets of sliding sleeve forks. Two sliding sleeve forks are available for each diameter, i.e. from 14 × 2 to 32 × 3. To make a connection on a given diameter, equip the sliding sleeve tool with a suitable set of forks.



An additional feature of KAN-therm ultraLINE system is the possibility of its assembly using standard electric drives used for radial pressing (e.g. KAN-therm ultraPRESS system). This option is implemented by using a special KAN-therm ultraLINE system adapter in combination with a "Press" tool.



Sliding sleeve forks

The design of KAN-therm ultraLINE system sliding sleeve forks ensures a very wide angle of access to the fitting, which significantly increases the comfort of assembling the system in hard to reach places.



The possibility of approaching with the forks to the fitting at an angle from 0° to even 270° guarantees the greatest convenience and flexibility of assembly among the competitive solutions.

7.2 Completing KAN-therm ultraLINE system tools

- **Set I:** tool case, expander, manual chain sliding sleeve tool, pipe cutters and grease,
- **Set II:** tool case, expander, adapter for „Press“ type tools, pipe cutters and grease,
- **Set III:** tool case, expander, battery sliding sleeve tool with spare battery, charger, pipe cutters and grease,
- **Set IV:** tool case, battery expander, battery sliding sleeve tool, spare battery, charger, pipe cutters and grease,
- **Set V:** tool case, expander and grease,
- **Set VI:** tool case, battery expander, battery sliding sleeve tool, spare battery, charger, pipe cutter, expanding heads for PERTAL² pipes 16-25, crimping fork sets 16-25, pipe calibrator and grease,
- **Set VII:** tool case, battery expander, battery sliding sleeve tool, spare battery, charger, pipe cutter, expanding heads for PEXC and PERT² pipes 16-20, expanding head for PERTAL² pipes 25, sliding sleeve fork sets 16-25 and grease.



Note! Expanding heads and forks must be completed separately depending on the user preferences.

7.3 Advantages of KAN-therm ultraLINE system tools

- possibility of using manual chain tools and drives for „Press“ connections by the use of the KAN-therm ultraLINE system adapter,
- sliding sleeve forks dedicated to specific diameters, without the need to differentiate in terms of material, fittings and sliding sleeves,
- mechanical bumper in the construction of sliding sleeve forks protects fittings and sleeves against possible damage due to excessive force by means of electric and electro-hydraulic drives,
- wide angle of access to the fitting for sliding sleeve forks further increases the convenience of mounting, especially in hard to reach places,
- quick and uncomplicated assembly – simple rules,
- safe and fault-free assembly process,
- new quality of tools – light and handy designs due to the use of high-quality materials,
- plastic cases equipped with a special interconnecting system guarantee a convenient manner of transporting tool sets.

7.4 Safety when using tools

All tools must be used according to their dedicated purpose and the manufacturer's instruction manual. Use for other purposes or in other areas is considered to be inconsistent with the intended use.

Intended use also requires compliance with the instructions, conditions of inspection and maintenance and relevant safety regulations in their current version.

All works done with tools, which do not meet the application compatible with its intended purpose may result in damage of tools, accessories and pipes. The consequence may be the leak and/or damage of connections.

8 Assembly of KAN-therm ultraLINE system connections

To perform connections in KAN-therm ultraLINE system, use original KAN-therm tools only. Tools are available as individual components or in complete sets. Standard assembly of the system should be carried out at an ambient temperature above 0 °C.

If it is necessary to carry out assembly in subzero temperatures, please contact the KAN Technical Support Department for additional information.

Before starting work:

- read the instructions for use of the tools which are included in the packaging or box with a set of tools,
- check technical condition of tools with which the connections are planned to be made.

8.1 Assembly of connections with a sliding sleeve

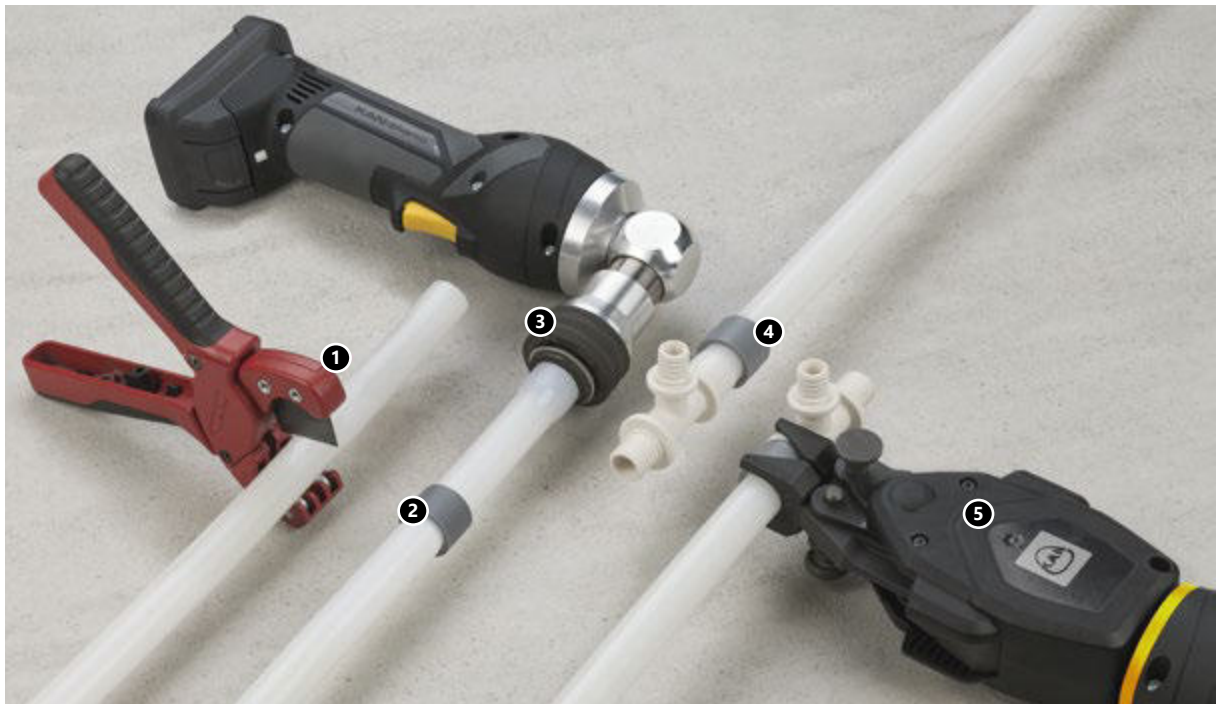

1. The selected KAN-therm ultraLINE pipe should be cut perpendicularly to the axis to the required length by means of pipe cutters. It is not allowed to use tools or scissors which are faulty (blunt or chipped).
2. Put the sleeve onto the pipe. Symmetric structure allows both-side installation.
3. Pipe expander should be equipped with a head suitable for the type of the pipe and its diameter. Insert the expanding head fully into the pipe until it stops, axially into the pipe end. Expansion of the pipe should be carried out in two phases:
I – initial full expansion of the pipe, in full range of the tool stroke, turn the expander by 30° after expansion,
II - final expansion of the pipe, in full range of the tool stroke.
4. Directly (!) after expansion, insert the fitting into the pipe to the last protrusion on the fitting stub (do not push the pipe up to the fitting flange!). Do not use lubricants.
5. Detailed guidelines for sliding the sleeves are mentioned in point 5a - 8.



If cracks appear on the expanded section of pipe or the pipe has not been expanded evenly on the entire circumference, cut off the damaged piece and carry out the expansion again. If the pipe is excessively stretched, its material may build up during the connecting. In such a case, finish sliding the sleeve onto the pipe in front of fittings flange (keep a distance of max. 2 mm from the fitting flange). Expanding of pipes in temperatures below 0 °C must be done in modified method - see chapter „KAN-therm system assembly in temperatures below 0 °C“.



5a. Sliding sleeve machine should be equipped with special forks. A separate set of forks is intended for each diameter. The forks are equipped with special bumpers protecting the fitting and the sleeve against damage due to excessive crimping force.

5b. Slide the sleeve using manual chain tool. The fittings may be grabbed only by their collars. It is forbidden to slide on two sleeves at the same time.



5c. It is possible to slide a sleeve on with the use of electric drives, typical for "Press" connections. The condition to use this type of tools for sliding the sleeve is the use of a special adapter provided by KAN-therm ultraLINE system. When sliding the sleeve onto the fitting, the assembly process should be observed – after the sleeve is pushed up to the fitting flange, the sliding process should be stopped.

6. The connection is ready for the pressure testing.

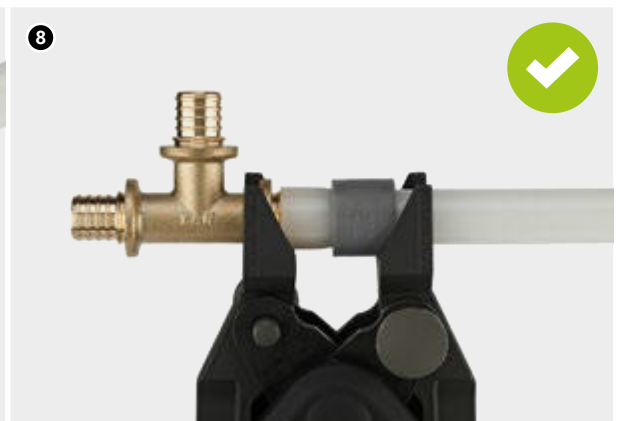
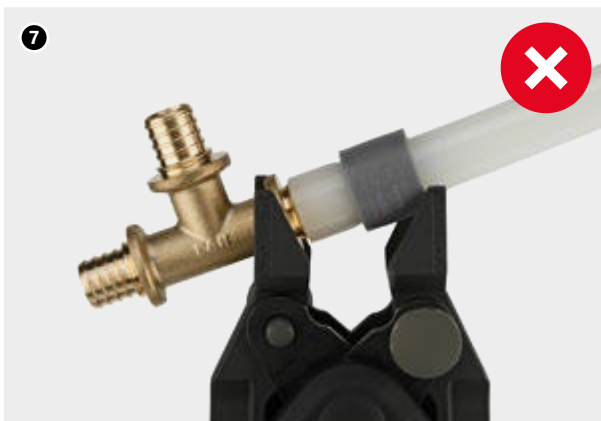

7 – 8. Pay attention to correct position of the fittings in the forks of the tools. In the event of non-compliance with this rule, the fitting and the components of the connection may be overloaded.



NOTE!

When making connections of the KAN-therm ultraLINE system, special attention should be paid to the correct position of the fitting in the forks of the tool. Always insert the forks to their full depth and at right angle to the connection being made. Do not move the sliding sleeve tool sideways while making connections.

8.2 Installation of universal threaded couplings and threaded connectors

Fittings of this type are made of brass. The connections include a coupling body with a stub pipe and an O-Ring seal, a compression brass ring and a threaded compression nut are applied.

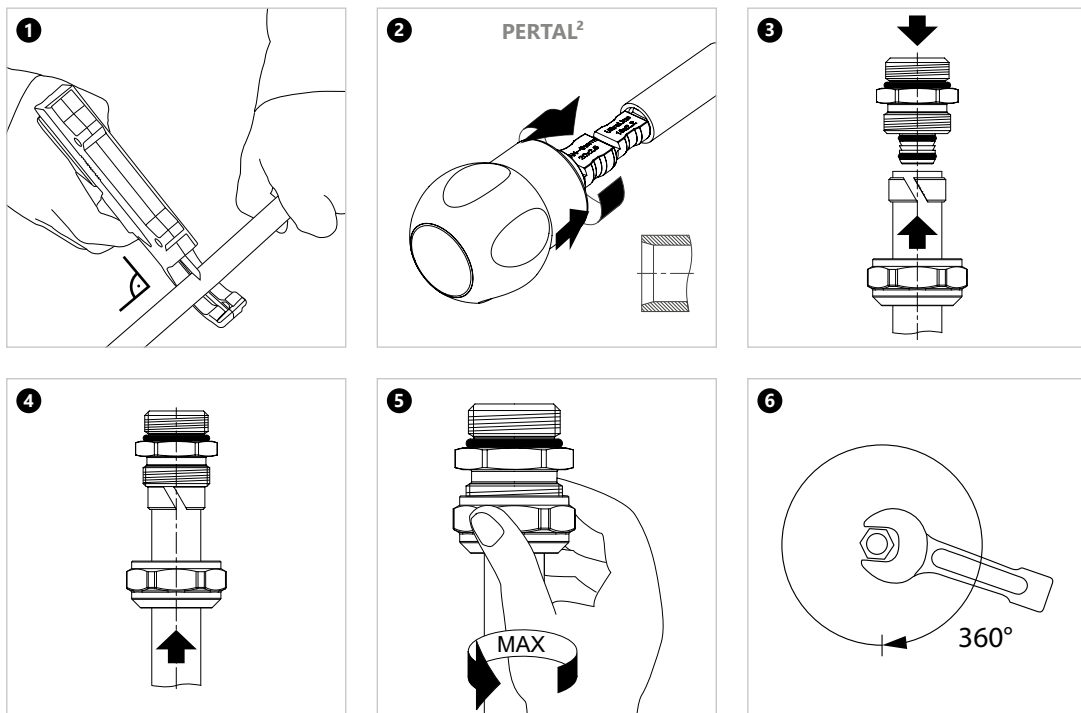

1. The selected KAN-therm ultraLINE pipe should be cut perpendicularly to the axis to the required length by means of pipe cutters. It is not allowed to use tools or scissors which are faulty (blunt or chipped).
2. Calibrate the pipe and chamfer (only PERTAL² pipes) its inner edges with a calibrator but not deeper than to the aluminium layer. Fit onto a pipe the screwed joint nut with the compression ring (or a connection nut).
3. Screw the connector body into the fitting with sealing the thread utilizing tow or Teflon tape. Put a clamping nut on the pipe and then place a compression ring at the end of the pipe, noting that it should be located at a distance from the edge of the pipe between 0,5 to 1 mm.
4. Insert the pipe fully over the coupling stub pipe (do not use any lubricants, do not make any twisting movement of the fitting in relation to the pipe).
5. As much as possible, tighten the nut over the pipe and the compression ring by hand, without using any additional tools – hand tightening only.
6. Tighten the nut over the pipe and compression ring with a spanner. When tightening, just one full 360° rotation is needed to obtain proper seal.

The connection can be considered as dismantable provided that after removing the coupling stub from the pipe, the worn end of the pipe will be cut off before making a new connection.

8.3 Installation of universal eurocone adapters

It is a variation of threaded connections, in which the basic element is a clamping cone with an O-Ring seal which does not require additional sealing methods. They can be treated as detachable, provided that the pipe is not removed from the fitting.

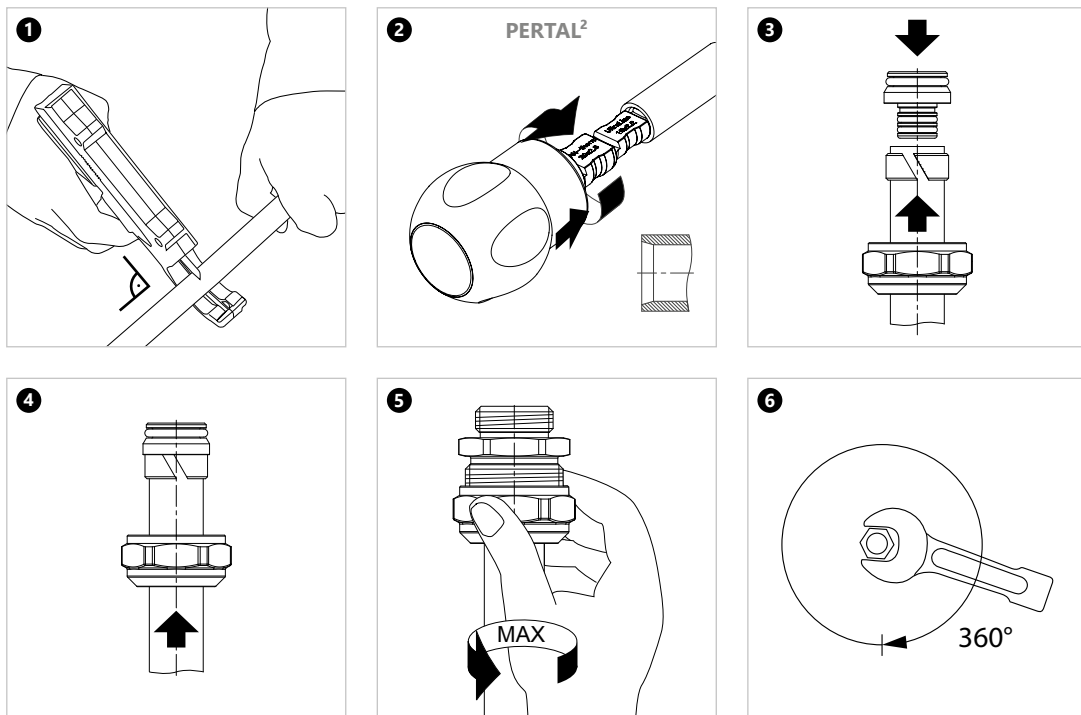

1. The selected KAN-therm ultraLINE pipe should be cut perpendicularly to the axis to the required length by means of pipe cutters. It is not allowed to use tools or scissors which are faulty (blunt or chipped).
2. Calibrate the pipe and chamfer (only PERTAL² pipes) its inner edges with a calibrator but not deeper than to the aluminium layer.
3. Put a compression nut on the pipe and then place a compression ring at the end of the pipe, noting that it should be located at a distance from the edge of the pipe between 0,5 to 1 mm.
4. Insert the pipe fully over the coupling stub pipe (do not use any lubricants, do not make any twisting movement of the fitting in relation to the pipe).
5. As much as possible, tighten the nut over the pipe and the compression ring by hand, without using any additional tools – hand tightening only.
6. Tighten the nut over the pipe and compression ring with a spanner. When tightening, just one full 360° rotation is needed to obtain proper seal.

8.4 Assembly of adapters for metal pipes

KAN-therm system offer includes three types of adapters for connecting metal pipes.

G³/₄" 1709043005 and G¹/₂" 1709043003 copper pipe eurocone adapters can work with 15 mm nickel-plated copper pipes.

Universal 1709043010 pipe eurocone adapters can work with metal pipes (copper, nickel-plated copper, KAN-therm Steel and Inox systems pipes with a diameter of 15 mm). The design of the universal pipe eurocone adapter allows its multiple use.

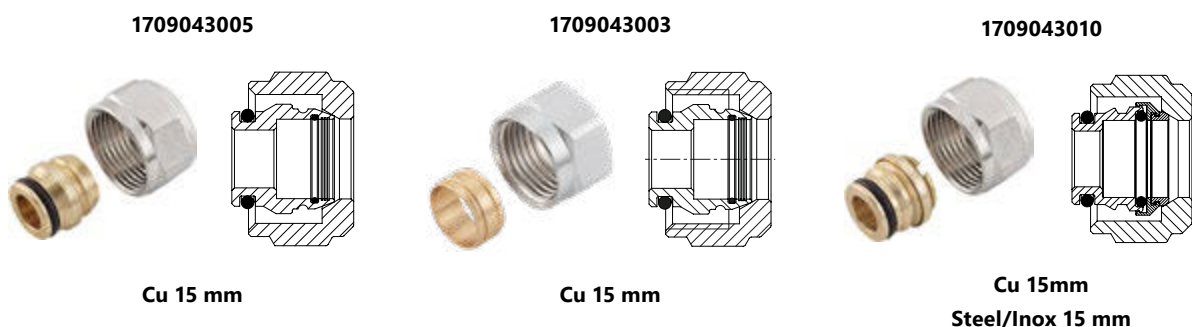

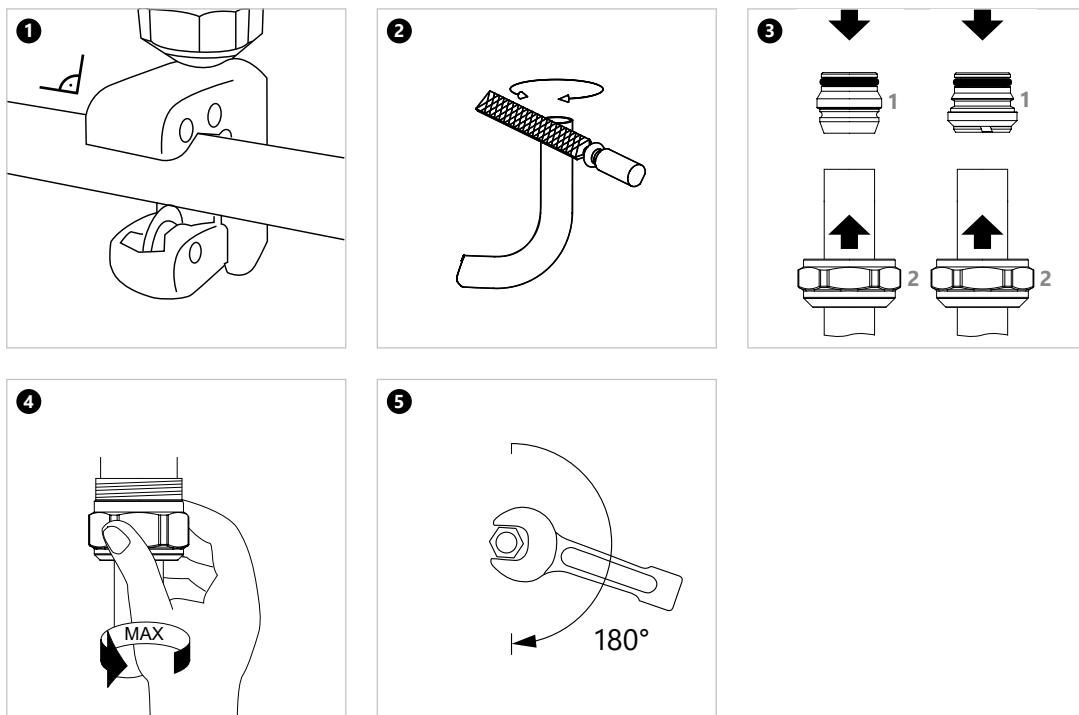

NOTE

To eliminate excessive overload on fittings by bending force, it is not recommended to bend pipes at a distance less than 10 external diameters from the fitting.

9 Transport and storage

PERT² and PEXC pipes as well as PERTAL² pipes can be stored at temperatures below 0 °C, then they should be protected against dynamic loads. They should be protected against mechanical damage during transport. Due to the sensitivity to ultraviolet rays, the pipes should be protected against direct long-term exposure to sunlight, both during storage, transport and assembly.

During storage, transport and assembly of pipes and fittings:

- avoid surfaces with sharp edges or loose sharp elements on its surface,
- do not shift directly on concrete surfaces,
- protect against dirt, mortar, oils, greases, paints, solvents, moisture chemicals, etc.,
- remove components from the original packaging immediately before assembly,
- If it is necessary to cut into insulation already fitted to a pipe (e.g. to fit it around a pipe fitting), take particular care not to damage the surface of the pipe. Use only suitable, sharp tools for cutting, which allow you to make a precise cut through the insulation layer without damaging the pipe material.



Detailed information about storage and transport of components can be found at en.kan-therm.com.



**KAN-therm
MULTISYSTEM**

> 35 | years of experience
on the installation
market



KAN-therm

ultraPRESS

**INNOVATIVENESS AND UNIQUENESS
- ONE SYSTEM, SIX FUNCTIONS**

Install the **future**

SYSTEM KAN-therm ultraPRESS

1	General information	45
2	Pipes in the KAN-therm ultraPRESS	46
2.1	PERTAL pipes with aluminum layer	46
2.2	PEXC, PERT and bluePERT pipes with EVOH layer and bluePERTAL with aluminium layer	48
2.3	Scope of use	50
3	Joints in multilayer installations with KAN-therm pipe with aluminium layer	51
3.1	„Press“ joints	51
3.2	Structure and features of KAN-therm 16-40 mm ultraPRESS fittings	52
3.3	Identification of KAN-therm ultraPRESS fittings	53
3.4	KAN-therm ultraPRESS fittings with diameters 50 and 63 mm	53
3.5	KAN-therm pressed fittings – assortment	54
3.6	Contact with chemicals, adhesives and sealants	56
3.7	Performing “press” type connections for KAN-therm ultraPRESS fittings	57
3.8	Assembly of KAN-therm ultraPRESS fittings with diameters: 16, 20, 25, 26, 32 and 40 mm	62
3.9	Assembly of KAN-therm ultraPRESS fittings with diameters 50 and 63 mm	64
3.10	Minimum assembly distances	65
3.11	Threaded joints for PERTAL pipes with aluminum layer	65
4	Transport and storage	68

SYSTEM KAN-therm ultraPRESS

1 General information

KAN-therm ultraPRESS is a state-of-the-art, complete installation system consisting of PERTAL polyethylene pipes with aluminum layer, as well as PPSU or brass fittings of Ø16–63 mm.

Connection of the system ultraPRESS elements is based on pressing a stainless steel sleeve on a pipe mounted on a stub of a fitting or coupling ("press" technique). The stub is equipped with O-Rings ensuring complete tightness of the joint and reliable operation of the installation.

The system is designed for indoor water supply installations (cold and hot potable water), central heating installations, cooling installations, technological heating installations and industrial installations (compressed air).

The ultraPRESS system offers the additional possibility of connecting PERT, PEXC and bluePERT pipes with an EVOH layer and bluePERTAL pipes with aluminium layer by using ultraPRESS fittings in brass and PPSU. In this case, the operating conditions for such a connection, described later in this guide, should be checked.

KAN-therm ultraPRESS is characterized by:

- high operating parameters (max. working temperature of 90 °C, permissible malfunction temperature – 100 °C),
- very low thermal elongation of PERTAL pipes with aluminum layer,
- complete lack of oxygen diffusion to installation water,
- guaranteed durability for over 50 years,
- universal pipe applications (one pipe for combined water supply and heating installations),
- resistance to hydraulic impact,
- high smoothness of internal surfaces,
- resistance to scaling,
- physiological and microbiological neutrality in potable water installations,
- environmentally friendly materials,
- easy and quick installation,
- easy and quick assembly (no chamfering or calibration of pipes with diameters of 16-32 mm required),
- low installation weight,
- possibility of executing joints in structural partitions,
- LBP function, i.e. indication of unpressed connections,
- Universality - PERT, PEXC and bluePERT pipes with EVOH layer and bluePERTAL pipes with aluminium layer can be connected.

2 Pipes in the KAN-therm ultraPRESS

2.1 PERTAL pipes with aluminum layer

Multilayer PERTAL pipes with aluminum layer in KAN-therm ultraPRESS system are offered in PE-RT II/Al/PE-RT II construction (diameter range of Ø16–63 mm).

They are made of the following layers: internal layer (base pipe) made of PE-RT polyethylene with increased thermal resistance, middle layer as laser butt-welded aluminium and external layer (coating) made of PE-RT polyethylene as well. An adhesive binding layer is applied between the aluminum and plastic layers.

The aluminum layer serves as a anti-diffusion barrier and lowers the thermal pipe elongation 8 times, as compared to uniform polyethylene pipes. Thanks to the butt welding of aluminium, all the pipe layers have constant, specified thickness and perfectly round cross-section.

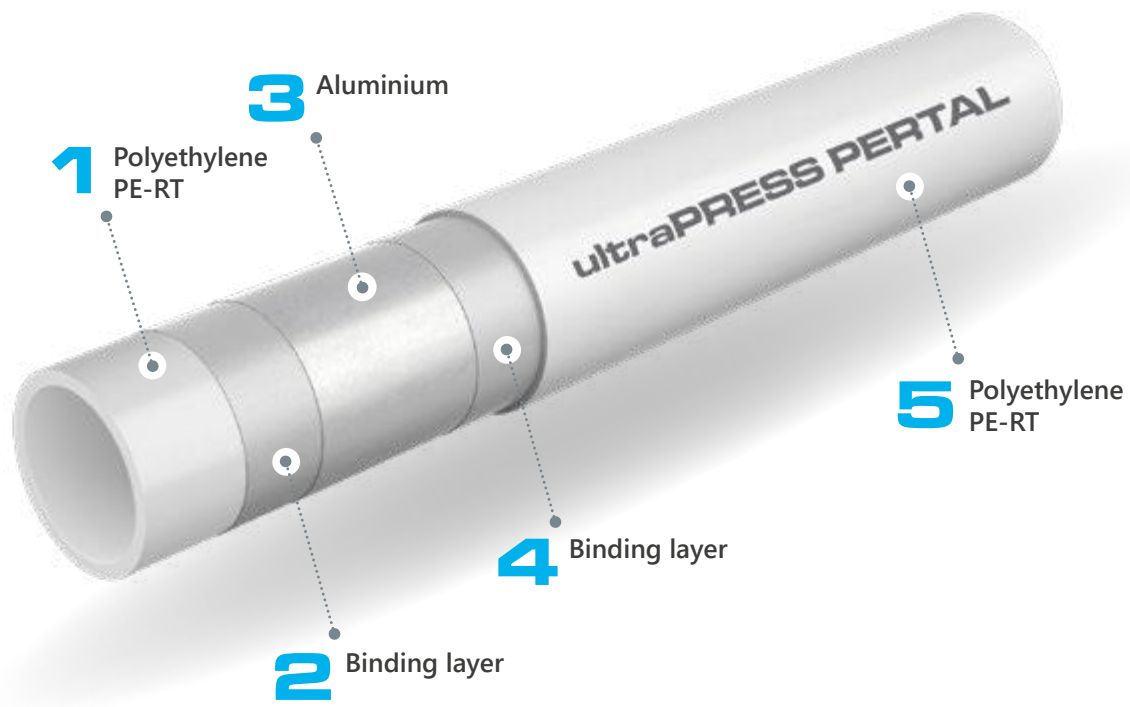

Cross-section of a PERTAL pipes with aluminium layer

Physical properties of PERTAL pipes with aluminum layer

Property	Symbol	Unit	Value
Linear elongation coefficient	α	mm/m × K	0,023 – 0,025
Thermal conductivity	λ	W/m × K	0,43
Minimal bending radius	R_{min}		5 × De - without tools 3,5 × De - while utilizing bending tools
Internal wall roughness	k	mm	0,007



KAN-therm ultraPRESS PERTAL pipes with aluminum layer

Marking, color of pipes

All pipes are marked with permanent descriptions with a 1-m span, containing i. a. the following indications:

Marking description	Example of marking
Name of manufacturer and/or trademark:	KAN-therm ultraPRESS PERTAL
Nominal external diameter x wall thickness	16 x 2
Pipe structure (material)	PE-RT II/Al/PE-RT II
Pipe code	1029196031
Number of standard or Technical Certificate	KIWA KOMO, DVGW
Application class/es with design pressure	Class 2/10 bar, Class 5/10 bar
Date of production	18.08.09
Other manufacturer markings, e.g. running meter, batch number	045 m



Notice – other, additional markings, e.g. numbers of certificates may also be inscribed on the pipe.

Pipe color: white.

Pipes are supplied in coils in lengths depending on the diameter of the pipe and its version, i.e. with or without thermal insulation.

Pipes without thermal insulation are also available in 5 m bars.

Dimension parameters of KAN-therm PERTAL pipes with aluminum layer

DN	External diameter x wall thickness	Wall thickness	Internal diameter	Weight by unit	Number in roll/bar	Water capacity
	mm x mm	mm	mm	kg/m	m	l/m
PERTAL						
16	16 x 2,0	2,0	12	0,129	200- 600 / -	0,113
20	20 x 2,0	2,0	16	0,152	100 / 5	0,201
25	25 x 2,5	2,5	20	0,239	50 / 5	0,314
26	26 x 3,0	3,0	20	0,296	50 / -	0,314
32	32 x 3,0	3,0	26	0,365	50 / 5	0,531
40	40 x 3,5	3,5	33	0,510	25 / 5	0,855
50	50 x 4,0	4,0	42	0,885	- / 5	1,385
63	63 x 4,5	4,5	54	1,265	- / 5	2,290

2.2 PEXC, PERT and bluePERT pipes with EVOH layer and bluePERTAL with aluminium layer

The basic configuration of the ultraPRESS system is to combine ultraPRESS fittings with PERTAL pipe with aluminium layer, in the entire diameter range 16-63 mm. The special design of ultraPRESS fittings gives the additional option of connecting PERT, PEXC, bluePERT and bluePERTAL pipes in the 16-25 mm diameter range.

The operating conditions for pipes, depending on the application class, type of pipe and its diameter, are presented in the table further on in this guidebook.



KAN-therm ultraPRESS tee in combination with bluePERT, PEXC and PERT pipe.

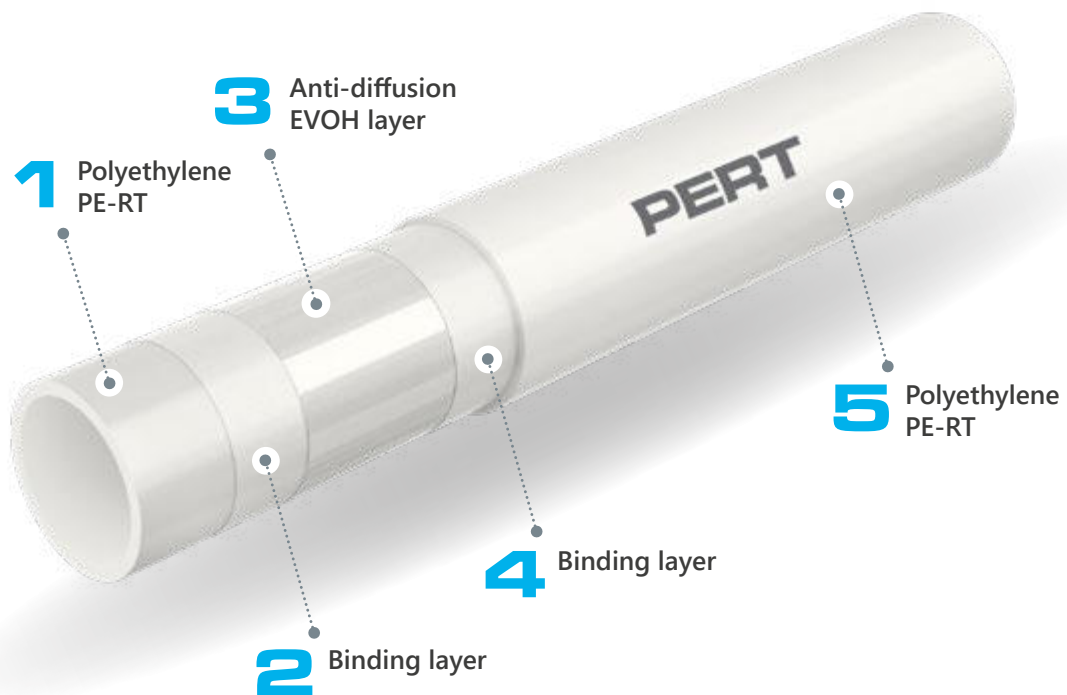

Cross-section of PERT pipe with EVOH layer.

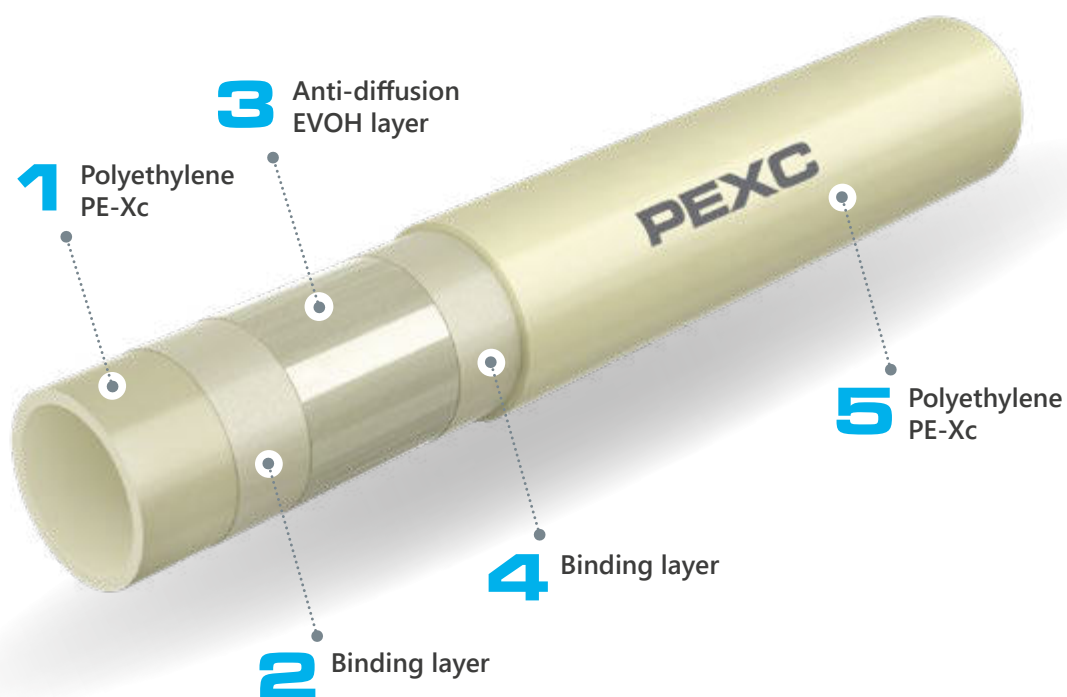

Cross-section of PEXC pipe with EVOH layer.

Dimensional parameters of KAN-therm PEXC, PERT and bluePERT pipes with EVOH layer.

DN	External diameter × wall thickness	Wall thickness	Internal diameter	Weight by unit	Lenght in roll	Water capacity
	mm × mm	mm	mm	kg/m	m	l/m
KAN-therm PEXC pipes						
16	16 × 2,0	2,0	12,0	0,094	200	0,113
20	20 × 2,0	2,0	16,0	0,117	200	0,201
KAN-therm PERT pipes						
16	16 × 2,0	2,0	12,0	0,094	200	0,113
20	20 × 2,0	2,0	16,0	0,117	200	0,201
KAN-therm bluePERT pipes						
16	16 × 2,0	2,0	12,0	0,094	200, 600	0,113
20	20 × 2,0	2,0	16,0	0,117	200, 300, 600	0,201
25	25 × 2,5	2,5	20,0	0,166	220	0,314

Dimensional parameters of KAN-therm bluePERTAL pipes with aluminium layer

DN	External diameter × wall thickness	Wall thickness	Internal diameter	Weight by unit	Lenght in roll	Water capacity
	mm × mm	mm	mm	kg/m	m	l/m
KAN-therm bluePERTAL pipes						
16	16 × 2,0	2,0	12,0	0,100	200, 600	0,113

2.3 Scope of use

KAN-therm ultraPRESS pipes and fittings are in full compliance with all applicable standards, which guarantees their long-term and reliable operation as well as full security of assembly and use of the installation.

- PPSU and brass ultraPRESS joints utilizing pressed rings and threaded brass fittings: compliance with approved for use by the National Institute of Hygiene,
- PERTAL pipes: compliance with PN-EN ISO 21003–2:2009, approved for use by the National Institute of Hygiene,
- PEXC pipes: compliance with PN-EN ISO 15875–2:2004, approved for use by the National Institute of Hygiene,
- PERT pipes: compliance with PN-EN ISO 21003-2, approved for use by the National Institute of Hygiene,
- bluePERT pipes: compliance with PN-EN ISO 21003-2.
- bluePERTAL pipes: compliance with PN-EN ISO 21003-2.

The working parameters and scopes of use of KAN-therm PERTAL pipe installations are presented in the table.

Application (acc. to ISO 10508)	T_{op}/T_{max} [°C]	Dimensions [mm]	Operating pressure P_{op} [bar]		Connection type	
			PERTAL	PERTAL	connection "press"	screw connection
					PERTAL	PERTAL
Cold tap water Hot tap water [Application class 1(2)]	60(70)/80	16 × 2,0	10	10	+	+
		20 × 2,0			+	+
		25 × 2,5			+	+
		26 × 3,0			+	+
		32 × 3,0			+	-
		40 × 3,5			+	-
		50 × 4,0			+	-
Radiant heating, low-temperature radiator heating [Application class 4]	60/70	16 × 2,0	10	10	+	+
		20 × 2,0			+	+
		25 × 2,5			+	+
		26 × 3,0			+	+
		32 × 3,0			+	-
		40 × 3,5			+	-
		50 × 4,0			+	-
Radiator heating [Application class 5]	80/90	16 × 2,0	10	10	+	+
		20 × 2,0			+	+
		25 × 2,5			+	+
		26 × 3,0			+	+
		32 × 3,0			+	-
		40 × 3,5			+	-
		50 × 4,0			+	-
63 × 4,5	+	-				

For all classes and diameters, failure temperature $T_{mal} = 100$ °C

The operating parameters and applications scope of the KAN-therm ultraPRESS system with the use of PEXC, PERT, bluePERT and bluePERTAL pipes are presented in the table:

Application class	Operating pressure P_{op} [bar]					Connection type	
	T_{op}/T_{max}	Dimensions	PEXC	PERT	bluePERT, bluePERTAL*	connection "press"	screw connection
	[°C]	[mm]				PEXC, PERT, bluePERT, bluePERTAL*	PEXC, PERT, bluePERT, bluePERTAL*
Cold tap water	20	16 × 2,0	10	10	-	+	+
		20 × 2,0	10	10	-	+	+
Hot tap water [Application class 1]	60/80	16 × 2,0	10	10	-	+	+
		20 × 2,0	8	8	-	+	+
Hot tap water [Application class 2]	70/80	16 × 2,0	10	10	-	+	+
		20 × 2,0	6	8	-	+	+
Underfloor heating, Low temperature heating, radiant heating [Application class 4]	60/70	16 × 2,0*	10	10	8	+	+
		20 × 2,0	8	8	6	+	+
		25 × 2,5	-	-	6	+	-
Radiator heating [Application class 5]	80/90	16 × 2,0	8	8	-	+	+
		20 × 2,0	6	6	-	+	+

Operating pressure calculated according to the standards: PN-EN ISO 15875-2:2004 for PEXC pipes and PN-EN ISO 21003-2:2009 for PERT, bluePERT and bluePERTAL pipes.

3 Joints in multilayer installations with KAN-therm pipe with aluminium layer

The basic method of connecting pipes in the KAN-therm ultraPRESS is using the "press" technique utilizing a radially pressed stainless steel sleeve. Threaded joints may also be used to connect pipes to devices and appliances.

3.1 „Press“ joints

The execution of „press“ type joints is based on radially pressing stainless steel sleeve located on the stub of a fitting. The stub is equipped with O-Ring sealing made of synthetic EPDM rubber, resistant to high temperatures and pressure. The sleeve is pressed with a manual or electric press tool equipped, depending on the diameter of the pipe, with "U", "C", or "TH" profile jaws (standard pressing). Such a connection allows conducting the installation in structural partitions (in flooring finishing coats and under layers of plaster).

Press KAN-therm fittings, depending on the diameter, are available in three construction types. They differ in terms of outer appearance, methods of assembly and some functions:

- KAN-therm ultraPRESS fittings (with colored base ring) – diameters 16, 20, 25, 26, 32 and 40 mm,
- KAN-therm ultraPRESS fittings – diameters 50 and 63 mm,
- KAN-therm ultraPRESS fittings (without base ring - old construction) - diameters 50 and 63 mm.

3.2 Structure and features of KAN-therm 16-40 mm ultraPRESS fittings

Thanks to their special structure this type of KAN-therm ultraPRESS fittings is characterized by:

- a function of signaling not-pressed LBP joint (does not refer to the fittings with 40 mm diameter),
- possibility of using U, C or TH profile jaws interchangeably (depending on the diameter and jaw manufacturer),
- elimination of need to chamfer the edge of the pipe,
- precise jaws positioning on the ring,
- colorful, plastic specifying the fitting diameter rings.

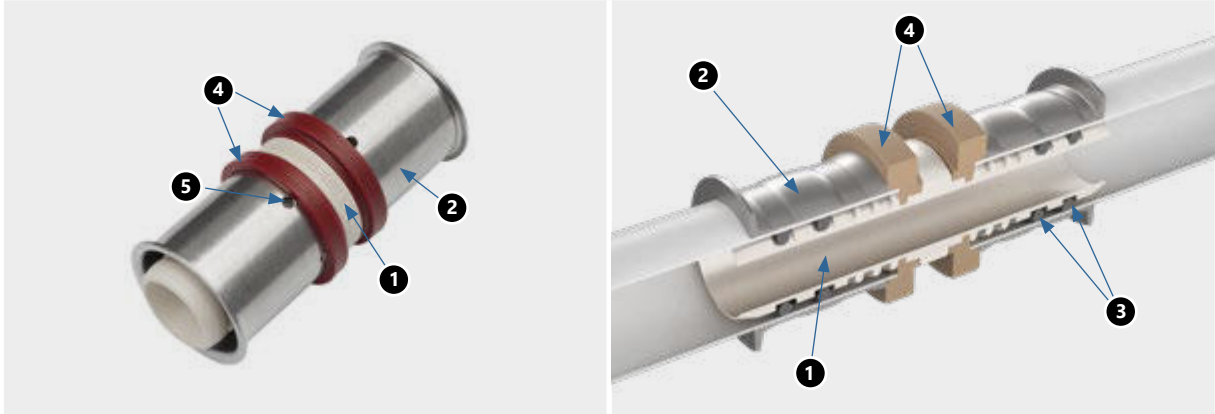

View and cross-section of a KAN-therm ultraPRESS with a colored ring fitting

1. Coupling body
2. Pressed stainless steel sleeve with inspection holes
3. EPDM O-Rings
4. Colored base ring
5. Inspection holes in the stainless steel sleeve

LBP – „Leak Before Press“ – an mistakenly not-pressed joints are signaled by a water leak at the stage of preliminary non-pressurized installation filling, before the pressure test. This function complies with DVGW guidelines (“controlled leak”).

! **Notice:**

According to DVGW guidelines, the LBP function can be seen as controlled leakage at a pressure of:

- in compressed air installations from 1,0 to 3,0 bar,
- in installations filled with water from 1,0 to 6,5 bar.



LBP function in action – leak before press

3.3 Identification of KAN-therm ultraPRESS fittings

Each of 16 mm up to 40 mm KAN-therm ultraPRESS fitting is equipped with a special plastic base ring, the color of which depends on the diameter of the pipe being connected. This solution facilitates the identification of the fitting and, in consequence, installation works at the construction site and in the warehouse. Irrespective of the color identification, each stub has a marking stating the diameters of pipes to be connected.

The dimensions of pipes (external diameter × wall thickness) are also inscribed on the stainless steel sleeve.



* 40 mm fittings do not possess LBP function itself

3.4 KAN-therm ultraPRESS fittings with diameters 50 and 63 mm

All fittings of diameter – 50 and 63 mm (including 50 and 63 mm stubs of reduction joints) differ in construction from their substitutes with smaller diameters. They are distinguished by plastic transparent base ring embedded on a fittings body, the lack of LBP function and a slightly different method of assembly in terms of pipe ending treatment.

i **Note! Old designs of 50 and 63 mm diameter fittings may be available on the market, characterized by the absence of the LBP function, the lack of a base ring and a different way of positioning the jaws. Detailed installation guidelines are described later in this guide.**

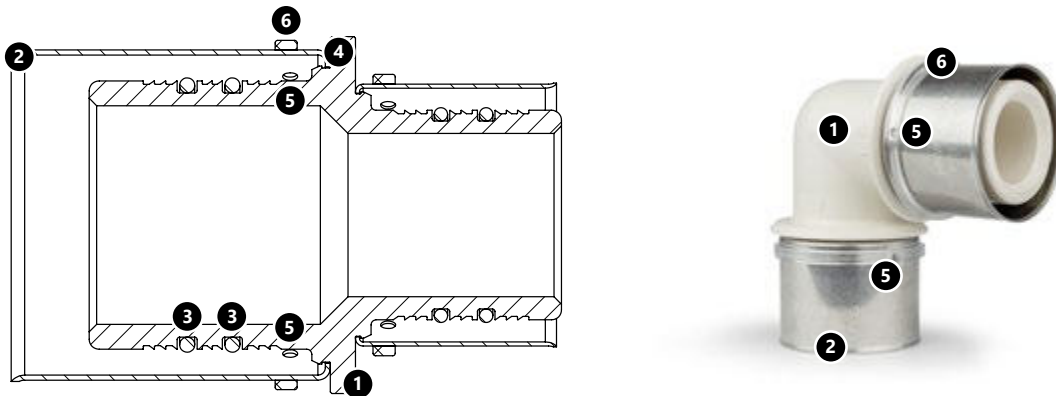

View and cross-section of KAN-therm ultraPRESS fitting without a colored ring.

1. Coupling body
2. pressed stainless steel sleeve
3. EPDM O-Rings
4. Rings positioning the stainless steel sleeve on the body
5. Inspection holes in the sleeve
6. Plastic transparent base ring

3.5 KAN-therm pressed fittings – assortment

The KAN-therm ultraPRESS system offers a wide selection of radially pressed fittings:

- elbows and tees, couplings,
- elbows, tees and other fittings with 15 mm nickel-plated pipes for connecting to radiators and appliances,
- fittings with male and female threads, and eurocone adapters,
- tap connections,
- transition couplings.

KAN-therm ultraPRESS fittings are offered in two structural variations:

KAN-therm ultraPRESS fittings with colored ring (diameters 16–40 mm)



KAN-therm ultraPRESS radially pressed fittings



KAN-therm ultraPRESS pressed fittings with 15 mm pipes for connecting to radiators*



KAN-therm ultraPRESS pressed fittings with threads and eurocone adapters*



available until stock lasts



KAN-therm ultraPRESS pressed fittings – tap connections*

- i** *The application of KAN-therm ultraPRESS system fittings for connecting radiators and water supply taps is described in the chapter titled "Connections of water supply and heating installation devices in the KAN-therm system".



KAN-therm ultraPRESS pressed couplings – transition fittings

KAN-therm ultraPRESS without colored ring fittings (diameters 50–63 mm)



KAN-therm ultraPRESS fittings



Threaded KAN-therm ultraPRESS fittings



The application of KAN-therm ultraPRESS system fittings for connecting radiators and water supply taps is described in the chapter titled “Connections of water supply and heating installation devices in the KAN-therm system”.

All KAN-therm ultraPRESS fittings with the diameter range 16-63 mm are made of a reliable structural material polyphenylsulfone (PPSU) or high quality CW617N brass.

Polyphenylene sulfone (PPSU) is a proven construction material that has been used for many years in plumbing systems as a raw material for the manufacture of connectors and fittings, pump housings, heat exchanger components, parts and cartridges for tap faucets. In KAN-therm ultraPRESS systems, elbows, tees, connectors, reductions are manufactured from it.

The basic properties of PPSU determining the possibility of using this material as a raw material for the production of fittings and connectors for installations of water, hot water, and central heating are:

- neutrality in contact with water and food, confirmed by numerous studies of the world’s leading research institutes,
- high resistance to aging processes as a result of temperature and pressure, giving the possibility to use this material in hot water and central heating installations and obtaining more than 50-year durability of fittings,
- adequate resistance to water with high chlorine content at high temperatures,
- the absence of permanent deformation of the material subjected to mechanical loads at high temperatures, which determines the stability over time of the dimensions of fittings (resistance to material creep), and therefore the tightness of press connections,
- high resistance to impact and mechanical loads,
- low weight compared to metal fittings.

3.6 Contact with chemicals, adhesives and sealants



- Secure the plastic (PPSU) elements of KAN-therm system against contact with paints, primers, solvents or materials containing solvents, e.g. varnish, aerosols, expanding foams, adhesives, etc. In unfavorable circumstances, these substances could potentially damage the plastic elements of the system.
- Make sure that substances sealing the joints, cleaning solutions or solutions used to insulate KAN-therm system components do not contain any compounds which could cause stress cracks. These include ammonia, solutions containing ammonia, aromatic solvents and compounds retaining oxygen (e.g. ketone or ether) or chlorinated hydrocarbons.
- Do not use expanding foams based on methacrylate, isocyanate and acrylate when in contact with plastic (PPSU) elements of KAN-therm system. Avoid direct contact of plastic (PPSU) fittings and pipes with adhesive tapes and adhesives for insulation.
- In threaded fittings, use a proper amount of tow as to leave the ending of the thread bare and visible. Too much tow may disrupt the thread. Winding tow just above the first coil of the thread will prevent the tow from tangling up and the thread from being damaged.
- When making screwed (threaded) connections, precautions should be taken in the form of: using the right amount of sealing material (tow) and correct tightening torque. In unfavorable situations, a threaded connection made with too much sealant and/or overtightened can lead to critical mechanical stresses in the connector material and damage to the product.
- Minimise the risk of prolonged dampness and condensation on the surface of pipes and fittings.
- Do not use brass components of the KAN-therm system in environments where ammonia of biological origin is present or may be present, particularly in livestock facilities.
- Pay attention to the connection of different types of threads. In unfavorable cases, there may be a collision of the outlines of the female and male threads, which can lead to building up excessive mechanical stress in the fitting material and consequent damage.



Notice!

Do not use chemical sealants or adhesives.

Summary of assembly properties for ultraPRESS fittings

Fitting structure	Scope of diameters	pressing profile	Pipe ending treatment method		
			calibration	edge chamfering	
ultraPRESS with colored ring 	Color of ring	U or TH	16	No	No
			20	No	No
			25	Recommended	No
		U, C or TH ¹⁾	26 ²⁾	Recommended	No
			32	Recommended	No
			40	Yes	Yes
ultraPRESS without colored ring 	50	TH	Yes	Yes	
	63		Yes	Yes	

¹⁾ jaws name (profile) depends on the manufacturer

²⁾ In 2024 REMS C26 jaws has been renamed into U26. KAN-therm branded jaws dedicated for 26 mm diameter remain C26.



Note: Only calibrators included in the system's offer should be used to calibrate KAN-therm ultraPRESS system pipes.

3.7 Performing "press" type connections for KAN-therm ultraPRESS fittings

Tools

To perform connections in KAN-therm ultraPRESS, use tools available in KAN-therm system offer - see the table below.

Manufacturer	Press type		Diameter [mm]	Jaws/collars		Adapter	
	Description	Code		Description	Code	Description	Code
KAN-therm	AC 3000 DC 4000	1936267239 1936267238	16	U	1936267257	-	-
			16	TH	1936267241	-	-
			20	U	1936267258	-	-
			20	TH	1936267242	-	-
			25	U	1936267259	-	-
			25	TH	1936267271	-	-
			26	C	1936267245	-	-
			26	TH	1936267243	-	-
			32	U	1936267260	-	-
			32	TH	1936267244	-	-
			40	U	1936267261	-	-
			40	TH	1936267272	-	-

Manufacturer	Press type		Diameter [mm]	Jaws/collars		Adapter				
	Description	Code		Description	Code	Description	Code			
NOVOPRESS	ACO203XL EFP203	1948267181 1948267210	14	U ³⁾	1936267231	-	-			
			14	TH ³⁾	1936267222	-	-			
			16	U	1936267232	-	-			
			16	TH	1936267223	-	-			
			20	U	1936267233	-	-			
			20	TH	1936267224	-	-			
			25	U	1936267234	-	-			
			25	TH	1936267225	-	-			
			26	TH	1936267226	-	-			
			32	U	1936267235	-	-			
			32	TH	1936267227	-	-			
			40	U	1936267236	-	-			
			40	TH	1936267228	-	-			
			50	[OP]TH	1936267229	ZB203	1948267000			
	63	[OP]TH	1936267230							
	ACO103	1936055004 - "U" 1936055005 - "TH"	16	U	1936267113	-	-			
			16	TH	1936267108	-	-			
			20	U	1936267114	-	-			
			20	TH	1936267109	-	-			
			25	U	1936267115	-	-			
			25	TH	1936121003	-	-			
			26	TH	1936267110	-	-			
			32	U	1936267116	-	-			
			32	TH	1936267111	-	-			
			14	U ³⁾	1936267220	-	-			
			14	TH ³⁾	1948267107	-	-			
REMS			Power-Press SE Akku-Press Power-Press ACC Eco Press ¹⁾	1936267160 1936267152 1936267219 1936267174 ¹⁾	16 ¹⁾	U	1936267122	-	-	
	16 ¹⁾	TH			1948267109	-	-			
	20 ¹⁾	U			1936267125	-	-			
	20 ¹⁾	TH			1948267114	-	-			
	25 ¹⁾	U			1936267127	-	-			
	25 ¹⁾	TH			1948267116	-	-			
	26 ¹⁾	U ²⁾			1936267130	-	-			
	26 ¹⁾	TH			1936267101	-	-			
	32	U			1936267137	-	-			
	32	TH			1936267103	-	-			
	40	U			1936267139	-	-			
	40	TH			1936267105	-	-			
	50	TH			1936267134	-	-			
	63	TH			1936267136	-	-			
	KLAUKE	KAN-therm Mini			1936055008	16	U	1936267273	-	-
						20	U	1936267274	-	-
25			U	1936267275		-	-			
26			U	1936267276		-	-			
32			U	1936267277		-	-			
16			TH	1936055015						
20			TH	1936055016						
26			TH	1936055014						
32			TH	1936055017						

¹⁾ Limited diameter range - use selected press jaws

²⁾ From 2024, by decision of the REMS tool manufacturer, the C 26 jaw was renamed the U 26 jaw.

³⁾ Tools for installation of ultraPRESS 14x2 connector - KAN-therm Surface heating and cooling

To perform a connections in KAN-therm ultraPRESS, other tools available on the market can also be utilized - see the table below.

Size	Manufacturer	Press machine	Jaws/collars	Press profile
16–40 mm	Novopress	Comfort – Line ACO 102 Basic – Line AFP 101	16–40 mm PB1 jaws	
16–63 mm	Novopress	Comfort – Line ECO 202 Comfort – Line ACO 202 Basic – Line EFP 202 Basic – Line AFP 202 Basic – Line EFP 2 adapter ZB 201 adapter ZB 203	16–40 mm PB2 jaws 50–63 mm jaws for adapters	Ø 16–40 mm – U, TH profile Ø 50–63 mm – TH profile
16–20 mm	Klauke	MP20	16–20 mm inserts	
16–32 mm	Klauke	i-press mini MAP2L mini MAP1 AHP700LS PKMAP2 HPU32 MP32	16–32 mm mini jaws 16–32 mm jaws for mini inserts 16–32 mm inserts	Ø 16–40 mm – U profile Ø 16–32 mm – TH profile Ø 63 mm – TH profile Notice: Ø 40–50 mm TH profile (KSP 11) – non-compatible with the KAN-therm system
16–63 mm	Klauke	i-press medium UAP3L UAP2 UNP2 i-press medium UAP4L HPU2 AHP700LS PKUAP3 PKUAP4	16–40 mm tongs 16–32 mm tongs for inserts 40–63 mm tongs for inserts	
16-40 mm	HILTI	NPR 019 IE-A22 NPR 19-22	NPR PM jaws 16-40 mm	16-32 mm – U, TH profile 40 mm – U profile
16-40 mm, 63 mm	HILTI	NPR 032 IE-A22 NPR 32-22 NPR 32 P-22	NPR PS jaws 16-50 mm NPR PR jaws 40-63 mm	16-32 mm – U, TH profile 40 mm – U profile 63 mm – TH profile
16-40 mm, 63 mm	HILTI	NPR 032 PE-A22 NPR 32 XL-22	NPR-PS jaws 16-40 mm NPR PR jaws 63 mm	16-32 mm – U, TH profile 40 mm – U profile 63 mm – TH profile
16–40 mm	REMS	Mini-Press ACC	16–40 mm mini tongs	Ø 16–40 mm – U, TH profile
16–63 mm	REMS	Power-Press E Power-Press 2000 Akku-Press ACC	16–63 mm tongs	Ø 50–63 mm – TH profile
16–40 mm	Rothenberger	Standard Romax 4000 Compact Romax AC/Akku Standard Romax 3000 Akku Romax 3000 AC Romax AC ECO	ONLY KAN-therm jaws	Ø 16–40 mm – profil TH Ø 16–40 mm – profil U

Tools offered by the KAN company available as single elements or in complete sets..

KAN-therm tools:



1. Electric press KAN-therm AC 3000
2. Battery-powered press KAN-therm DC 4000
3. „U“ KAN-therm jaws
4. „TH“ KAN-therm jaws
5. „C“ KAN-therm jaws

NOVOPRESS tools:



1. Battery-powered press ACO103
2. PB1 14–32 mm jaws

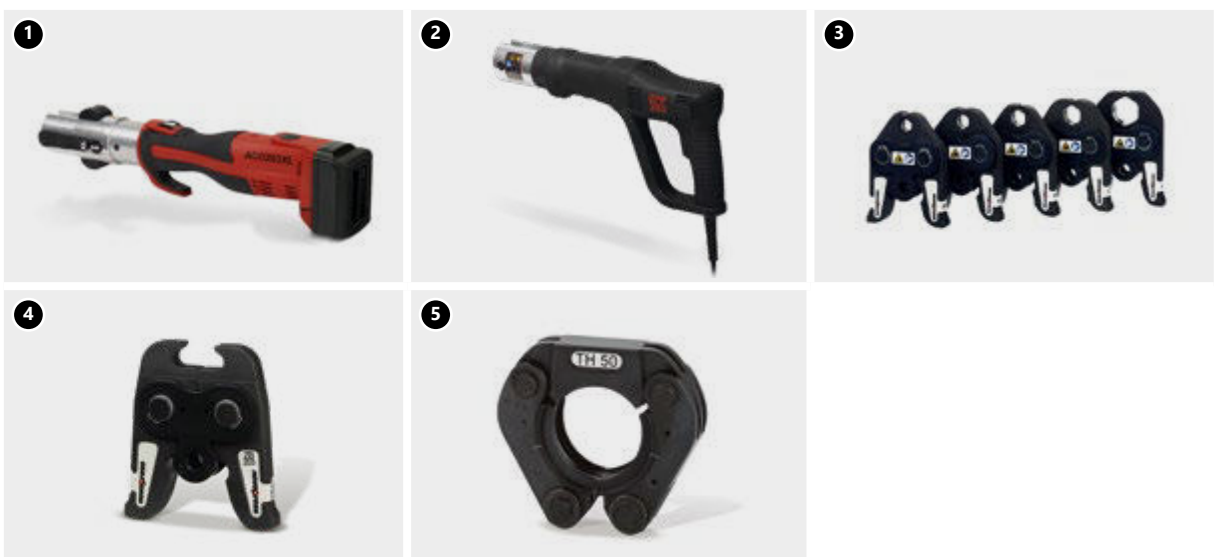

1. Battery-powered press ACO203XL
2. Electric press EFP203
3. PB2 14–40 mm jaws
4. Adapter ZB203 (50 and 63)
5. Snap On 50 and 63 mm collars

REMS tools:

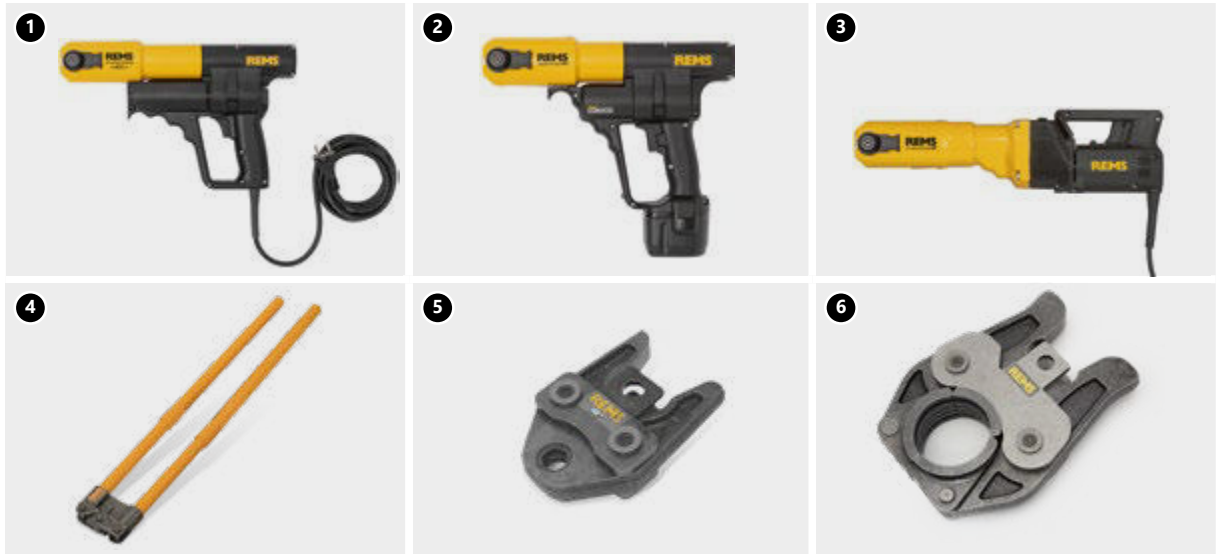

1. Electric press Power-Press ACC
2. Battery-powered press Akku-Press
3. Electric press Power-Press SE
4. Manual press tool Eco-Press (14–25(26) mm)
5. 14–40 mm jaws
6. 50–63 mm jaws

KLAUKE tools:



1. Battery-powered press KAN-therm Mini
2. SBM U 16–32 mm jaws
3. SBM TH 16–32 mm jaws

! Notice

Depending on the structure of the KAN-therm ultraPRESS fitting and its diameter, the following jaw profiles must be used for pressing:

KAN-therm ultraPRESS fittings:

- „U” or „TH” profile for diameters 16-40 mm.

KAN-therm ultraPRESS fittings:

- „TH” profile – for diameters: 50 and 63 mm.



! Tools – work safety

Before starting any works, make sure you read the instruction manual and learn the principles of safe work. All tools must be used according to their dedication and the manufacturer's instruction manual. During the use of tools, one must observe the terms of regular inspections and all applicable safety regulations. Using tools against their designed use may lead to their damage or to the damage of accessories and pipes. It may also lead to the occurrence of leaks in installation joints.

3.8 Assembly of KAN-therm ultraPRESS fittings with diameters: 16, 20, 25, 26, 32 and 40 mm

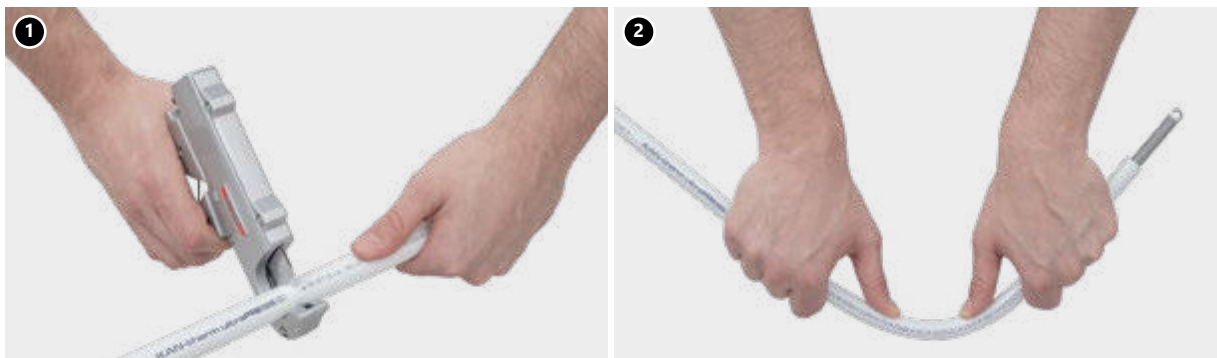

1. Using a pipe cutter for PERTAL pipes or a pipe roller cutter, cut the pipe perpendicularly to its axis at the required length.
Notice! Use only sharp, non-chipped cutting tools.
2. Give the pipe its desired shape. Bend the pipe using an inner or outer spring. Observe the minimum radius $R > 5 D_e$ requirement. When using mechanic pipe benders for diameters 16 – 20 mm, the minimum radius is $R > 3,5 D_e$. Execute all bends at a distance of $10 \times D_e$ from the nearest joint.

In the case of KAN-therm ultraPRESS fittings, (16-32 mm) pipe endings do need not to be chamfered, provided that sharp cutting tools are used and that the pipe is mounted using a proper shape fitting. For bigger diameters (25 and more), we suggest the use of a calibrator to allow the pipe to slide easily onto the stub.

The calibration of the pipe is obligatory for 40 mm diameter.

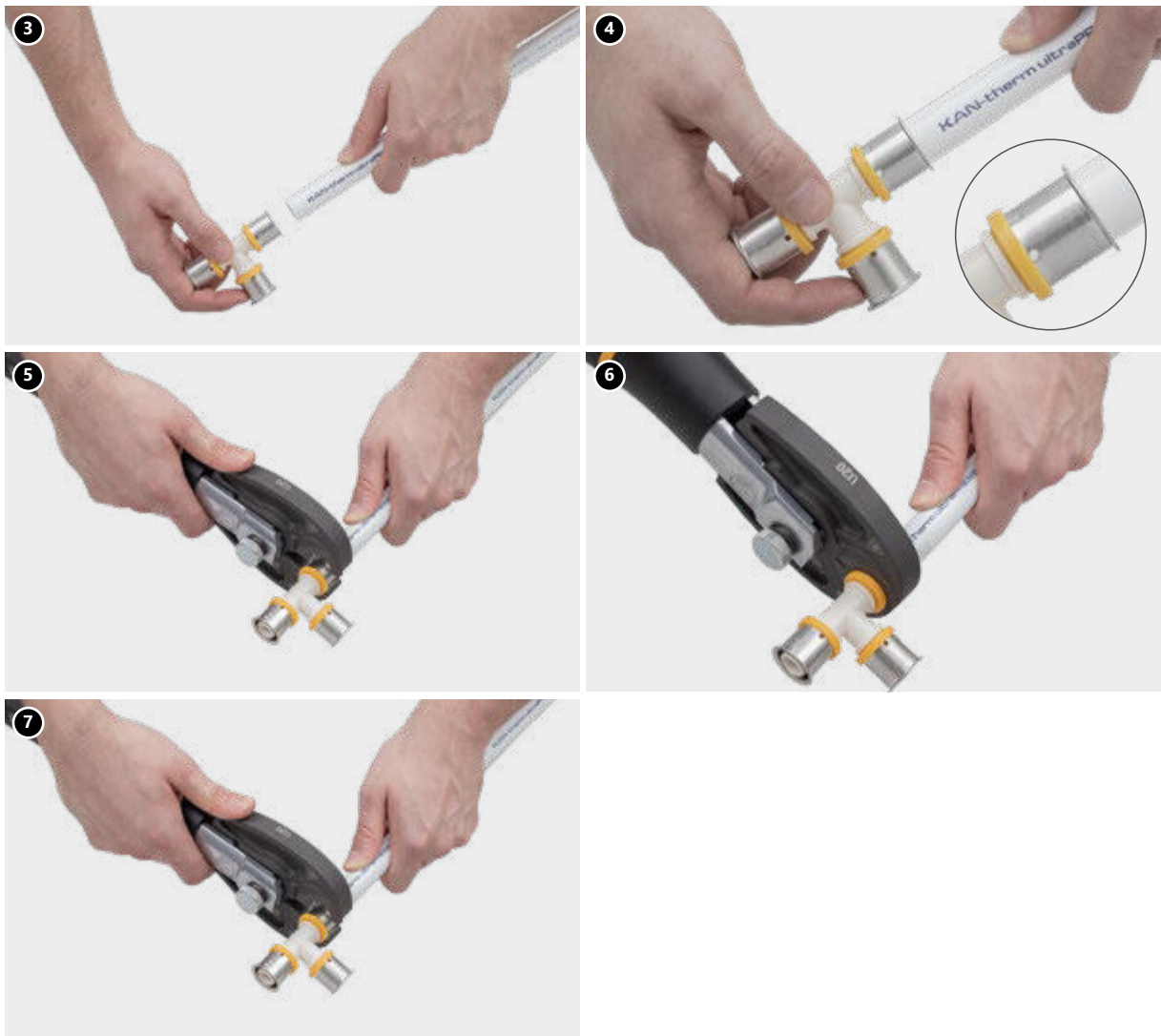

3. Slide the pipe into the fitting until it stops – axis mount of the pipe on the stub of the fitting is required. Check the depth of the fit – the edge of the pipe must be visible in inspection holes.
4. Check the pipe insertion depth - control holes in steel sleeve should be completely covered by the pipe slid in the fitting.
5. Place the jaws precisely on the stainless steel sleeve between the plastic ring and the collar of the sleeve, perpendicularly to the axis of the stub ("U" type profile). In the case of the "TH" profile, the jaws are positioned on the plastic ring (the ring must be embraced by the external groove of the jaw). In both cases, the structure of the joint makes it impossible for the jaws to slide off in the process of pressing.
6. Start the drive of the press machine and perform the connection. The process of pressing ends when the jaws of the tool completely close on the joint. Fitting may be pressed on a pipe only once.
7. Unlock the jaws and remove the tool from the fitting. The joint is ready for a pressure test



Notice

„Press“ type joints should be executed above ambient temperature of 0 °C. Before starting any works, read the instruction manuals for all tools and learn the principles of safe work.

3.9 Assembly of KAN-therm ultraPRESS fittings with diameters 50 and 63 mm

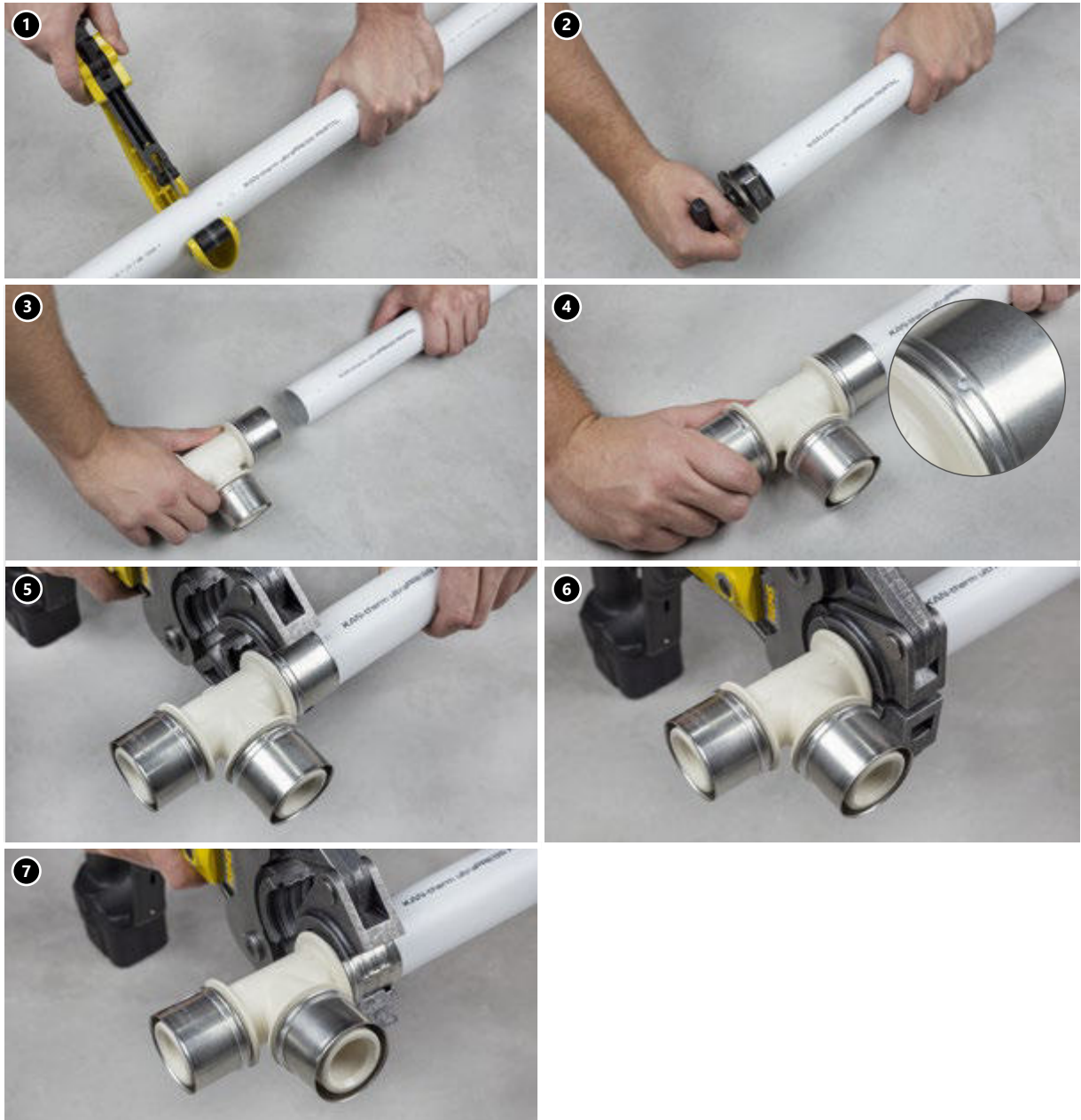

1. Using a pipe cutter for PERTAL pipes or a pipe roller cutter, cut the pipe perpendicularly to its axis at the required length.
2. Calibrate the pipe and chamfer its inner edge using a calibrator. The aluminum layer should remain intact. The edge of the pipe must not have any chips or splinters.
3. Slide the pipe into the fitting until it stops. Check the depth of the joint – the inspection holes must be completely covered by the pipe.
4. Check the pipe insertion depth - control holes in steel sleeve should be completely covered by the pipe slid in the fitting.
5. Place the jaws perpendicularly on the stainless steel sleeve so the jaws are positioned on the transparent plastic ring (the ring must be embraced by the external groove of the jaw). The structure of the joint makes it impossible for the jaws to slide off in the process of pressing.
6. Place the jaw of the press tool on the ring so that it contacts the flange of the connector. The outer edge of the jaw should be pressed against, but not encompass, the connector flange*. Start the press drive and make the connection. The pressing process continues until the jaws of the tool are completely closed. Pressing the ring on the pipe can be done only once.
7. Unlock the jaws and remove the tool from the clamped ring. The connection is ready for the pressure test.

*Refers to the old design of connectors, without the base ring.



Notice

„Press“ type joints should be executed above ambient temperature of 0 °C. Before starting any works, read the instruction manuals for all tools and learn the principles of safe work.

Bending radius of KAN-therm ultraPRESS PERTAL pipes with aluminum layer

Pipe diameter [mm]	Minimal bending radius R_{min} [mm]	
	Bending without tools ($R_{min} \geq 5 \times De$)	Bending with shaping tools ($R_{min} \geq 3,5 \times De$)
16 × 2,0	80	56
20 × 2,0	100	70
25 × 2,5	125	88
26 × 3,0	130	91
32 × 3,0	-	112
40 × 3,5	-	140
50 × 4,0	-	175
63 × 4,5	-	221

3.10 Minimum assembly distances

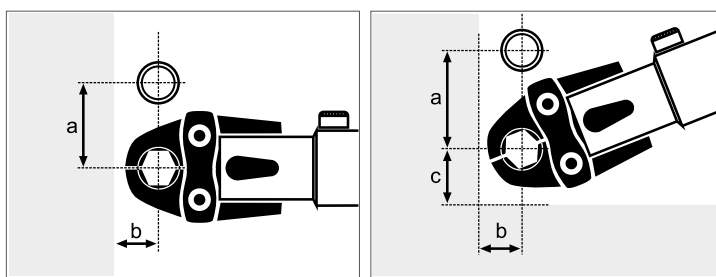

Rys. 1

Rys. 2

Ø [mm]	Pic. 1		Pic. 2		
	a [mm]	b [mm]	a [mm]	b [mm]	c [mm]
16	42	16	58	19	31
20	46	18	58	20	34
25 / 26	53	21	62	23	37
32	62	27	67	27	45
40	72	31	77	31	51
50	100	67	100	67	70
63	128	90	128	100	88

Above table gives indication for REMS 2-segment jaws (16-40 mm) and REMS 4-segment jaws (50-63 mm).

3.11 Threaded joints for PERTAL pipes with aluminum layer

Threaded joints for multilayer KAN-therm pipes are executed using two types of fittings:

- "barrel" union adapter (inlet connection),
- eurocone adapter with compression ring.

Threaded fittings (inlet connections)

Fittings of this type are made of brass. Each fitting consists of a body with a stub equipped with two O-Rings (used for fitting pipe ends) and a sealing cone (Eurocone type), as well as a threaded nut. Such joints are compatible with KAN-therm brass fittings with male threads, such as elbows, tees, tap connections with specially formed sockets (for sealing cone threads with O-Rings).

Dimensions of nut threads:

- 1/2" - for diameters 14 and 16,
- 3/4" - for diameters 14, 16 and 20,
- 1" - for diameters 20, 25 and 26.



1. Connection adapter (inlet connection)
2. Fittings with male threads



1. Using a pipe cutter for PERTAL pipes or a pipe roller cutter, cut the pipe perpendicularly to its axis at the required length.
2. Give the pipe its desired shape. Bend the pipe using an inner or outer spring. Observe the minimum radius $R > 5 De$ requirement. When using mechanic pipe benders for diameters 16–20 mm, the minimum radius is $R > 3,5 De$. Execute all bends at a distance of $10 \times De$ from the nearest joint.
3. Calibrate the pipe and chamfer its inner edge using a calibrator. The aluminum layer should remain intact. The edge of the pipe must not have any chips or splinters.
4. Slide the nut onto the pipe. Slide the stub of the fitting into the pipe until it clearly stops. The depth of the joint is c.a. 9 mm for pipes of 16, 20 mm in diameter and 12 mm for pipes of 25 (26) mm in diameter.
5. Slide the fitting and the pipe into the socket of the male fitting until it clearly stops.
6. Screw the nut on the fitting using a wrench.

! Particular attention should be paid to the precise placement of the fitting in the socket and tightening the nut. When modernizing an installation, it is possible to disassemble the joint (cut off the used pipe ending). There is, however, no possibility of reusing the inlet connection. Do not place such joints in flooring screeds. They must be located in easily accessible places.

Eurocone adapters

Fittings of this type are made of brass or brass and PPSU. Each fitting consists of a body with a stub equipped with an O-Ring (used for mounting pipe ends), a compression ring and a threaded nut. Such fittings are compatible with KAN-therm brass fittings with male threads, such as elbows, tees, tap connections (9012 series) with specially formed sockets.



1. Eurocone adapter with compression ring for PERT, PEXC and bluePERT pipes.
2. Universal brass Eurocone adapter with compression ring for KAN-therm system pipes.
3. PPSU universal eurocone adapter for KAN-therm pipes.

Mounting the pipe on the stub is performed in an identical way as in the case of the threaded joint (inlet connection) described above. Remember to slide on the compression ring after applying the nut. Then, remember to move the ring towards the edge of the pipe before screwing in the nut.

i **When modernizing an installation, it is possible to disassemble the joint (cut off the used pipe ending). There is also a possibility of reusing the eurocone adapter (provided that the ring is replaced with a new one).**

All above mentioned eurocone adapters are compatible with:

- a series of KAN-therm fittings with male threads equipped with Eurocone sockets,
- KAN-therm manifolds equipped with special 1/2" and 3/4" nipples.

To connect 16 × 2 mm PERTAL pipes directly to the manifold body (without nipples), use a pressed fitting with a compression ring with 1/2" male thread. The thread is equipped with an O-Ring, making additional sealants redundant.



Fitting with 1/2" male thread for connecting of 16 × 2 pipes to manifolds.

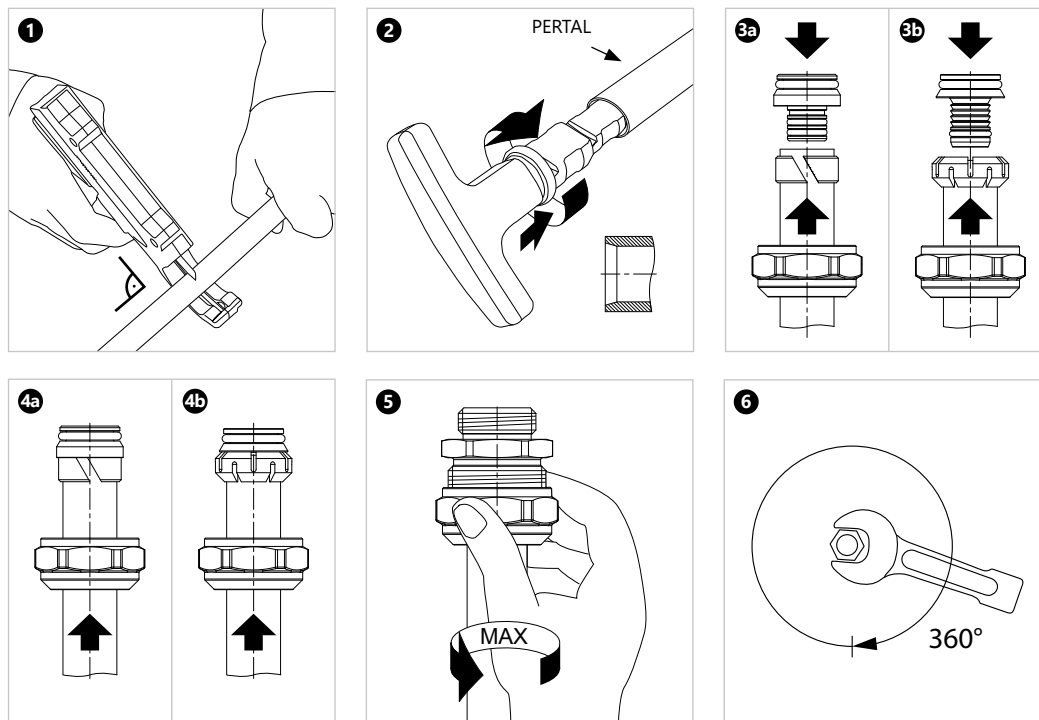

4 Transport and storage

The elements of KAN-therm ultraPRESS system can be stored in temperatures below 0 °C. If that is a case, secure them against dynamic loads.

They should be protected against mechanical damage during transport. Due to the sensitivity to ultraviolet rays, the pipes should be protected against direct long-term exposure to sunlight, both during storage, transport and assembly. KAN-therm ultraPRESS system elements should be transported by covered means of transport and stored in standard storage facilities in conditions which do not cause deterioration of their quality.

- Do not store in the immediate vicinity of chemicals and sources of ammonia (toilets),
- Do not expose to sunlight (protect from heat and UV radiation),
- Avoid storing near strong heat sources,
- During storage and transport, no contact with sharp objects is allowed,
- Avoid surfaces with sharp edges or loose sharp elements on their surface,
- Do not drag directly on the ground or concrete surface,
- Protect against dirt, mortar, oils, greases, paints, solvents, moisture chemicals, etc.,
- Store and transport in original packaging,
- Remove elements from their original packaging immediately before assembly,
- If it is necessary to cut into insulation already fitted to a pipe (e.g. to fit it around a pipe fitting), take particular care not to damage the surface of the pipe. Use only suitable, sharp tools for cutting, which allow you to make a precise cut through the insulation layer without damaging the pipe material.



Detailed information about storage and transport of components can be found at en.kan-therm.com.



**KAN-therm
MULTISYSTEM**

> 35 | years of experience
on the installation
market

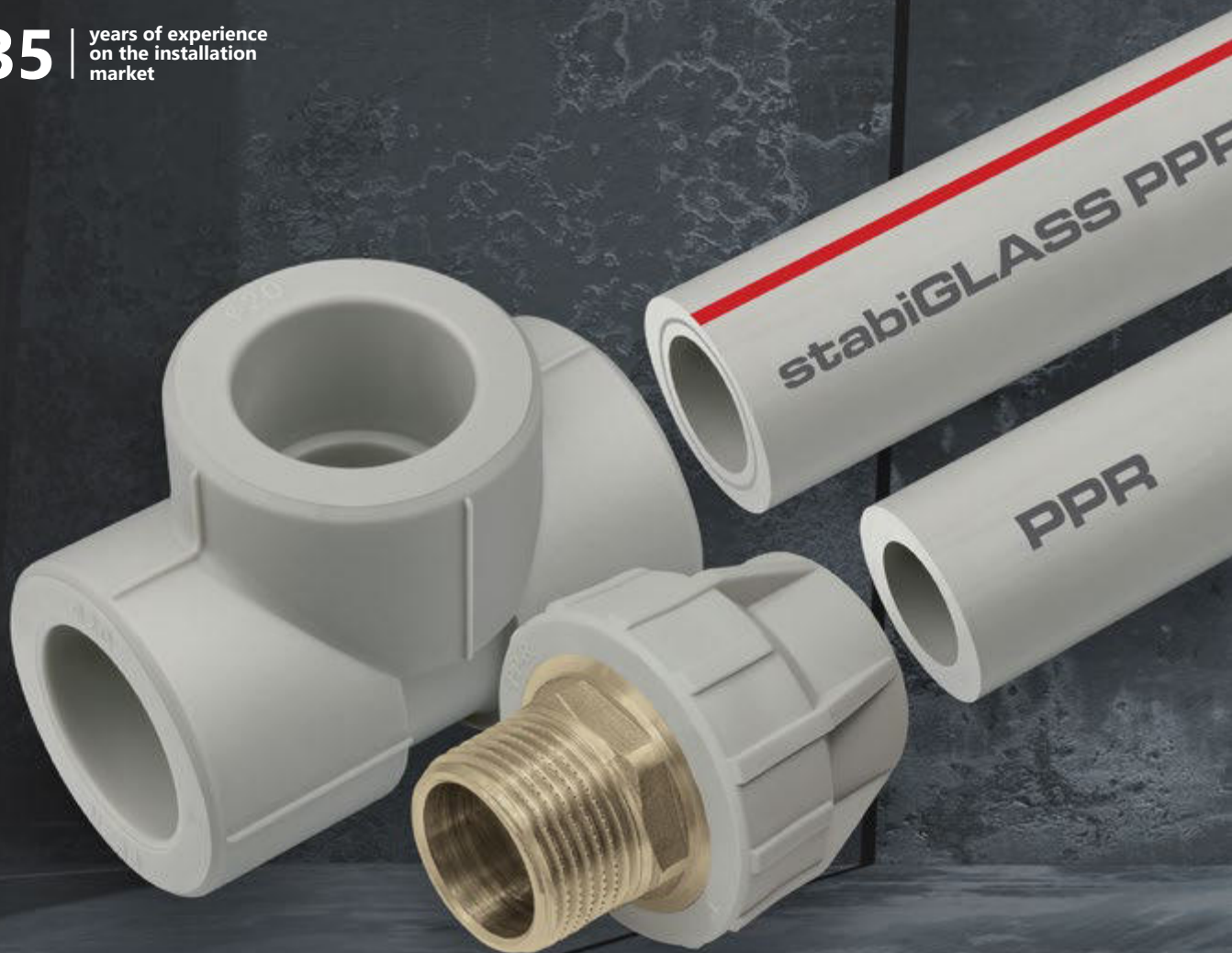

KAN-therm
PP

**HIGH QUALITY WITH
REASONABLE PRICE**

Install the **future**

SYSTEM KAN-therm PP

1	General information	71
2	KAN-therm PP pipes	72
2.1	Physical properties of KAN-therm PP pipe material	73
2.2	Pipe marking, color	73
2.3	Dimension parameters of KAN-therm PP pipes	74
3	Fittings and other elements of the system	75
4	Scope of use	76
5	Technique of connecting KAN-therm PP installations – welded joints	78
5.1	Tools – preparation of the welder	79
5.2	Preparation of elements for welding	80
5.3	Welding technique	81
5.4	Fittings with metal threads and collars	82
6	Transport and storage	84

SYSTEM KAN-therm PP

1 General information

KAN-therm PP is a complete installation system consisting of pipes and fittings made of polypropylene PP-R (type 3), a thermoplastic material, with diameter range: 16–110 mm. Connecting elements is performed using the socket welding technique (thermal polyfusion) and electric welders. This welding technique creates continually uniform joints and therefore guarantees exceptional tightness and mechanic durability of the installation. The system is designed for indoor water supply installations (hot and cold potable water), heating installations and technological installations.

The KAN-therm PP system is characterized by:

- high hygiene of all products (physiological and microbiological neutrality),
- high chemical resistance,
- resistance to material corrosion,
- low thermal conductivity (high thermal isolation of pipes),
- low specific weight,
- resistance to scaling,
- muffling vibrations and noises,
- mechanic durability,
- uniform joints,
- high usage durability.

2 KAN-therm PP pipes

KAN-therm PP pipes and fittings are manufactured of high quality PP-R polypropylene (random copolymer of polypropylene), formerly marked as polypropylene type 3.

In terms of structure, we differentiate these types of pipes: uniform and multilayer pipes: reinforced with a layer of glass fiber, the so-called stabiGLASS PPR pipes.

PP-RCT makes it possible for designers to select pipes with thinner walls and in some cases also smaller diameter pipes.

KAN-therm PP stabiGLASS PPR pipes also feature multilayer structure. Their internal layer, which is reinforced with glass fibre (40% of pipe wall thickness) determines very high durability of the pipe and its low thermal elongation $\alpha=(0,05 \text{ mm/m} \times K)$.

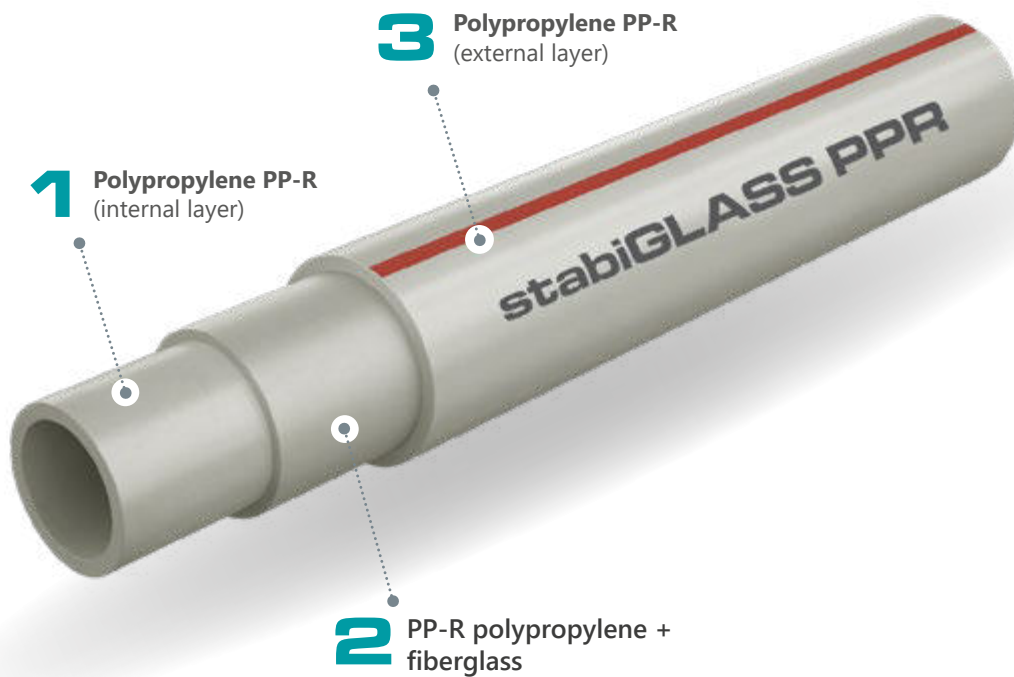

Structure of a stabiGLASS PPR

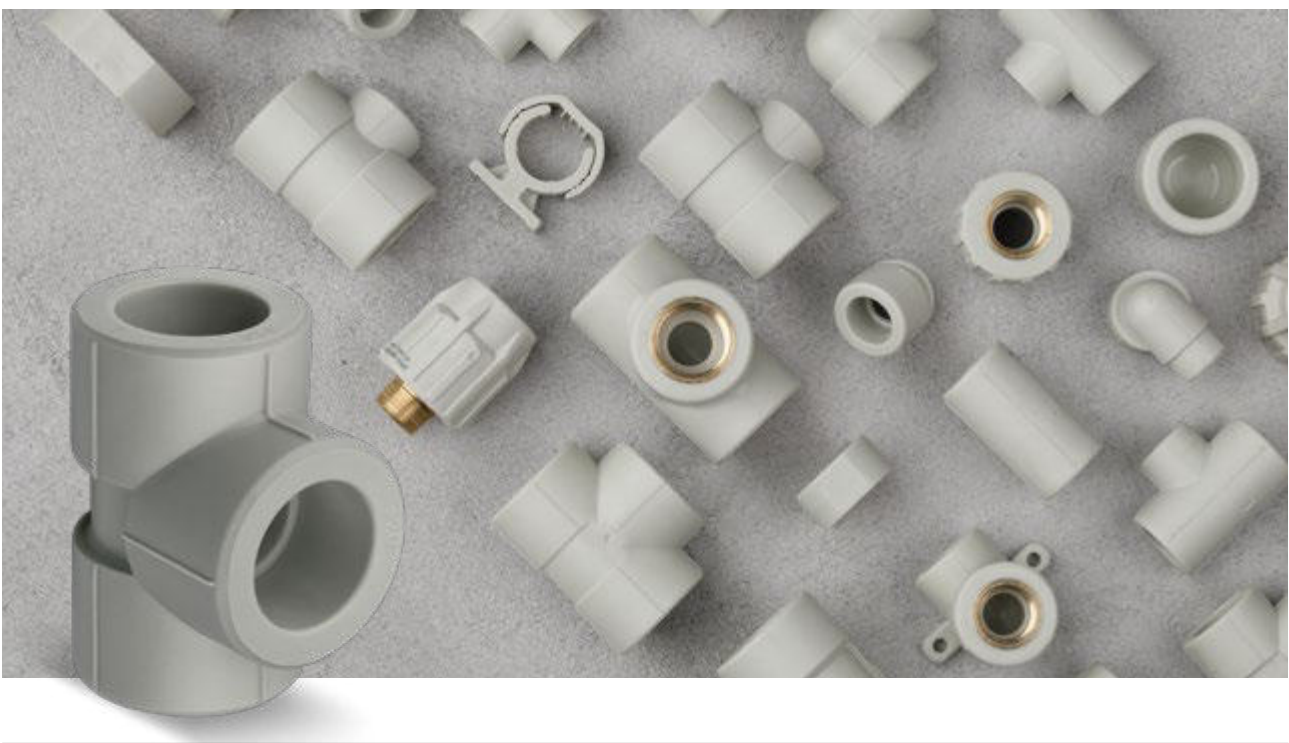

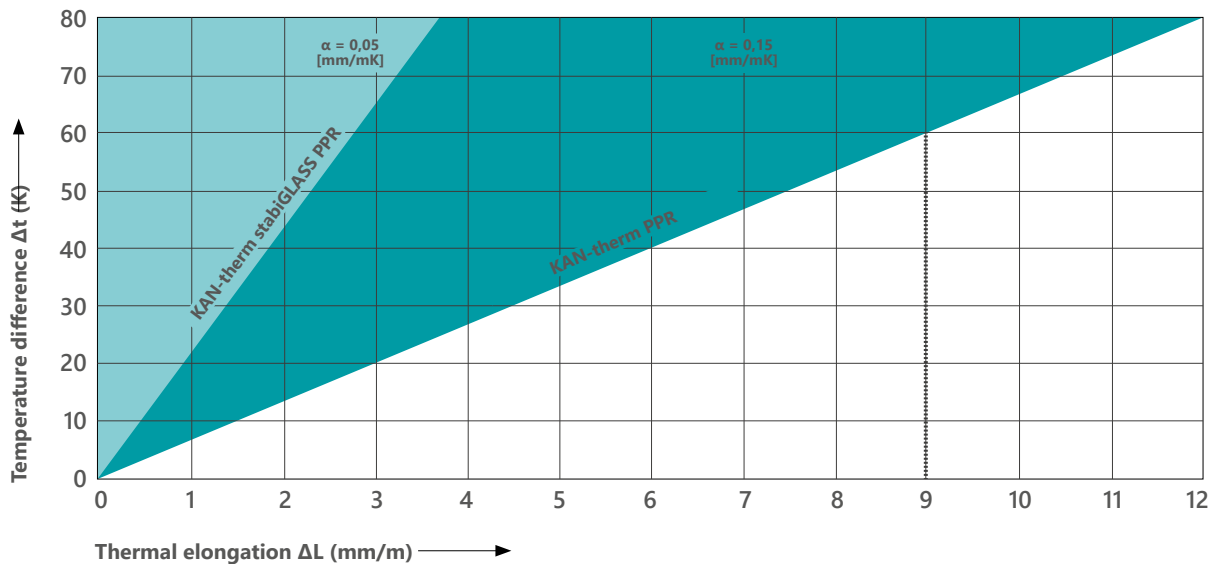

Comparison of the thermal expansion factor in uniform PPR and stabiGLASS PPR pipes.

2.1 Physical properties of KAN-therm PP pipe material

Property	Symbol	Unit	Value
			PPR
linear elongation coefficient	α	mm/m \times K	0,15 for uniform pipes 0,05 for stabiGLASS PPR pipes
thermal conductivity	λ	W/m \times K	0,24
density	ρ	g/cm ³	0,90
elasticity module		N/mm ²	900
minimum bend radius	R_{min}	mm	8 x Dz (for diameters 16-32)
internal wall roughness	k	mm	0,007

2.2 Pipe marking, color

Our pipes are marked in a continuous manner with inscriptions with a 1-meter span, containing i. e. the following indications:

Marking description	Example of marking
Name of manufacturer and/or trademark:	KAN, KAN-therm
Nominal external diameter x wall thickness	16 x 2,7
Dimension class	A
Pipe structure (material)	PP-R
Pipe code	04000316
Number of Standard or Technical Certificate	PN-EN 15874
Pressure/dimension ratio	PN20 SDR6
Application class/es with design pressure	Class 1/10 bar – 2/8 bar – 4/10 bar – 5/6 bar
Date of production	18.08.09
Other manufacturer markings, e.g. running meter, batch number	045 m



Notice – other, additional markings, e.g. numbers of certificates may also be inscribed on the pipe.

Pipe color: gray;

Pipe surface: mat stabiGLASS PPR pipes are gray with a red stripe.

Pipes are supplied 4 m long bars.

2.3 Dimension parameters of KAN-therm PP pipes

KAN-therm PP system offers some types of pipes, differing in terms of wall thickness and structures (compound pipes):

PPR PN16 pipes	(20–110 mm)
PPR PN20 pipes	(16–110 mm)
stabiGLASS PPR PN16 pipes	(20–110 mm)
stabiGLASS PPR PN20 pipes	(20–110 mm)



KAN-therm PP PPR PN16 pipes (S3,2/SDR7,4)

Size [mm]	External diameter D [mm]	Wall thickness s [mm]	Internal diameter d [mm]	Capacity by unit [l/m]	Weight by unit [kg/m]
20 × 2,8	20	2,8	14,4	0,163	0,148
25 × 3,5	25	3,5	18,0	0,254	0,230
32 × 4,4	32	4,4	23,2	0,415	0,370
40 × 5,5	40	5,5	29,0	0,615	0,575
50 × 6,9	50	6,9	36,2	1,029	0,896
63 × 8,6	63	8,6	45,8	1,633	1,410
75 × 10,3	75	10,3	54,4	2,307	2,010
90 × 12,3	90	12,3	65,4	3,358	2,870
110 × 15,1	110	15,1	79,8	4,999	4,300

KAN-therm PP PPR PN20 pipes (S2,5/SDR6)

Size [mm]	External diameter D [mm]	Wall thickness s [mm]	Internal diameter d [mm]	Capacity by unit [l/m]	Weight by unit [kg/m]
16 × 2,7	16	2,7	10,6	0,088	0,110
20 × 3,4	20	3,4	13,2	0,137	0,172
25 × 4,2	25	4,2	16,6	0,216	0,266
32 × 5,4	32	5,4	21,2	0,353	0,434
40 × 6,7	40	6,7	26,6	0,556	0,671
50 × 8,3	50	8,3	33,4	0,866	1,050
63 × 10,5	63	10,5	42,0	1,385	1,650
75 × 12,5	75	12,5	50,0	1,963	2,340
90 × 15,0	90	15,0	60,0	2,827	3,360
110 × 18,3	110	18,3	73,4	4,208	5,040

KAN-therm PP stabiGLASS PPR PN16 (S3,2/SDR7,4) pipes

Size [mm]	External diameter D [mm]	Wall thickness s [mm]	Internal diameter d [mm]	Capacity by unit [l/m]	Weight by unit [kg/m]
20 × 2,8	20	2,8	14,4	0,163	0,160
25 × 3,5	25	3,5	18,0	0,254	0,250
32 × 4,4	32	4,4	23,2	0,415	0,430
40 × 5,5	40	5,5	29,0	0,615	0,650
50 × 6,9	50	6,9	36,2	1,029	1,000
63 × 8,6	63	8,6	45,8	1,633	1,520
75 × 10,3	75	10,3	54,4	2,307	2,200
90 × 12,3	90	12,3	65,4	3,358	3,110
110 × 15,1	110	15,1	79,8	4,999	4,610

KAN-therm PP stabiGLASS PPR PN20 (S2,5/SDR6)

Size [mm]	External diameter D [mm]	Wall thickness s [mm]	Internal diameter d [mm]	Capacity by unit [l/m]	Weight by unit [kg/m]
20 x 3,4	20	3,4	13,2	0,137	0,218
25 x 4,2	25	4,2	16,6	0,216	0,328
32 x 5,4	32	5,4	21,2	0,353	0,520
40 x 6,7	40	6,7	26,6	0,556	0,770
50 x 8,3	50	8,3	33,4	0,866	1,159
63 x 10,5	63	10,5	42,0	1,385	1,770
75 x 12,5	75	12,5	50,0	1,963	2,780
90 x 15,0	90	15,0	60,0	2,830	3,590
110 x 18,3	110	18,3	73,4	4,210	5,340

Explanation of markings of uniform PPR pipes

S	dimension series according to ISO 4	$S = (D-s)/2s$
SDR	Standard Dimension Ratio	$SDR = 2 \times S + 1 = D/s$
D(dn)	nominal external pipe diameter	
s(en)	nominal wall thickness	in brackets: markings acc. to standard
PN	Pressure nominal	

S	SDR	PN
5	11	10
3,2	7,4	16
2,5	6	20

3 Fittings and other elements of the system

The basic method of executing joints in polypropylene installations is thermal welding which, thanks to the use of proper fittings, allows connecting pipes (pipe couplings), closing the pipeline (end caps), redirecting the pipeline (elbows, bends, passing loops, tees), changing the diameter of the pipe (couplings and reducers), executing branch-offs (tees, four-ways), connecting devices and fixtures (collar joints and metal threaded joints). Ball valves with polypropylene couplings serve as the joints here.

All of the above mentioned elements allow connecting fittings to pipes or connecting two or more pipe sections, forming inseparable joints, requiring the pipe to be cut off if there is a need for disassembling the fitting. In order to execute a separated joint, sleeves for collar joints and union adapters must be used. All joints are universal and may be used with all types of KAN-therm PP pipes, irrespective of their wall thickness or structure.

All of the KAN-therm PP system fittings are designed in PN20 pressure rating.

KAN-therm PP system, apart from pipes, consists of the following elements:

- fittings (uniform) made of PP-R polypropylene (couplings, reducers, elbows, nipple elbows, tees),
- couplings with female and male metal threads ½" – 3" – used for connecting to devices and fixtures,
- sleeves for collar joints with loose collars, union adapters – for detachable joints,
- expansion bends, mounting plates, ball valves,
- mounting elements – plastic or metal with rubber insert clamps,
- tools for pipe bending, treatment and welding.

4 Scope of use

Thanks to the properties of PP-R and PP-RCT material, the KAN-therm PP installation system has a wide spectrum of applications:

- cold (20 °C/1,0 MPa) and hot (60 °C/1,0 MPa) water installations in housing buildings, hospitals, hotels, office buildings, schools,
- central heating installations (temp. up to 90 °C, working pressure up to 0,8 MPa),
- compressed air installations,
- balneology installations,
- installations in agriculture and horticulture,
- pipelines in the industry, e.g. for transporting aggressive media and food products,
- ship installations.

The scope of use assumes new installations, as well as repairs, modernization and exchange projects.

Thanks to special properties of polypropylene (physiological and microbiological neutrality, resistance to corrosion, resistance to scaling, immunity to vibrations, very good thermal insulation of pipes), KAN-therm PP system installations are widely used, particularly in water supply installations, when mounting water supply risers and installation levels. This refers to both hot and cold tap water installations in housing buildings, hospitals, hotels, office buildings, schools, on ships, etc.



KAN-therm PP installations

KAN-therm PP installations are irreplaceable when replacing old, corroded water supply installations. They are also used in renovations of old heating installations.

Pipes and joints in the KAN-therm PP system are in full compliance with applicable standards, which guarantees their long-term and reliable operation as well as full security of assembly and use of the installation.

Certificates and technical approvals are available at www.kan-therm.com.

The operational parameters and scopes of use of KAN-therm PP pipe installations in heating and water supply installations are presented in the table.

Application (acc. to ISO 10508)	Total time of exploitation, years	Time of operation years/hours	Operating temperature T °C	PPR	
				SDR6 (S2,5), SDR6 (S2,5) stabiGLASS	SDR7,4 (S3,2), SDR7,4 (S3,2) stabiGLASS
				Maximum operating pressure (bar)	
Hot domestic water [application class 1] $T_d / T_{max} = 60/80$ °C	50	49	60	10	8
		1	80		
	Time of operation at Tkr	100 hours	95		
Hot domestic water [application class 2] $T_d / T_{max} = 70/80$ °C	50	49	70	8	6
		1	80		
	Time of operation at Tkr	100 hours	95		
Radiant heating, low temperature radiator heating [application class 4] $T_d / T_{max} = 60/70$ °C	50	2,5	20	10	10
		20	40		
		25	60		
		2,5	70		
	Time of operation at Tkr	100 hours	100		
Radiator heating [application class 5] $T_d / T_{max} = 80/90$ °C	50	14	20	6	6
		25	60		
		10	80		
		1	90		
	Time of operation at Tkr	100 hours	100		

Maximal operating pressure of PPR pipes depending on the temperature and service life of the installation (safety factor C = 1,5)

Temperature [°C]	Time [years]	PPR pipes	
		PN16 / SDR7,4 / S3,2	PN20 / SDR6 / S2,5
10	1	27,6	35,4
	5	26	33,3
	10	25,4	32,5
	25	24,5	31,4
	50	23,9	30,6
20	1	23,6	30,2
	5	22,2	28,4
	10	21,6	27,6
	25	20,8	26,7
	50	20,3	26
40	1	17	21,8
	5	15,9	20,4
	10	15,5	19,8
	25	14,9	19
	50	14,5	18,5
60	1	12,2	15,6
	5	11,3	14,5
	10	11	14
	25	10,5	13,4
	50	10,2	13

Temperature [°C]	Time [years]	PPR pipes	
		PN16 / SDR7,4 / S3,2	PN20 / SDR6 / S2,5
70	1	10,2	13,1
	5	9,5	12,1
	10	9,2	11,7
	25	8	10,2
	50	6,7	8,6
80	1	8,6	11
	5	7,6	9,7
	10	6,4	8,2
	25	5,1	6,6
	50	4,3	5,6
90	1	7,2	9,2
	5	5	6,4
	10	4,2	5,4
	25	3,4	4,3
95	1	6,1	7,8
	5	4,1	5,3
	10	3,5	4,4



Note

Conditions of using the KAN-therm PP system in installations other than heating and water supply installations - chemical resistance.

Elements of the KAN-therm PP system are characterized by high chemical resistance. You should remember, however, that the chemical resistance feature of polypropylene depends on the type and concentration of substances, as well as other factors, e.g. temperature and pressure of the medium, and ambient temperature. Chemical resistance of the couplings inserts (metal) must not be compared to the resistance of PP-R elements. Due to this fact, transition couplings are not applicable for all industrial usages. Before deciding on the application of KAN-therm PP pipes and joints in installations conducting substances different than water, please contact the KAN's Technical Department.

5 Technique of connecting KAN-therm PP installations – welded joints

Welding is the basic technology used for connecting KAN-therm PP polypropylene pipelines. The welding process is based on plasticizing the elements to be connected under high temperature (to a certain depth), and then joining, under right pressure, the plasticized layers and, finally, cooling the entire area to a temperature of hardening.

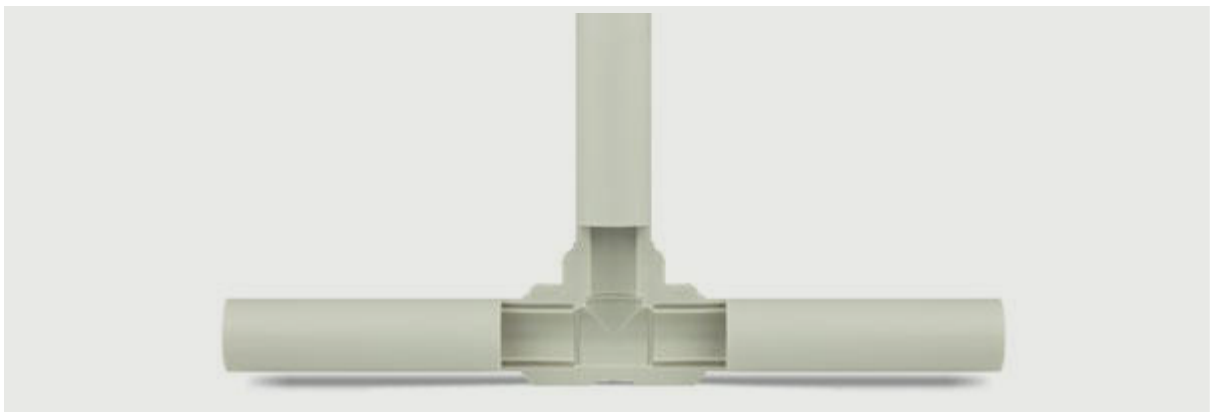

Cross-section of a welded joint



KAN-therm PP tools

Plasticization of layers to be connected takes place at 260 °C in a temporal function, taking into account the need to warm up a layer of material (external surface of the pipe and internal surface of the coupling) and a required depth. The essence of the process of welding polypropylene, also called thermal polyfusion, is relocating and mixing the polymer chains of plasticized and then pressed layers of elements being connected. Maintaining proper conditions in this process (temperature, time, pressure force and area, cleanness of elements being connected) guarantees proper execution of the joint and its durability.

The process of heating (plasticizing) takes place with the use of an electric welder equipped with a heating plate with exchangeable (for each diameter) heating inserts covered with Teflon.

Depending on the diameter of the pipe, heating takes from 5 to 50 seconds. After this time, heated elements are removed from the inserts and the pipe is immediately mounted (without rotation!) inside the coupling at a depth which must be marked earlier. It is then that the particles of both elements penetrate one another and mix. A joint formed through thermal welding has impressive mechanic durability, exceeding the durability of the pipe itself (the cross section of the joint exceeds the cross section of the pipe).

5.1 Tools – preparation of the welder

In order to execute a polypropylene joint, use a welder designed to work under 230 V. This device consists of a power supply cable (1), a grip (2) with an in-built thermostat and controls (diodes) (3) and a heating plate (4), which heating inserts (6) are mounted to. The power of KAN-therm welders is 800 or 1600 W.

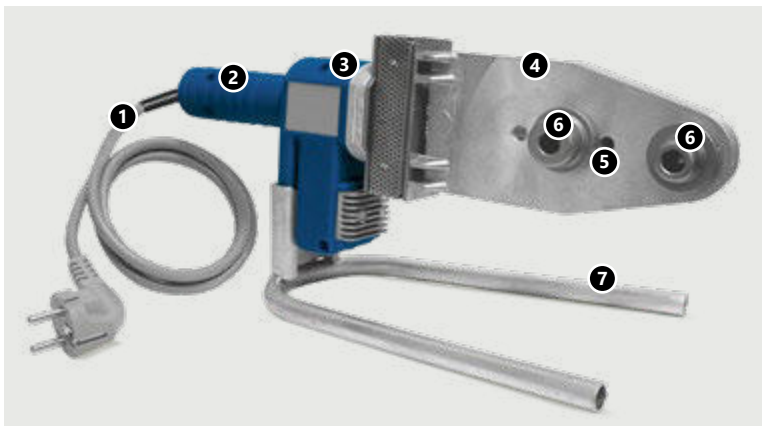

- Welder elements
1. Power supply cable
 2. Welder grip
 3. Power supply and thermostat controls
 4. Heating plate
 5. Openings in the heating plate
 6. Heating inserts
 7. Stand



Welding temperature 260 °C

- Before starting any works, read the instruction manual to the corresponding welder type.
- Heating inserts (coupling and heating rod) must be screwed tightly using a wrench included in the set. They must contact the surface of the heating plate tightly. The inserts must not extend over the edge of the heating plate.
- Secure the inserts against scratching or polluting. Clean all pollutions with a natural cloth and rubbing alcohol.
- Connection to power supply is signaled by the lamp or diode on the casing lighting up.
- The required welding temperature (on the surface of inserts) is 260 °C. The temperature of the heating plate is higher (280-300 °C). When the device reaches the correct welding temperature, a thermostat control most often (depends on the model of the welder) signals it.

- After finishing all works, disconnect the welder from power supply and leave it to cool down. Do not cool the welder rapidly, e.g. using cold water, since this may lead to the damage of heating circuits.
- Do not use a power supply cable of small cross section or one which is too long. Voltage fluctuations might disturb the proper operation of the device.
- Do not use the power supply cable to transport or hang the welder. When out of work, place it on the stand included in the set.



NOTICE

Due to varying tolerances of pipes and fittings by other manufacturers, to ensure the execution of a sealed and durable joint, we suggest the use of original tools, particularly heating inserts, as offered within the KAN-therm PP system.



Tools – work safety

All tools must be used according to their dedication and the manufacturer's instruction manual. During the use of tools, one must observe the terms of regular inspections and all applicable safety regulations. Using tools against their designed use may lead to their damage or to the damage of their accessories. It may also lead to the occurrence of leakages in installation joints.

5.2 Preparation of elements for welding



1. Cutting the pipe.

Use a pipe cutter, (or for bigger diameters) a round pipe cutter or a mechanic saw with a blade adapted to cutting polypropylene to cut the pipe. When cutting the pipe with a saw, remove all remainings from the surface and from the interior of the pipe.

2. Marking the depth of the weld.

Mark (using a ruler or, a template and a pencil) the depth of the weld at the end of the pipe (PPR, PPRCT and stabiGLASS PPR pipes). Insufficient welding depth may weaken the joint. On the other hand, if the pipe is mounted too deep, it may become narrower (flange). The depths of welds are provided in the table.

Welding parameters

External pipe diameter [mm]	Welding depth [mm]	Heating time [sek]	Binding time [sek]	Cooling time [min]
16	13,0	5	4	2
20	14,0	5	4	2
25	15,0	7	4	2
32	16,0	8	6	4
40	18,0	12	6	4
50	20,0	18	6	4
63	24,0	24	8	6
75	26,0	30	10	8
90	29,0	40	10	8
110	32,5	50	10	8



Notice

The time of heating in ambient temperatures below +5 °C should be increased by 50%.

5.3 Welding technique



3. Heating the pipe and the joint.

The surfaces to be heated must be clean and dry. Slide the pipe end (without rotation) into the heating sleeve, up to the marked depth of the weld. At the same time, slide the fitting (also without rotation) on the heating rod, until it stops. Start counting the heating time when the pipe and the fitting are mounted at their entire welding depths. After the lapse of a half of the heating time (according to the table), continue to heat the fitting and start heating the pipe, until the end of required heating time.

4. Connecting elements.

After heating take the pipe and fitting out of heating inserts in a continuous manner and immediately, without rotating, connect them. The marked welding border should then be covered by outflowing excess material. Do not heat beyond the marked welding border, since it could result in a narrowing or even a clog in the joint. When connecting elements, the joint can be slightly adjusted on the axis (up to a few degrees). Rotating elements being connected is absolutely prohibited.



5. Stabilizing and cooling.

After the welding time has lapsed, the joint must be stabilized and cooling must be initiated (time of cooling is provided in the table). In this period, you must not apply any mechanic pressure on the pipe. After all joints have cooled down, connect the installation to water supply and conduct a pressure test.

5.4 Fittings with metal threads and collars

Apart from welded joints, KAN-therm PP offers threaded and collar joints.



KAN-therm PP fittings with brass threads

The most basic elements with metal threads are PP-R polypropylene fittings (couplings, elbows, tees) with brass “inserts” with male and female threads. They form inseparable joints. Unscrewing a joint like this requires the pipe to be cut off. Such joints are used for connecting installations to heating and water supply devices and fixtures. Joints with 1” and bigger female and male threads are equipped with a six-sided mount for a flat wrench, allowing devices to be screwed-in and – out without applying excessive pressure on the weld and the fitting itself.

The group of detachable joints, allowing performance of multiple, exchangeable connections, includes KAN-therm PP union adapters (used e.g. to connect water meters) and “half unions” with specially formed stubs (for mounting rubber seals) and metal nuts.



KAN-therm PP detachable fittings – male union adapter, female union adapter, half-union and union

KAN-therm PP also offers double union adapters (with two PP-R couplings) which allow mounting flanges on the pipe. An additional coupling with internal diameter corresponding to the external diameter of the pipe is required to connect these joints with the pipe.

For large pipe diameters, use flange couplings to execute detachable joints. Flange couplings are used e.g. to connect devices to flange stubs (pumps, valves, water meters). In installations, KAN-therm PP adapters are used with loose flanges.

It is necessary to assemble a separate, flat seal. The seal should be made of a material type suitable for the parameters of the medium running through the joint. The connection between flange adapter and pipe is done with a utilization of muff coupling or by other fitting.



Ø110 mm flange joint

Flanges

Sleeve size	DN	D	d1	k	d0	q	N
Ø40	32	140	43	100	18	18	4
Ø50	40	150	53	110	18	18	4
Ø63	50	165	66	125	18	20	4
Ø75	65	185	78	145	18	20	8
Ø90	80	200	95	160	18	20	8
Ø110	100	220	114	180	18	22	8

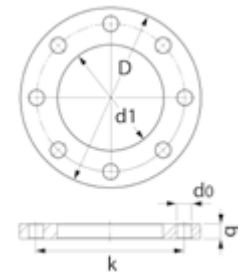

N - number of bolt holes

KAN-therm PP offers a wide selection of shut-off valves and fixtures welded onto pipelines:



- ball valves,
- shut-off globe valves,
- globe valves for flush assembly.

6 Transport and storage

- Store and transport pipes in horizontal position, preventing them from bending,



- Maximum storage height – 1,2 m,

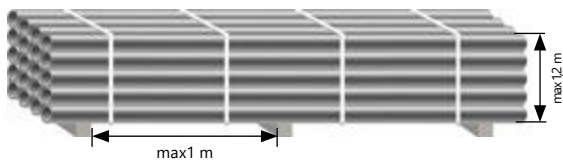

- During storage, pipes and joints must not be exposed to sun rays (they must be protected against heat and UV rays),



- Store pipes away from sources of strong heat,



- Protect pipes against shocks or mechanic impacts, particularly their endings. Do not throw or drag pipes during transport,



- Do not use damaged (chipped, cracked, etc.) pipes.



- Be extra careful when transporting or carrying pipes in temperatures below 0 °C (in these conditions pipes are more vulnerable to mechanic damages, especially stabiGLASS PPR pipes),
- Perform assembly at temperatures above +5 °C. If it is necessary to install at temperatures lower than recommended, read the specific recommendations for the installation of the KAN-therm PP system at temperatures below 0 °C and absolutely use increased heating times for pipes and fittings,

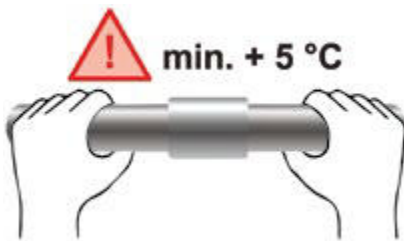

- Protect pipes and fittings against polluting (particularly with oil or grease),
- Protect pipes and joints from the access of chemical substances (e.g. paint or organic solvents, steam containing chlorine).



Detailed information about storage and transport of components can be found at en.kan-therm.com.



**KAN-therm
MULTISYSTEM**

> 35 | years of experience
on the installation
market



KAN-therm

Steel & Inox

TRADITIONAL MATERIAL
IN MODERN TECHNOLOGY

Ø 12–108 mm

PRESTIGIOUS MATERIAL,
GIGA POSSIBILITIES

Ø 12–168,3 mm

SYSTEM **KAN-therm Steel** / **KAN-therm Inox**

1	General information	89
2	System KAN-therm Steel	90
2.1	Pipes and fittings – characteristics	90
2.2	Pipe diameters, lengths, weight and capacity	90
2.3	Scope of use	91
3	System KAN-therm Inox	92
3.1	Pipes and fittings – characteristics	92
3.2	Pipe diameters, lengths, weight and capacity	92
3.3	Scope of use	93
4	Sealants – O-Rings	94
5	Durability, resistance to corrosion	95
5.1	Internal corrosion	96
5.2	External corrosion	98
6	Technique of Press joints	99
6.1	Tools	99
6.2	Preparation of pipes for pressing	106
6.3	Pipe bending	112
6.4	Threaded fittings, connecting with other KAN-therm systems	112
7	Flange connections	113
8	Ball valves of KAN-therm Steel and KAN-therm Inox systems	114
8.1	Service and maintenance	115
9	Operational notes	115
9.1	Equipotential bonding	115
10	Transport and storage	116

SYSTEM **KAN-therm Steel** / **KAN-therm Inox**

1 **General information**

KAN-therm Steel and Inox are complete, state-of-the-art installation systems consisting of precise pipes and fittings manufactured out of high quality carbon steel (coated with an anti-corrosive zinc layer) – KAN-therm Steel and or stainless steel – KAN-therm Inox. Assembly of these installations bases on the "Press" technique, in which fittings are radially pressed over the pipe. Special pressure seals (O-Rings) provide tightness of joints. O-Rings are made of high quality synthetic rubber resistant to high temperatures. A three-point type "M" pressing system, which guarantees reliable, uninterrupted operation of the system. Steel and Inox systems are used in indoor installations (new and renovated) in housing estates, public buildings and industrial facilities.

KAN-therm Steel and Inox systems are characterized by:

- easy and quick assembly, without the use of open flame,
- large scope of diameters of pipes and fittings, from 12 to 108 mm (168,3 for Inox pipes),
- broad working temperature tolerance: from -35 °C to 135 °C (200 °C after exchanging standard seals),
- resistance to high pressure, up to 25 bar (for water-filled installations),
- low flow resistance in pipes and fittings,
- possibility of connecting with plastic KAN-therm systems,
- low weight of pipes and fittings,
- resistance to mechanical loads,
- no fire threat during assembly and use (reaction to fire class A),
- esthetic value of installations,
- signaling of mistakenly not-pressed joints in the installation.

2 System KAN-therm Steel

2.1 Pipes and fittings – characteristics

Pipes (precise, thin-walled, with longitudinal seam) and fittings are made of low-carbon (RSt 34-2) steel, material no. 1.0034 according to PN-EN 10305-3. Outer surface of the pipe is coated with a layer of zinc (Fe/Zn 88), 8-15 µm thick and additionally secured with a passivating layer of chromium. Zinc is applied through hot dip galvanization, which guarantees ideal adhesion to the wall, also during pipe bending. For transport and storage, pipes are additionally thermally coated on the inside and outside with a layer of oil. Fittings are offered with pressed ends and O-Ring seals, or with pressed and threaded ends with female or male threads, according to PN-EN 10226-1.

Physical properties of KAN-therm Steel pipes

Property	Symbol	Unit	Value	Remarks
Linear elongation coefficient	α	mm/m × K	0,0108	$\Delta t = 1 \text{ K}$
Thermal conductivity	λ	W/m × K	58	
Minimal bending radius	R_{\min}		$3,5 \times D_e$	max. diameter 28 mm
Internal wall roughness	k	mm	0,01	

2.2 Pipe diameters, lengths, weight and capacity

Scope of diameters Ø12 to Ø108 mm, for wall thickness from 1,2 to 2 mm.

Pipe length 6 m ± 50 mm, end-capped.

Dimensions, weight by unit, water capacity of KAN-therm Steel pipes

DN	External diameter × Wall thickness	Internal diameter	Weight by unit	Capacity by unit
	mm × mm	mm × mm	kg/m	l/m
10	12 × 1,2	9,6	0,320	0,072
12	15 × 1,2	12,6	0,409	0,125
15	18 × 1,2	15,6	0,498	0,192
20	22 × 1,5	19,0	0,759	0,284
25	28 × 1,5	25,0	0,982	0,491
32	35 × 1,5	32,0	1,241	0,804
40	42 × 1,5	39,0	1,500	1,194
50	54 × 1,5	51,0	1,945	2,042
	66,7 × 1,5	63,7	2,412	3,187
65	76,1 × 2,0	72,1	3,659	4,080
80	88,9 × 2,0	84,9	4,292	5,660
100	108 × 2,0	104,0	5,235	8,490

2.3 Scope of use

- closed heating installations (new installations and renovations),
- closed chilled water installations (notice – see chapter Internal corrosion),
- closed technological heat installations,
- closed solar installations (Viton O-Rings) (notice – see chapter External corrosion),
- fuel oil installations (Viton O-Rings),
- compressed air installations (details in 'compressed air installations in KAN-therm system').

The operating parameters of heating systems for the KAN-therm Steel system are specified in the ITB National Technical Assessment

- permissible operating pressure up to 25 bar, medium: water, operating temperature 135 °C, diameter range 12–54 mm, using Novopress pressing tools fitted with jaws and slings with the "M" profile (diameters 12–28 mm) and "HP" profile (diameters 35–54 mm).
- maximum working pressure up to 16 bar, medium: water, working temperature 135 °C, diameter range 12–108 mm, using standard press tools with an "M" profile.



Notice: Working pressure of 25 bar does not include KAN-therm Steel and KAN-therm Inox ball valves and axial compensators.

Working pressure of 25 bar includes installations filled with water. If using other liquids, contact KAN Technical Support Department.

Test pressure can not exceed 25 bar during pressure tightness test.

Maximum working temperature (without temporal limitations) is 135 °C. When using Viton O-Rings, working temperature may be increased to 200 °C (parameters and scopes of use of Viton O-Rings are presented in chapter Sealings – O-Rings).



Examples of KAN-therm Steel installations

3 System KAN-therm Inox

3.1 Pipes and fittings – characteristics

Pipes (precise, thin-walled with longitudinal seam out of) are made of thin-walled alloy steel, chromium-nickel-molybdenum X5CrNiMo 17 12 2 No. 1.4401, AISI 316 or X2CrNiMo 17 12 2 No. 1.4404, AISI 316L or X2CrMoTi18-2 No. 1.4521, AISI 444.

Fittings are made of chromium-nickel-molybdenum steel No. 1.4404, AISI 316L. Molybdenum content (min. 2,2%) determines the pipe's high resistance to corrosion. According to Directive EU 98, inclusion of nickel in the alloy does not result in exceeding the permissible values of nickel content in potable water $\leq (0,02 \text{ mg/l})$.

Fittings are offered with pressed ends and O-Ring seals, or with pressed and threaded ends with female or male threads, according to PN-EN 10226-1.

Physical properties of 1.4401, 1.4404, 1.4521 KAN-therm Inox pipes

Property	Symbol	Unit	Value	Remarks
Linear elongation coefficient	α	mm/m \times K	0,016	$\Delta t = 1 \text{ K}$
Thermal conductivity	λ	W/m \times K	15	
Minimal bending radius	R_{\min}		$3,5 \times D_e$	max. diameter 28 mm
Internal wall roughness	k	mm	0,0015	

3.2 Pipe diameters, lengths, weight and capacity

Scope of diameters $\varnothing 12$ to $\varnothing 168,3$ mm for wall thickness from 1,0 to 2 mm. Pipe length 6 m \pm 50 mm, end-capped.

Dimensions, weight by unit, water capacity of standard KAN-therm Inox pipes (1.4404)

DN	External diameter \times Wall thickness	Wall thickness	Internal diameter	Weight by unit	Length of the bar	Capacity by unit
	mm \times mm	mm	mm	kg/m	m	l/m
10	12 \times 1,0	1,0	10,0	0,270	6	0,080
12	15 \times 1,0	1,0	13,0	0,352	6	0,133
15	18 \times 1,0	1,0	16,0	0,427	6	0,201
20	22 \times 1,2	1,2	19,6	0,627	6	0,302
25	28 \times 1,2	1,2	25,6	0,808	6	0,515
32	35 \times 1,5	1,5	32,0	1,263	6	0,804
40	42 \times 1,5	1,5	39,0	1,527	6	1,195
50	54 \times 1,5	1,5	51,0	1,979	6	2,042
65	76,1 \times 2,0	2,0	72,1	3,725	6	4,080
80	88,9 \times 2,0	2,0	84,9	4,368	6	5,660
100	108 \times 2,0	2,0	104,0	5,328	6	8,490
125	139,7 \times 2,0	2,0	135,7	7,920	6	14,208
150	168,3 \times 2,0	2,0	164,3	9,541	6	20,893

Dimensions, weight by unit, water capacity of standard KAN-therm Inox pipes (1.4401 and 1.4521)

DN	External diameter × Wall thickness	Wall thickness	Internal diameter	Weight by unit	Length of the bar	Capacity by unit
	mm × mm	mm	mm	kg/m	m	l/m
12	15 × 1,0	1,0	13,0	0,352	6	0,133
15	18 × 1,0	1,0	16,0	0,427	6	0,201
20	22 × 1,2	1,2	19,6	0,627	6	0,302
25	28 × 1,2	1,2	25,6	0,808	6	0,514
32	35 × 1,5	1,5	32,0	1,263	6	0,804
40	42 × 1,5	1,5	39,0	1,527	6	1,194
50	54 × 1,5	1,5	51,0	1,979	6	2,042
65	76,1 × 2,0	2,0	72,1	3,725	6	4,080
80	88,9 × 2,0	2,0	84,9	4,368	6	5,660
100	108 × 2,0	2,0	104,0	5,328	6	8,490

The scope of application of the KAN-therm Inox system in construction is defined by the ITB National Technical Assessment

- permissible operating pressure up to 16 bar, medium: water, operating temperature 135 °C, diameter range 12–168 mm, using standard press tools with an "M" profile.
- maximum working pressure up to 25 bar, medium: water, working temperature 135 °C, diameter range 12–108 mm, using Novopress pressing tools fitted with jaws and slings with "M" profiles (diameters 12–28 mm) and "HP" (diameters 35–108 mm) and using 1.4401 stainless steel pipes.

! Notice: Working pressure of 25 bar does not include KAN-therm Steel and KAN-therm Inox ball valves and axial compensators.

Working pressure of 25 bar includes installations filled with water. If using other media, contact KAN Technical Support Department.

Test pressure can not exceed 25 bar during pressure tightness test.

With Viton O-Rings, continuous operation of the installation is possible in the temperature range -20 °C - 200 °C, also in the case of non-typical media.

3.3 Scope of use

- heating installations,
- hot and cold tap water installations (National Institute of Hygiene approval),
- treated water installations (desalinated, softened, decarbonated, deionized, demineralized and distilled),
- open and closed heating systems (water, glycol),
- open and closed chilled water installations (max. dissolved chloride contents 250 mg/l),
- solar installations (Viton O-Rings – working temperature up to 200 °C),
- fuel oil installations (Viton O-Rings),
- compressed air installations (details in "compressed air installations in KAN-therm system"),
- condensate installations applying the condensation technique for gas fuels (pH 3.5 to 5.2),
- technological installations in the industry.

The use of KAN-therm Inox pipes and fittings outside the scope of indoor water supply and heating installations, e.g. for media of non-typical chemical contents should be consulted with KAN's Technical Support Department (available questionnaire); Please provide i. a. the chemical content of the medium, maximum temperature and operating pressure, as well as ambient temperature in the questionnaire.



Exemplary KAN-therm Inox installation

4 Sealants – O-Rings

KAN-therm Steel and Inox pressed fittings are, by standard, equipped with O-Rings made of ethylene-propylene EPDM rubber observing the requirements of PN-EN 681-1. In the case of special applications, special Viton O-Rings may be supplied. Working parameters and scopes of use are presented in the table.

Material	Color	Working parameters	Use
EPDM ethylene-propylene rubber	black	<ul style="list-style-type: none"> ■ max working pressure: 16 or 25 bar (depending on the used tools, diameter range and transported medium) ■ working temperature: -35 °C to +135 °C ■ short-term: +150 °C 	installations: <ul style="list-style-type: none"> ■ potable water ■ hot water ■ central heating ■ conditioned water ■ glycol solutions* ■ fire fighting ■ compressed air (with no oil**)
FPM/Viton fluoride rubber	green	<ul style="list-style-type: none"> ■ max working pressure: 16 or 25 bar (depending on the used tools, diameter range and transported medium) ■ working temperature: -20 °C to +200 °C ■ short-term: +230 °C 	installations: <ul style="list-style-type: none"> ■ solar ■ compressed air ■ fuel oil ■ fuel ■ with vegetable fat ■ glycol solutions* <p>Notice: Do not use in potable water and pure hot water installations.</p>

* The use of antifreeze solutions based on propylene glycol and solutions based on ethylene glycol with a concentration of up to 50% is permitted; however, ethylene glycol solutions require the system manufacturer's approval.

** Maximum concentration of synthetic oils up to 5 mg/m³; mineral oils not allowed.

The possibility of using Viton O-Rings should be consulted with KAN's Technical Support Department. Replacement of O-Rings in between Inox and Steel fittings is not allowed.

Both EPDM and FPM O-rings are compatible with glycol solutions (ethylene and propylene). The use of a specific ethylene glycol solution requires the written approval of the installation system manufacturer.

In order to facilitate mounting KAN-therm Steel pipes inside the fittings, O-Rings are covered with Teflon (up to Ø54) and talcum powder (Ø76,1 – Ø108). O-Rings in Inox fittings are covered with talcum powder (all diameters). If, however, the use of another lubricant proves necessary, use water or soap. Do not cover O-Rings with grease, oil or fat. These substances might damage the joints. This also refers to contact with some types of paint used to cover pipes and fittings. Therefore, if the painting of installation is necessary, use O-Ring Viton to seal the connections. When standard EPDM O-Rings are used, only water-based paints are allowed.

The durability of KAN-therm Steel and Inox O-Rings has been tested and proven by the DVGW institute. According to test results, the life span of an O-Ring should be no shorter than 50 years.

KAN-therm Steel and Inox fittings up to 54 mm are equipped with special LBP O-Rings which guarantees fast detection of not-pressed joints in the installation during the preliminary stage of connecting to water supply (LBP function – Leak Before Press). Executed joints are signaled by water leaks. This useful function results from the unique structure of O-Rings having 3 special notches on the circumference. To ensure a fully functional and tight joint, after locating the leak, just press the joint.

For fittings with diameters greater than 54 mm, the LBP function is achieved by carefully selecting the tolerance between the O-ring diameter and the internal diameter of the fitting, which results in a controlled leak of the medium in the event of an unpressed connection.

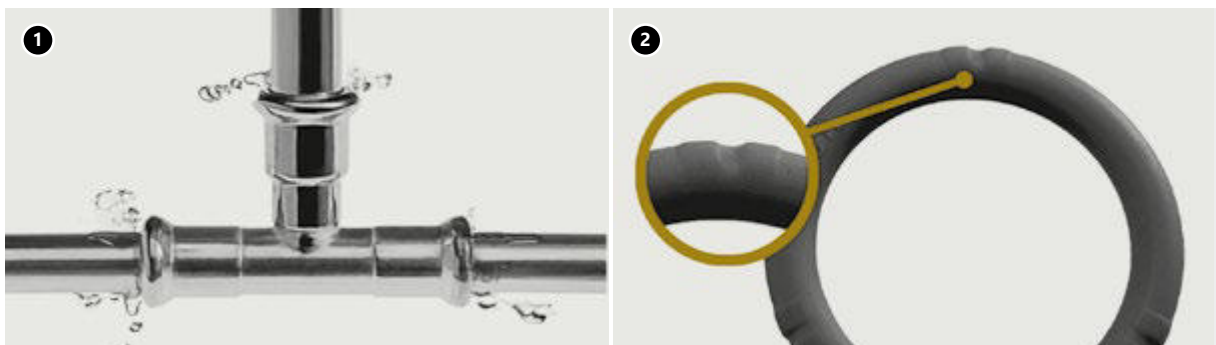

1. 1. O-Ring action with the LBP function of leakage detection
2. LBP O-Rings with a function of leakage detection

5 Durability, resistance to corrosion

Installation technology distinguishes various types of corrosion: chemical, electrochemical, internal or external, spot corrosion, corrosion produced by stray currents, etc. Such phenomena may be caused by specific physical and chemical factors related to the quality of installation materials, parameters of conducted media, external conditions, as well as the structure of the installation. Below, we present a few guidelines to be taken into account when designing, assembling and using KAN-therm Steel and Inox installations in order to avoid undesirable corrosive phenomena in metal installations.

The probability of occurrence of metal corrosion caused by stray currents (direct current passing through the pipeline material to the ground, disrupting the natural insulation layers, such as walls, pipe shields, etc.) is very small. This phenomenon is additionally reduced by introducing equipotential connections to the installation.

5.1 Internal corrosion

KAN-therm Steel installations

KAN-therm Steel pipes and fittings are made of high quality thin-walled carbon steel and are designed for use in closed installations. Oxygen dissolved in water facilitates corrosion, this is why its content in installation water should be maintained at a level below 0,1 mg/l.

In closed installations, access of oxygen from the environment is completely limited. A small amount of oxygen introduced in water when filling the installation will settle on the internal surface of pipes during their use, which will result in creating a thin layer of iron oxide, a natural anticorrosive layer. Therefore, draining water-filled installations should be avoided. If, after a pressure test, the installation is to be drained and remain unused for a longer period of time, we recommend using compressed air in pressure tests.

Any use of anti-freeze agents or corrosion inhibitors should be agreed on with KAN.

KAN-therm Inox installations

KAN-therm Inox pipes and fittings are perfect for transporting potable water (both cold and hot). They may also be used with treated water (softened, deionized, distilled), even water with conductivity below 0,1 $\mu\text{S}/\text{cm}$.

Stainless steel is resistant to nearly all components of the media transported in installations. Pay special attention to chlorides dissolved in water (halogens), since their action depends on their concentration and temperature (max 250 mg/l at 20 °C). No elements should be subjected to contact with highly concentrated ions of dissolved chlorides in temperatures above 50 °C. This is why you should:

- avoid sealants containing halogens which could dissolve in water (use plastic sealing tape, e.g. PARALIQ PM 35),
- avoid contact with oxygenated water with high chloride content (potable water with up to 0,6 mg/l chlorine content does not cause any adverse phenomena, the maximum permitted chlorine content in potable water is 0,3 mg/l). Water installations in the Inox system may be disinfected with a chlorine solution on the condition that its concentration in water does not exceed 1,34 mg/l, and that the installation is flushed twice after disinfection,
- local water heating by increased pipe wall temperature (e.g. heating cables in water supply installations) may lead to the precipitation of sediments on the internal surface of pipes, including chloride ions, which increase the risk of pit corrosion. In such case, the temperature of pipe wall should not exceed 60 °C permanently. Periodic (max 1 hour a day) water heating up to 70 °C for the purpose of thermal disinfection is permissible.

Direct connections of stainless steel elements with zinc-plated steel (fixtures, fittings) may result in contact corrosion of zinc-plated steel. Therefore, a bronze or brass element (e.g. coupling) of at least 50 mm must be used.

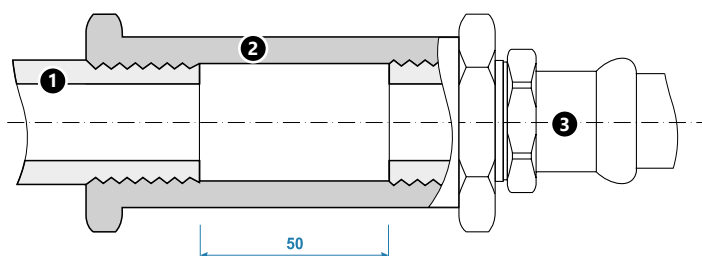

Principle of connecting KAN-therm Inox elements with zinc-plated steel
1. Steel pipe zinc-plated
2. Bronze or brass
3. Fitting with a KAN-therm Inox thread

It is also acceptable to make separable flange connections:

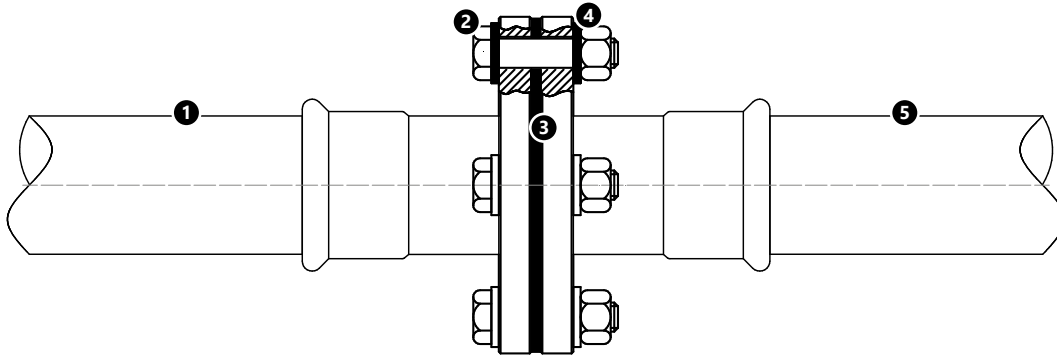

Case I:

1. KAN-therm Inox system,
2. stainless steel flange bolt and nut
3. elastomer or fibre sealing
4. metal washer with plastic casing
5. KAN-therm Steel system or traditional steel system.

Case II:

1. KAN-therm Inox system,
2. stainless steel flange bolt and nut
3. elastomer or fibre sealing
4. metal washer with plastic casing
5. KAN-therm Copper system or traditional copper system.

Case III:

1. KAN-therm Steel system
2. stainless steel flange bolt and nut
3. elastomer or fibre sealing
4. metal washer with plastic casing
5. KAN-therm Copper system or traditional copper or stainless system.

Remember that all of the above flange connections use bolts and nuts joining flanges made of stainless steel. Only in the case of connecting KAN-therm Steel system with zinc plated carbon steel it is possible to use bolts and nuts made of galvanised steel.

In water supply systems, remember of the liquid flow direction (the more corrosion-resistant metal should be placed behind the less corrosion-resistant metal, when looking in the direction of flow). That rule does not apply to closed liquid circuits.

In KAN-therm Inox and Steel systems, the is a possibility of using other materials (with intermediate elements, such as threaded or collar joints) depends on the type of installation.

5.2 External corrosion

Situations where Steel and Inox installations are exposed to external corrosion are relatively rare in indoor installations in the construction industry.

KAN-therm Inox installations

External corrosion of elements of the KAN-therm Inox system can occur when pipes or fittings are in a humid environment containing or producing compounds of chlorine or other halogens. Corrosion processes are intensified at temperatures above 50 °C.

In addition, elements of the KAN-therm Inox system can be installed and operated in environments with a corrosivity class no higher than C3 according to EN ISO 12944-2.

Therefore, in situations:

- contact with building components (e.g. mortar, insulation) emitting chlorine compounds,
- environment containing chlorine or its compounds in gaseous form or water containing salt (brine) or other halogen compounds,
- the use of the KAN-therm Inox system in an environment with a corrosivity class of C4 and higher, it is necessary to use full, watertight and non-absorbent waterproofing made of material with a closed cell structure that does not emit chlorides and halides.

If there is a risk of mechanical damage to the external insulations then these must be adequately protected, for example, with protective steel coating.

KAN-therm Steel installations

The pipes and fittings of the KAN therm Steel system are externally galvanised. This coating can be considered an effective corrosion protection in case of short-term contact with humid or chemically aggressive environments.

In a situation of long-term contact of the KAN-therm Steel system with a humid atmosphere (relative humidity permanently exceeding 65%), there is a risk of external corrosion of pipes and fittings. Pipes and fittings of the KAN-therm Steel system must be effectively protected against corrosion in the case of:

- installing the KAN therm Steel system in an environment with an elevated relative humidity permanently exceeding 65%,
- installing the KAN therm Steel system in an environment with a corrosivity class C2 and higher according to EN ISO 12944 2,
- using the KAN therm Steel system in an installation with a working medium temperature lower than the ambient temperature and/or in poorly ventilated rooms, where there is a high risk of condensation on the external surfaces of pipes and fittings (e.g. chilled water systems).

The protection of a system made of KAN-therm Steel pipes and fittings can be achieved by:

- insulate the installation with non-absorbent damp-proof insulation made of a material with a closed cell structure, arranged in such a way as to prevent water penetration and moisture in the pipes and fittings throughout the entire period of use. Particular attention should be paid to the tight protection of the contact points of insulation, valves, air vents and other fittings mounted on the pipe. The insulation must be tight throughout the entire service life of the pipelines.
- If there is a risk of mechanical damage to the external insulation, it must be adequately protected, e.g. with protective steel jackets.
- protection of the external surfaces of pipes and fittings by applying paint coatings suitable for galvanised surfaces. During the work, all guidelines of the manufacturer of the product used must be observed. The use of dedicated paint coatings is permitted:
 - water-dilutable acrylic paint when using EPDM seals,
 - solvent-based, phthalic paint when using Viton seals green



NOTE: A prerequisite for the proper operation of the installation (e.g. chilled water systems) is to protect it against the possibility of condensation (water vapor precipitating) on the external surfaces of KAN-therm Steel pipes and fittings throughout the entire period of use.

Any condensation of water vapor on the external surface of KAN-therm Steel pipes and fittings will result in a corrosion hotspot on these surfaces.

The occurrence of corrosion on the external surfaces of KAN-therm Steel products is not covered by the warranty.

If pipes and fittings have to be installed in corrosive environments and where it will be impossible or difficult to provide effective and durable corrosion protection, consideration should be given to the possibility of changing the material of the pipes and fittings and thus selecting an alternative solution based on plastic, stainless steel or copper pipes and fittings.

6 Technique of Press joints

KAN-therm Inox and Steel systems are based on the "Press" technique of executing joints, utilizing M-profiled jaws. This technique allows:

- applying three-surface pressure on the O-Ring, which ensures its correct deformation and adhesion to the pipe surface,
- fully enclosing the inner space, in which the O-Ring is settled – through screwing the edge of the fitting onto the surface of the pipe, which prevents pollutions from penetrating the interior of the fitting. Such structure serves as a natural mechanic shield to the seal and reinforcement to the joint,
- controlling the state of the joint through the structure of the O-Ring socket in the vicinity of the fitting edge.

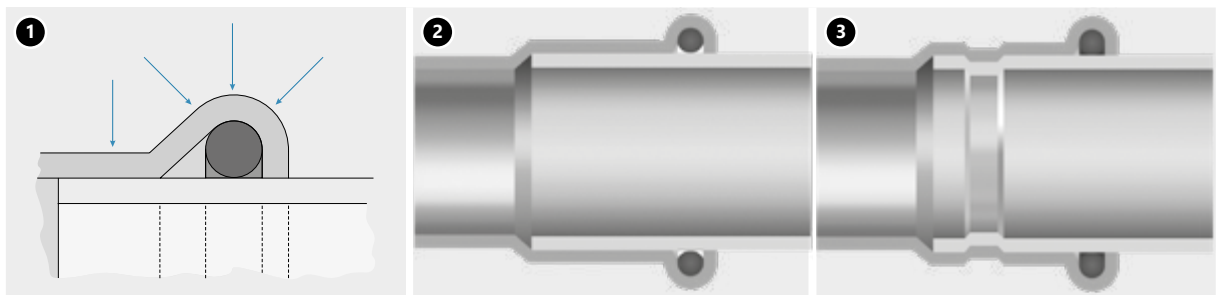

1. Pressure directions in a "Press" joint
 2. Cross-section of a joint before pressing
 3. Cross-section of the joint after pressing

6.1 Tools

In order to ensure a correct, water-tight connection, use proper tools. We suggest the use of cutters, deburrers and press machines as well as jaws offered by the KAN-therm system. There is a possibility of using other tools recommended by KAN (see table below).

To perform connections in KAN-therm Steel and KAN-therm Inox, use tools available in KAN-therm system offer - see the table below.

Producer	Press type		Diameter [mm]	Jaws/collars		Adapter		Type of KAN-therm system			
	Description	Code		Description	Code	Description	Code	Steel	Inox		
KAN-therm	AC 3000 DC 4000	1936267239 1936267238	12	M	1936267248	-	-	+	+		
			15	M	1936267249	-	-	+	+		
			18	M	1936267250	-	-	+	+		
			22	M	1936267251	-	-	+	+		
			28	M	1936267252	-	-	+	+		
			35	M	1936267253	-	-	+	+		
			42	M	1936267283			ZBS1	1936267285	+	+
			54	M	1936267284					+	+

Producer	Press type		Diameter [mm]	Jaws/collars		Adapter		Type of KAN-therm system	
	Description	Code		Description	Code	Description	Code	Steel	Inox
NOVOPRESS	ACO203XL EFP203 ¹⁾	1948267181 1948267210	12 ¹⁾	[J] M	1948267134	-	-	+	+
			15 ¹⁾	[J] M	1948267135	-	-	+	+
			18 ¹⁾	[J] M	1948267137	-	-	+	+
			22 ¹⁾	[J] M	1948267139	-	-	+	+
			28 ¹⁾	[J] M	1948267141	-	-	+	+
			35 ¹⁾	[J] M	1948267143	-	-	+	+
			35 ¹⁾	HP Snap On	1948267124			+	+
			42 ¹⁾	M Snap On	1948267119			+	+
			42 ¹⁾	HP Snap On	1948267126	ZB203	1948267000	+	+
			54 ¹⁾	M Snap On	1948267121			+	+
			54 ¹⁾	HP Snap On	1948267128			+	-
			66,7	M Snap On	1948267089			+	-
			76,1	M Snap On	1948267145	ZB221	1948267005	+	+
			88,9	M Snap On	1948267044			+	+
	108	M Snap On	1948267038	ZB221 ZB222	1948267005 1948267007	+	+		
	ACO102 ACO103	1948055007 1948055008	15	[J] M	1948267093	-	-	+	+
			18	[J] M	1948267095	-	-	+	+
			22	[J] M	1942121002	-	-	+	+
			28	[J] M	1948267097	-	-	+	+
			35	[J] M	1942121004	-	-	+	+
	ECO301 *	1948267163 *	12	[J] M	1948267084*	-	-	+	-
			15	[J] M	1948267085*	-	-	+	+
			18	[J] M	1948267087*	-	-	+	+
			22	[J] M	1948267164*	-	-	+	+
			28	[J] M	1948267165*	-	-	+	+
			35	HP Snap On	1948267124*			+	+
			42	HP Snap On	1948267126*	ZB 303*	1948267166*	+	+
	54	HP Snap On	1948267128*			+	+		
	66,7	M Snap On	1948267089*	ZB 323*	1948267009*	+	+		
	ACO401 ACO403	1948267151 1948267209	76,1	HP Snap On	1948267100	-	-	+	+
			88,9	HP Snap On	1948267102	-	-	+	+
			108	HP Snap On	1948267098	-	-	+	+
139,7			HP Snap On	1948267071	-	-	-	+	
168,3	HP	1948267072	-	-	-	+			
REMS	Power-Press SE Akku-Press Power-Press ACC	1936267160 1936267152 1936267219	12	[J] M	1948267046	-	-	+	+
			15	[J] M	1948267048	-	-	+	+
			18	[J] M	1948267052	-	-	+	+
			22	[J] M	1948267056	-	-	+	+
			28	[J] M	1948267061	-	-	+	+
			35	[J] M	1948267065	-	-	+	+
			42	[J] M	1948267067	-	-	+	+
54	[J] M	1948267069	-	-	+	+			
KLAUKE	KAN-therm Mini	1936055008	15	M	1936267278	-	-	+	+
			18	M	1936267279	-	-	+	+
			22	M	1936267280	-	-	+	+
			28	M	1936267282	-	-	+	+
	UAP100*	1948267159*	76,1	KSP3	1948267080	-	-	+	+
			88,9	KSP3	1948267082	-	-	+	+
108	KSP3	1948267074	-	-	+	+			

[J] - two segment jaw, other elements are collars / slings and may require cooperation with an adapter.

1) Limited diameter range - use selected press jaws

* The tools are not available in KAN-therm Steel and Inox offer.

To perform connections in KAN-therm Steel and KAN-therm Inox, other tools available on the market can also be utilized - see the table below.

Size	Manufacturer	Press type	Jaws/tongs
12–28 mm	Novopress	<ul style="list-style-type: none"> ■ Presskid (12 V) 	<ul style="list-style-type: none"> ■ Presskid: 12–28 mm jaws with inserts
12–35 mm	Novopress	<ul style="list-style-type: none"> ■ ACO102 (12 V) ■ ACO103 (12 V) ■ AFP 101 (9,6 V) 	<ul style="list-style-type: none"> ■ PB1 jaws: 12–35 mm
12–54 mm	Novopress	<ul style="list-style-type: none"> ■ ECO 1 Pressboy (230 V) ■ ECO 201/202 (230 V) ■ ACO 1 Pressboy (12 V) ■ ACO 3 Pressmax (12 V) ■ ACO 201 (14,4 V) ■ ACO 202 (18 V) ■ ACO 202XL (18 V) ■ EFP 2 (230 V) ■ EFP 201/202 (230 V) ■ EFP203 (230 V) ■ AFP 201/202 (14,4V) 	<ul style="list-style-type: none"> ■ PB2 jaws: 12–35 mm ■ Collars and adapters 35–54 mm: <ul style="list-style-type: none"> • Collars: HP35, 42 and 54 (with adapter ZB 201/ZB 203) • Snap On collars: HP35, 42 and 54 (with adapter ZB 201) • Snap On collars: HP35, HP42 and HP54 (with adapter ZB 203) ■ Collars for ACO 3 Pressmax are compatible with ZB 302/ZB 303 adapter • Collars: HP35, 42 and 54 (with adapter ZB 302/ZB 303) • Collars Snap On: HP35, 42 and 54 (with adapter ZB 303) <p>IMPORTANT: The HP54 jaws may only be used for crimping carbon steel (KAN-therm Steel system and KAN-therm Steel XPress Sprinkler) and stainless steel 1.4401 (KAN-therm Inox XPress Sprinkler system).</p>
12–108 mm	Novopress	<ul style="list-style-type: none"> ■ ECO 3 Pressmax (230 V) ■ ECO 301 (230 V) 	<ul style="list-style-type: none"> ■ PB3 jaws: 12–28 mm ■ Collars and adapters (ZB 302/ZB 303) 35–54 mm: <ul style="list-style-type: none"> • Collars: HP35, 42 and 54 (with adapter ZB 302/ZB 303) • Sling On collars: HP42 and HP54 (with adapter ZB 302) • Snap On collars: HP35, HP42 and HP54 (with adapter ZB 303) ■ Collars and adapters 76,1–108 mm: <ul style="list-style-type: none"> • Collars M66,7–88,9 mm (ZB 323 adapter) • Snap On collar M108 mm (two adapters required: ZB 323 and ZB 324) • Sling On collars M76,1–88,9 mm (ZB321 adapter) • Sling On collars M108 (two adapters required: ZB321 and ZB322) <p>IMPORTANT: Press in two stages (108 mm).</p>
76,1–168 mm	Novopress	<ul style="list-style-type: none"> ■ Hydraulic-Press-System ■ HCP /HA 5 ■ ACO 401 (18 V) ■ ACO403 (18 V) 	<ul style="list-style-type: none"> ■ Snap On collars HP76,1–139,7 mm ■ Sling On collars HP168,3 mm <p>IMPORTANT: Press in two stages (139,7 i 168,3 mm).</p>
12–28 mm	Klauke	<ul style="list-style-type: none"> ■ MAP1 "Klauke Mini" (9,6 V) ■ MAP2L "Klauke Mini" (18 V) 	<ul style="list-style-type: none"> ■ Mini Klauke jaws: 12–28 mm (28 mm jaw marked as "Only VSH")
12–54 mm	Klauke	<ul style="list-style-type: none"> ■ UAP2 (12 V) ■ UNP2 (230 V) ■ UP75 (12 V) ■ UAP3L (18 V) 	<ul style="list-style-type: none"> ■ Jaws: 12–54 mm (KSP3) ■ Collars and adapter: 42–54 mm (KSP3) <p>IMPORTANT: New M-Klauke Jaw kits (without pressing inserts) may be used as well as old M-Klauke Jaw kits (with pressing inserts).</p>
12–108 mm	Klauke	<ul style="list-style-type: none"> ■ UAP4 (12 V) ■ UAP4L (18 V) 	<ul style="list-style-type: none"> ■ Jaws: 12–54 mm (KSP3) ■ Collars and adapter: 42–54 mm (KSP3) ■ Collars and adapters: 76,1–168 mm (LP – KSP3)
76,1–108 mm	Klauke	<ul style="list-style-type: none"> ■ UAP100 (12 V) ■ UAP100L (18 V) 	<ul style="list-style-type: none"> ■ Collars: 76,1–108 mm (KSP3)
12-35 mm	Hilti	<ul style="list-style-type: none"> ■ NPR 019 IE-A22 	<ul style="list-style-type: none"> ■ NPR PM jaws: 12-35 mm
12-54 mm	Hilti	<ul style="list-style-type: none"> ■ NPR 032 IE-A22 	<ul style="list-style-type: none"> ■ NPR PS jaws: 12-35 mm ■ NPR PR collars: 42-54 mm
12-108 mm	Hilti	<ul style="list-style-type: none"> ■ NPR 032 PE-A22 	<ul style="list-style-type: none"> ■ NPR-PS collars: 12-35 mm ■ NPR PR jaws with adapter 42-88,9 mm (with NPR PA3 adapter), 108 mm (with NPR PA3+NPR PA4 adapter) <p>IMPORTANT: press in two stages (108 mm) Use Novopress SnapOn 67 clamps for a diameter of 66.7 mm. Hilti 66.7 mm clamps cannot be used.</p>
12-35 mm	Milwaukee	<ul style="list-style-type: none"> ■ M12 HPT-202C 	<ul style="list-style-type: none"> ■ J12 jaws: 12-35 mm
12-54 mm	Milwaukee	<ul style="list-style-type: none"> ■ M18 HPT-202C 	<ul style="list-style-type: none"> ■ J18 jaws: 12-35 mm ■ RJ collars: 42-54 mm (with RJ adapter)

Size	Manufacturer	Press type	Jaws/tongs
12–35 mm	REMS	<ul style="list-style-type: none"> ■ Mini Press ACC (12V) 	<ul style="list-style-type: none"> ■ REMS Mini Press jaws: 12–35 mm*
12–54 mm	REMS	<ul style="list-style-type: none"> ■ Powerpress 2000 (230 V) ■ Powerpress E (230 V) ■ Powerpress ACC (230 V) ■ Accu-Press (12 V) ■ Accu-Press ACC (12 V) 	<ul style="list-style-type: none"> ■ REMS jaws: 12–54 mm* (4G) ■ Collars and adapter: 42–54 mm (PR3-S)
12–108 mm	REMS	<ul style="list-style-type: none"> ■ Power-Press XL ACC 	<ul style="list-style-type: none"> ■ REMS jaws: 12–35 mm (2G) ■ REMS jaws: 42 mm (4G) ■ Collars and adapter: 42 mm (PR-3S + Z2) ■ REMS jaws: 54 mm (4G) ■ Collars and adapter: 54 mm (PR-3S + Z2) ■ Collars and adapter: XP66,7 mm (PR-3S + Z6 XL) ■ Collars and adapter: 76,1–108 mm (PR-3S + Z6 XL)
12–54 mm	Rothenberger	<ul style="list-style-type: none"> ■ Romax AC ECO ■ Romax 3000 Akku ■ Romax 3000 AC ■ Romax 4000 	<ul style="list-style-type: none"> ■ KAN-therm jaws M12–35 mm ■ KAN-therm collars M42–54 with adapter (ZBS1)

* only 18 and 28 mm forks marked as "108" (Q1 2008) or newer allowed

Utilization of other press tools requires consultation with the manufacturer of the installation system each time.



Tools – work safety

Before starting any works, make sure you read the instruction manual and learn the principles of safe work. All tools must be used according to their dedication and the manufacturer's instruction manual. During the use of tools, one must observe the terms of regular inspections and all applicable safety regulations. Using tools against their designed use may lead to their damage or to the damage of their accessories and pipes. It may also lead to the occurrence of leakages in installation joints.

KAN-therm tools:



1. Electric press KAN-therm AC 3000
2. Battery-powered press KAN-therm DC 4000
3. KAN-therm M22–54 mm jaws
4. Collar jaw M42-54 mm
5. Adapter ZBS1 42-54 mm

NOVOPRESS tools:



1. Battery-powered press ACO102
2. Battery-powered press ACO103
3. M15-35 mm jaw



1. Battery-powered press ACO203XL
2. PB2 M12-35 mm jaw
3. HP/M 35-108 Snap On press collar
4. ZB203 adapter
5. ZB221, ZB222 adapter



1. Electric press EFP203
2. PB2 M12-35 mm jaw
3. HP/M 35-54 Snap On press collar
4. ZB203 adapter



1. Electric press ECO 301*
 2. PB3 M12-28 mm jaw
 3. HP/M 35-66,7 Snap On press collar
 4. ZB303 adapter
 5. ZB323 adapter
- *Tool is not available in the KAN-therm system offer.



1. Battery-powered press ACO 401/ACO 403
2. HP 76,1-108 Snap On press collar
3. HP 139,7-168,3 mm press collar

REMS tools:

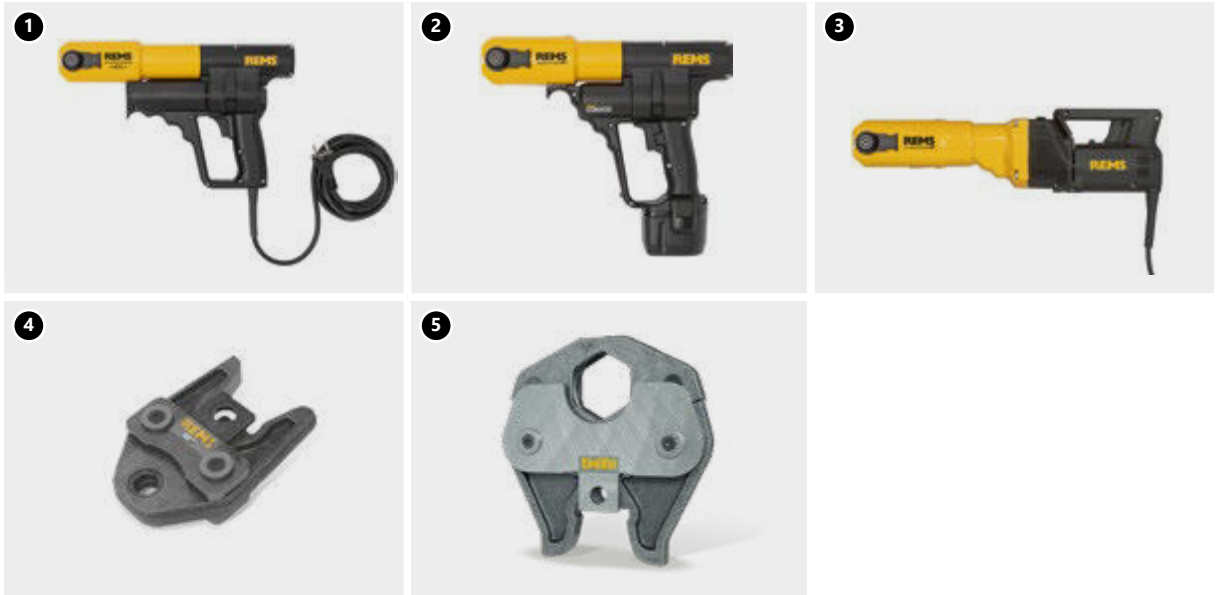

1. Electric press Power-Press ACC
2. Battery-powered press Akku-Press
3. Electric press Power-Press SE
4. M12–35 mm jaw
5. M42–54 mm jaw

KLAUKE tools:

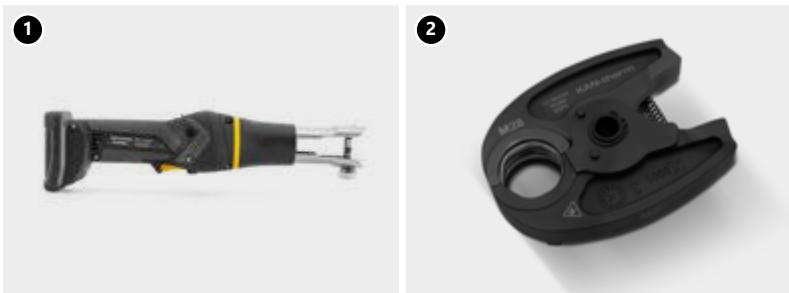

1. Battery-powered press KAN-therm Mini
2. SBM M 15–28 mm jaws



1. Battery-powered press UAP100*
2. 76,1 – 108 mm jaws*

*The tools are not available in the system KAN-therm offer.

6.2 Preparation of pipes for pressing



1. Cutting pipes

Cut pipes perpendicularly to the axis using a roll pipe cutter (breaking incompletely cut pipe sections is prohibited). You may also use other tools, such as hand saws and electric saws designed for cutting carbon or stainless steel, provided that the cut is made perpendicularly and the edges of the pipe are not chipped. Do not use torches or cutting discs for pipe cutting, which can generate significant amounts of heat, angle grinders, etc.



2. Chamfering

Use a manual chamfer (for diameters 76,1–168,3 – a semi-round steel file) to chamfer the internal and external edge of the pipe, removing all chips, which could potentially damage the O-Ring during assembly.



3. Inspection

Prior to assembly, visually inspect the presence and condition of the O-Ring. Check, if there are no chips or metal shavings or other pollutions on the pipe and the fitting, which could damage the seal during installation. Make sure if the distance between neighboring fittings is above the permissible (d_{min}).

4. Mounting the pipe and the joint

To achieve the correct strength of a joint, ensure a proper depth A (tab. 1, fig. 1) of inserting the pipe into the fitting. Before pressing, insert the pipe into the fitting up to the marked depth (slight rotation permissible). Do not use lubricants, greases or fats when mounting the pipe (water or a soap solution is permissible – recommended for pressure tests conducted with compressed air).



5. Marking the depth of the mount

In order to ensure the correct durability of your joint, maintain proper depth A (table on page 111) of mount of the pipe inside the fitting. When mounting multiple joints at the same time (sliding pipes into fittings), before pressing next joints, inspect the pipe insertion depth. To do this, just check if the pipe is inserted into the fitting as far as possible.

To facilitate the identification of the pipe insertion depth in the fitting, use a simple technique of marking with a marker. It consists in sliding the pipe into the fitting as far as possible and then making a mark on the pipe, right next to the very edge of the fitting socket. After pressing, this mark must still be visible right at the edge of the fitting.

You can also use special patterns to mark the sliding depth without checking it with the fitting.

Note: The patterns to mark the sliding depth are not part of the basic system offer and may be available depending on the markets where the product is sold.



6. Pressing joints

Before starting any works, read all suitable instruction manuals and verify the proper operation of your tools. Use press tools and jaws recommended by KAN.

Select the size of your press jaw basing on the diameter of the joint. Place the jaws on the joint so that its notch embraces the protruding part of the fitting (the space where the O-Ring is located). After starting the press, the process takes place automatically and cannot be stopped. If, for any reason, the process of pressing is stopped, the joint needs to be disassembled (cut off) and a new one needs to be executed. If the installer has press tools and jaws not supplied by the KAN-therm, the possibility of using them should be consulted with KAN's Technical Support Department.



7. Pressing 76,1–108 mm joints - preparing the jaws

To press the biggest diameters (76,1; 88,9; 108), use a special, four-part jaw (collar). After taking the jaws out of the box, unlock it. Next, open the jaws.

8. Mount the opened jaws on the fitting. The jaws are equipped with a special notch, which fits the collar on the fitting.

Notice: A label with the size of the jaws (visible on the figure) should be always located at the side of the pipe.

9. After the jaw is properly located on the fitting, it should be secured again by pressing the pin as far as possible (Klauke collars) or checking the alignment of the markers (Novopress collars). At this moment, the jaws are ready to be connected to the press machine.



10. Connecting the press machine to the jaws

Connect the press tool to the collar. It is absolutely necessary to ensure that the press tool is connected to the collar in accordance with the instructions attached to the specific tool.

A press machine connected this way may be started for the purpose of executing a fully pressed joint.

11. Pressing

The full time of executing one pressed joint is c.a. 1 min. (applies to diameters: 76,1–108 mm). After starting the press, the process takes place automatically and cannot be stopped. If, for any reason, the process of pressing is stopped, the joint needs to be disassembled (cut off) and a new one needs to be executed. After executing the pressed joint, the press machine will automatically return to its primary position. After that, remove the arms of the press machine from the jaws. To remove the collar from the fitting, unlock it again and then unfold it. Klauke collars should be stored in the suitcases in a secured condition - locked.



Note: The connection must not be crimped more than once, unless the installation instructions for the relevant diameter specify that double crimping is permitted.

Placing 139,7 - 168,3 collars on the fitting

For GigaSize diameters 139,7 – 168,3 in order to unfold the collar, press the pin shown in the photo (A), and then unfasten the connector (B).



Mount the opened collar on the fitting. The collars are equipped with a special notch, which fits the protrusion on the fitting. After mounting the collar on the fitting, lock them again by reinstalling the connector and locking the pin.

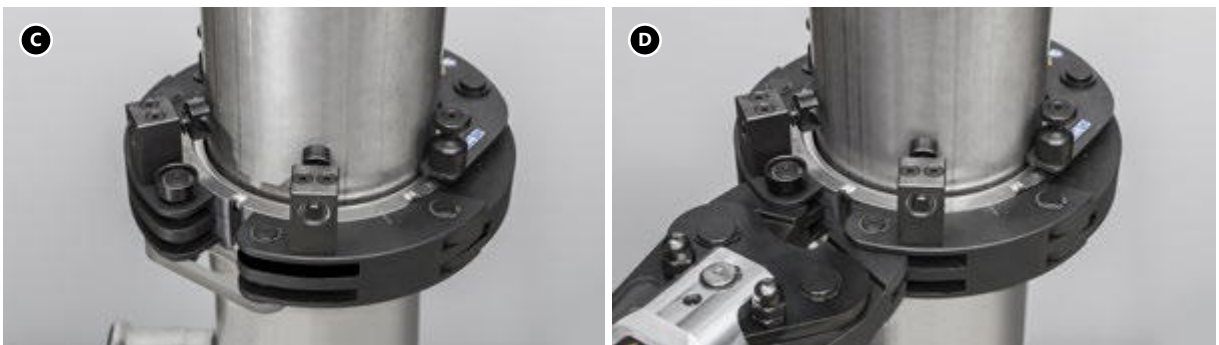

Connect the press tool to the collar. It is absolutely necessary to ensure that the press tool is connected to the collar in accordance with the instructions attached to the specific tool. The press tool connected to the collar can be started in order to fully press the first stage of the connection. After starting the press, the process takes place automatically and cannot be stopped. If, for any reason, the process of pressing is stopped, the joint needs to be disassembled (cut off) and a new one needs to be executed. After executing the pressed joint, the press machine will automatically return to its primary position. After that, remove the arms of the press machine from the collar.



Before performing the second stage of making the connection, the collar should be disassembled and then placed with rollers and spring pins in the place where the sealing O-Ring is installed. After the collar is properly mounted on the fitting, it should be secured again by pressing the pin and fastening the connector. Reconnect the press tool to the collar.

It is absolutely necessary to ensure that the press tool is connected to the collar in accordance with the instructions attached to the specific tool. The press tool connected to the collar can be started in order to fully press the second stage of the connection. The rules given at the first stage of the connection should be followed. After executing the pressed joint, the press machine will automatically return to its primary position. After that, remove the arms of the press machine from the collar.

Correctly made two-stage press connection with a diameter of 139,7 and 168,3 mm is characterized by a double ring imprinted on the fitting, as shown in the photo below:



Before each start of works and at intervals defined by the manufacturer, the tools should be checked and lubricated.

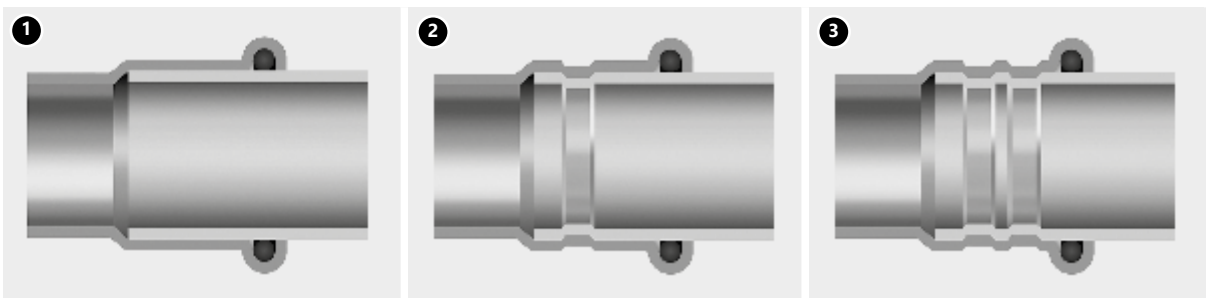

Press connection before (1) and after press (2, 3)

2. diameter range 12–108 mm

3. diameter range 139,7 and 168,3 mm

Pipe insertion depth in the fitting and minimum distance between pressed fittings

\varnothing [mm]	A [mm]	d_{min} [mm]	C_{min} [mm]
12	17	10	40
15	20	10	40
18	20	10	40
22	21	10	40
28	23	10	60
35	26	10	70
42	30	20	70
54	35	20	70
66,7	50	30	80
76,1	55	55	80
88,9	63	65	90
108	77	80	100
139,7	100	60	-
168,3	121	60	-

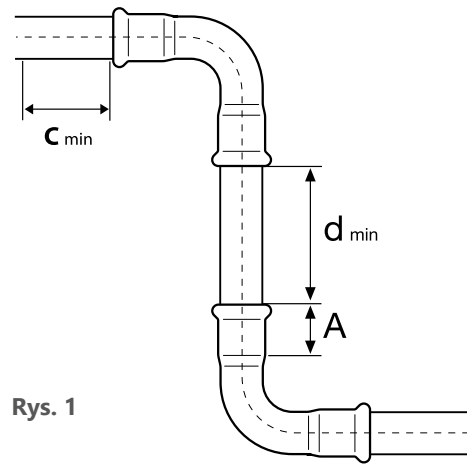

Rys. 1

- A – Pipe insertion depth in the fitting,
- d_{min} – minimum distance between fittings allowing press correctness
- C_{min} – minimal distance of fitting from wall

Minimal assembly distances

\varnothing [mm]	Fig. 1		Fig. 2		
	a [mm]	b [mm]	a [mm]	b [mm]	c [mm]
12/15	56	20	75	25	28
18	60	20	75	25	28
22	65	25	80	31	35
28	75	25	80	31	35
35	75	30	80	31	44
42	140/115*	60/75*	140/115*	60/75*	75
54	140/120*	60/85*	140/120*	60/85*	85
76	140*	110*	165*	115*	115
88	150*	120*	185*	125*	125
108	170*	140*	200*	135*	135
139	290*	230*	290*	230*	230*
168	330*	260*	330*	260*	260*

*applies to four-part pressing jaws

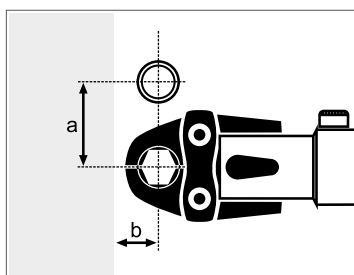

Fig. 1

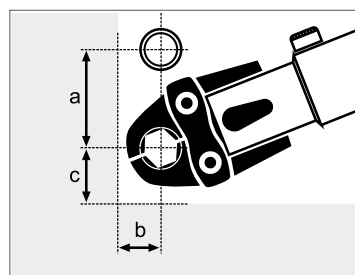

Fig. 2

6.3 Pipe bending

If there is a need, KAN-therm Steel and Inox pipes may be bent "cold", provided that the minimal bending radius R_{\min} is observed:

$$R_{\min} = 3,5 \times D_e$$

D_e – external diameter of the pipe

Do not bend the pipes "hot", due to the vulnerability of pipes processed this way to corrosion resulting from a change in the crystal structure of their material (KAN-therm Inox) and the possibility of damaging the zinc-plated layer of KAN-therm Steel pipes.

Use manual benders to bend the pipe. These may be electric or hydraulic. Do not "cold" bend pipes with diameters exceeding $\varnothing 28$ mm (use ready-made bends and elbows 90° and 45° supplied as part of the KAN-therm system).

Do not weld or solder KAN-therm Inox pipes, since this process changes the structure of material, which might lead to corrosion. Welding KAN-therm Steel pipes is not recommended (the anticorrosive zinc layer may be damaged).

6.4 Threaded fittings, connecting with other KAN-therm systems

Brass joint with male thread KAN-therm ultraLINE,
KAN-therm ultraPRESS

Steel joint with female thread KAN-therm
Steel, KAN-therm Inox

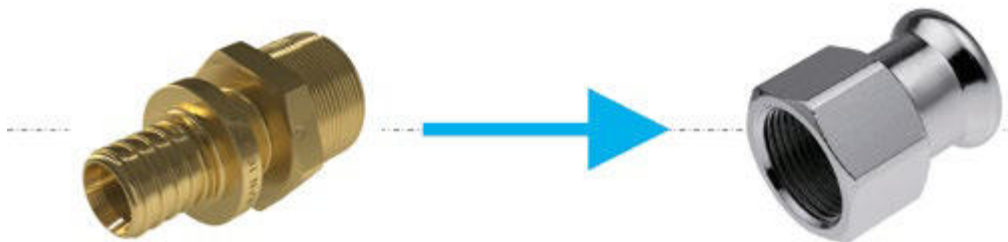

The principle of connecting KAN-therm Inox/Steel joints with brass fittings

KAN-therm Steel and Inox systems offer a wide selection of fittings with male and female threads. Since fittings with male threads are equipped with cone threads (pipe), in threaded joints with brass shape fittings, you can only use male threads for brass joints, sealed with e.g. a small amount of tow. It is suggested that the threaded (screwed) joint is executed before pressing the joint, so that no additional load is applied on the pressed joint. Do not use standard PTFE tape or any other solutions containing halides (e.g. chlorides) to seal threads in KAN-therm Inox installations.

Threaded fittings with other fixtures and threaded elements outside the system KAN-therm offer should be made in line with PN-EN 10226 (PN-ISO 7-1) and PN-EN ISO 228 depending on the thread type.

7 Flange connections



Table of Steel flange connections

Code	Size	Amount of screws/nuts	Screw size	Screw class	Nut class	Amount of washers	Flange	Flat seal
1509091000	35 DN32 PN16	4	M16	8.8	8	8	DN32	DN32 EPDM
1509091001	42 DN40 PN16	4	M16	8.8	8	8	DN40	DN40 EPDM
1509091002	54 DN50 PN16	4	M16	8.8	8	8	DN50	DN50 EPDM
1509091005	66,7 DN65 PN16	4	M16	8.8	8	8	DN65	DN65 EPDM
1509091003	76,1 DN65 PN16	4	M16	8.8	8	8	DN65	DN65 EPDM
1509091004	88,9 DN80 PN16	8	M16	8.8	8	16	DN80	DN80 EPDM
1509091010	108 DN100 PN16	8	M16	8.8	8	16	DN100	DN100 EPDM

Selection table for Inox flange connections

Code	Size	Amount of screws/nuts	Screw size	Screw class	Nut class	Amount of washers	Flange	Flat seal
1609091004	15 DN15 PN16	4	M12	8.8	8	8	DN15	DN12 EPDM
1609091005	18 DN15 PN16	4	M12	8.8	8	8	DN15	DN15 EPDM
1609091006	22 DN20 PN16	4	M12	8.8	8	8	DN20	DN20 EPDM
1609091007	28 DN25 PN16	4	M12	8.8	8	8	DN25	DN25 EPDM
1609091001	35 DN32 PN16	4	M16	8.8	8	8	DN32	DN32 EPDM
1609091008	42 DN40 PN16	4	M16	8.8	8	8	DN40	DN40 EPDM
1609091009	54 DN50 PN16	4	M16	8.8	8	8	DN50	DN50 EPDM
1609091002	76,1 DN65 PN16	4	M16	8.8	8	8	DN65	DN65 EPDM
1609091003	88,9 DN80 PN16	8	M16	8.8	8	16	DN80	DN80 EPDM
1609091000	108 DN100 PN16	8	M16	8.8	8	16	DN100	DN100 EPDM
1609091010	139,7 DN125 PN16	8	M18	8.8	8	16	DN125	DN125 EPDM
1609091011	168,3 DN150 PN16	8	M20	8.8	8	16	DN150	DN150 EPDM

8 Ball valves of KAN-therm Steel and KAN-therm Inox systems



Ball valves are intended for direct assembly on KAN-therm system pipelines using the radial pressing technique in profile "M". There are available versions with stub pipes pressed on both sides or pressed-on stub pipes and half union with flat sealing. The working pressure of 16 bar at working temperatures of -35 to +135 °C (150 °C short-term). The valves make it possible to shut off a part of an installation. When fully open, the valve has a minimum pressure drop. The valves have a 5-year manufacturer's guarantee.

Installation system	KAN-therm Steel system	KAN-therm Inox system
Construction materials	<ul style="list-style-type: none"> ■ body – carbon steel 1.0345 (RSt 37-8) electrogalvanised with 8÷15 µm thickness layer, ■ ball – brass CW617N or stainless steel 1.4401, ■ spindle and socket – stainless steel 1.4401, ■ lever – nylon reinforced with fibre PA66, ■ pipe stub sealing – EPDM70, ■ ball sealing – PTFE. 	<ul style="list-style-type: none"> ■ body – stainless steel 1.4404, ■ ball – stainless steel 1.4401, ■ spindle and socket – stainless steel 1.4401, ■ lever – nylon reinforced with fibre PA66, ■ pipe stub sealing – EPDM70, ■ ball sealing – PTFE.
Operating pressure	16 bar	
Operating temperature	-35 ÷ 135 °C	
Maximal temperature	150 °C	
Crimping profile	M	
Colour	silver, black lever	
Marking	System KAN-therm Manufactured in Denmark by BROEN	
Certification	ITB KOT	

KAN-therm Steel ball valves can be used in compressed air systems with the following requirements:

- the maximum humidity content does not exceed 0,5 g/m³ - class 7 acc. to ISO 8573-1
- and maximum oil content 5mg/m³ is not exceeded -class 4 acc. to ISO 8573-1.

KAN-therm Inox ball valves can be used in compressed air installations with the following requirements:

- the maximum oil content of 5 mg/m³ is not exceeded -class 4 acc. to ISO 8573-1.

Both KAN-therm Steel and KAN-therm Inox valves are not allowed to transport compressed air which contains mineral oils.

8.1 Service and maintenance

The valves do not need extra service under normal conditions, but to guarantee the good working of the valves, opening and closing the valve regularly is highly recommended, depending on medium and use. The table below can be used as a guideline in relation to operation and maintenance.

Medium	Function testing interval
Domestic hot water	Twice annually
Domestic hot water (calcareous)	4-6 times annually
Heating	Twice annually
Cooling	Twice annually
Compressed air	Once annually

9 Operational notes

9.1 Equipotential bonding

Every finished metal installation has to be provided with connections equalizing electrical potentials, i.e. grounded in order to prevent stray currents and occurrence of contact corrosion.

According to regulations in force, the connections of grounding conductors have to be made by welding or by threaded clamps and the connections to the pipelines must be made with screw clamps. In order to make the correct equipotential bonding, it is necessary to:

1. Get information on the applied electric shock protection solution (grounding method) in the building object.
2. Connect the equalizing conduit to the pipe with the appropriate clamp. In order to eliminate the risk of contact corrosion, the clamp must be selected according to the type of pipe.
3. Make the serial connections of all individual pipelines branches with a use of potentials equalization conduits and connect them to the main grounding collecting bar of the building object.



Attention!

Remove the insulation, paintwork and dirt from the pipe in clamp assembly places.

The length of the electrical conduits from the piping system to the grounding collecting bar of the potential equalization system should be as short as possible.

Calculations of the electrical potentials equalization system in the building object must be performed by person with appropriate qualifications.

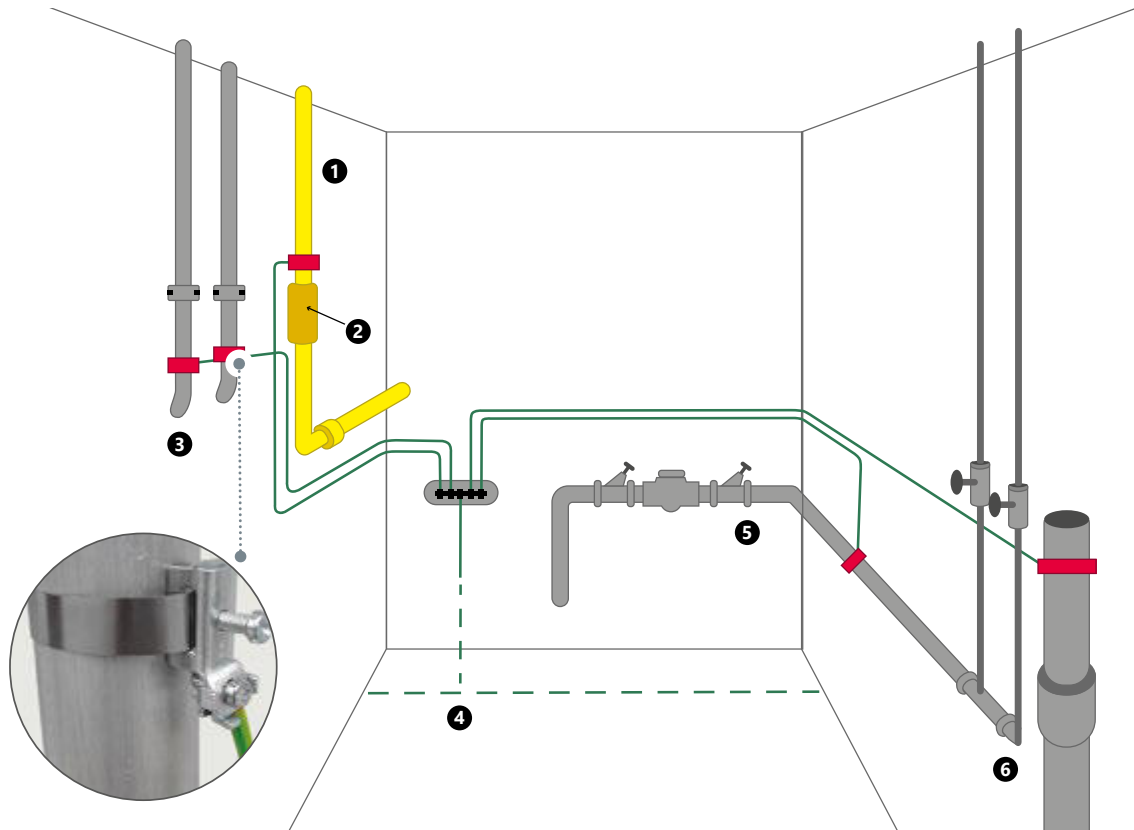

1. Gas
2. Insulation liner
3. Central heating
4. Foundation grounding
5. Water
6. Sewer

10 Transport and storage

- Elements of the KAN-therm Steel (carbon steel) and KAN-therm Inox (stainless steel) must be stored separately.
- Do not store elements of the system directly on the ground (e.g. on soil or concrete).
- Do not store elements of the system in the vicinity of chemical solutions.
- Pipe bundles should be stored and transported on wooden pallets (avoid direct contact with other steel elements, e.g. pipe stands).
- During transport, loading and unloading, be extra careful not to scratch or damage the pipes or fittings – do not: throw, drag or bend them.
- Rooms designed for storing elements of the system must be dry.
- During their storage, assembly and use, pipe surfaces must not be exposed to long-term, direct contact with water or humidity.



Detailed information about storage and transport of components can be found at en.kan-therm.com.



KAN-therm
MULTISYSTEM

> 35 | years of experience
on the installation
market



KAN-therm

Copper

**MODERN APPROACH
TO CLASSIC SOLUTIONS**

Install the **future**

EN 26/04

Ø **12-108 mm**

SYSTEM **KAN-therm** Copper

1	Modern connection technology	119
2	Durable connection technology	119
3	Applicability	120
4	Advantages	120
5	Assembly of connections	121
6	Tools	125
7	Tools – Safety	128
8	LBP function	128
9	Detailed information	128
10	Data on elongation and thermal conductivity	130
11	Recommendations for use	130
12	Threaded connections, connection to other KAN-therm systems	130
13	Flange connections	131
14	Transport and storage	132

SYSTEM **KAN-therm** Copper

KAN-therm Copper is a system of fittings made of high quality copper and bronze in diameters from Ø12 mm to Ø108 mm.

1 **Modern connection technology**

The press connection technology used in KAN-therm Copper system ensures reliable and fast connections by pressing the fittings on the pipe. The assembly is carried out using common press machines, eliminating the process of threading or soldering individual components.

KAN-therm Copper system fittings are made of high-quality Cu-DHP copper and 2.109 bronze.

Joining the elements in the "press" technology allows to obtain connections with a minimized narrowing of the pipe cross-section, which significantly reduces the pressure loss in the whole installation and creates excellent hydraulic conditions.

2 **Durable connection technology**

KAN-therm Copper system leak tightness is ensured by special O-Ring seals and an M-profile crimping at the three main points of the moulded part.

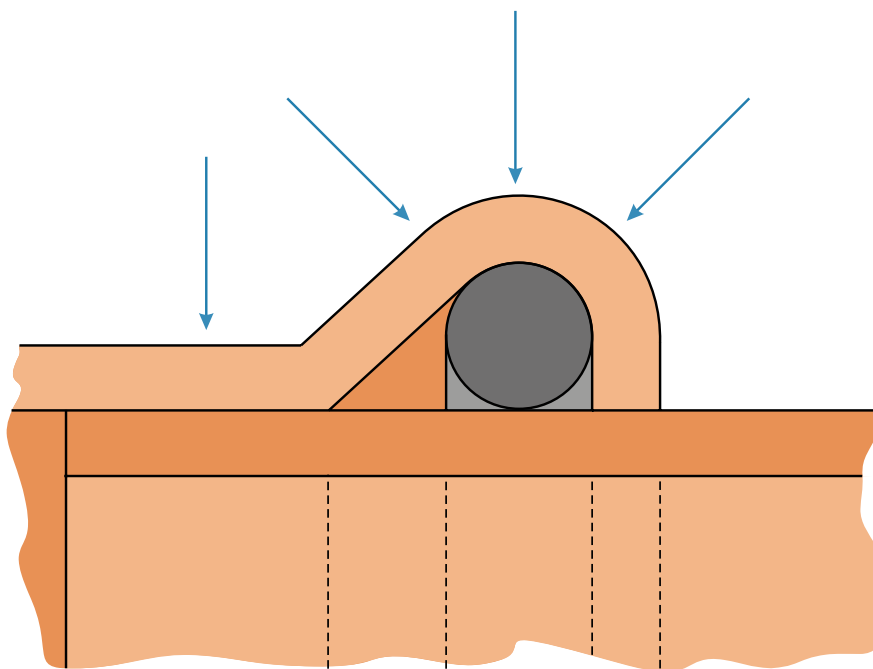

3 Applicability

- drinking water installations,
- heating installations,
- cooling installations (closed or open circuits),
- compressed air systems, (details in „compressed air installations in KAN-therm system”),
- solar installations and heating oil.

4 Advantages

- simple and fast connection technology – “press”,
- the most popular on the market, very accurate, three-point M crimping profile,
- quick and secure assembly, without soldering or threading,
- wide range of diameters 12–108 mm,
- LBP function – in the whole range of diameters,
- special design of the fitting for easy fixing on the pipe,
- high corrosion resistance,
- no fire hazard during installation and operation,
- high aesthetics of the installation.

5 Assembly of connections



1. Pipe cutting

Cut the pipe perpendicularly to its axis using a roll-cutter (the cut must be full without breaking off the cut pipe sections). It is permissible to use other tools provided that the cutting perpendicularity is maintained and that the cut edges are not damaged in the form of cracks, material losses and other deformations of the pipe cross-section. It is not permitted to use tools that can generate significant amounts of heat, e.g. torches, angle grinders, etc.



2. Chamfering of pipe edges

Using a handheld chamfer (for 66,7–108 mm diameters half-round file), chamfer the tip of the cut pipe inside and out and remove any swarf that may damage the O-Ring during installation.

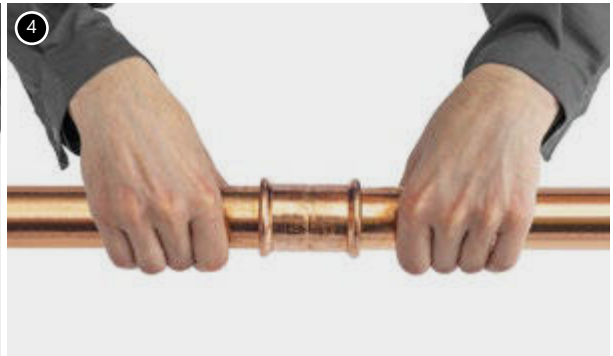

3. Control

Before installation, the presence of O-Rings in the fitting should be visually checked for damage, as well as for any contamination (swarf or other sharp objects) that may cause damage to the O-Rings during the pipe insertion phase. It is also necessary to make sure that the distance between adjacent fittings is not less than the permissible d_{min} (Table 1, Fig.1).

4. Installing the pipe and fitting

Before pressing, the pipe should be inserted axially into the coupling to the required depth (light rotary motion is permissible). The use of oils, greases and fats to facilitate the insertion of the pipe is prohibited (water or aqueous soap solution is permitted - recommended for pressure testing with compressed air).

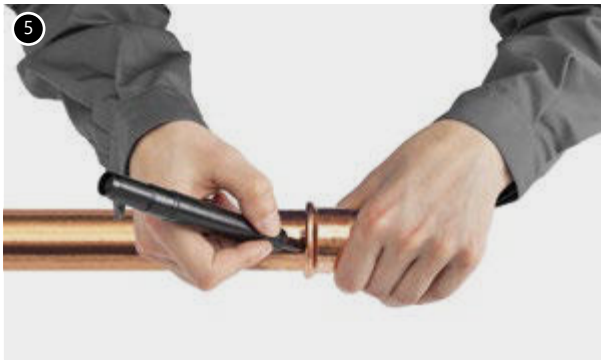

5. Mark the insertion depth of the pipe into the fitting

When mounting multiple joints at the same time (sliding pipes into fittings), before pressing next joints, inspect the depth of inserting the pipe into the fitting. To do this, just check if the pipe is inserted into the fitting as far as possible.

In order to achieve the proper strength of the connection, it is necessary to maintain the appropriate depth A (Table 1, Fig.1) of inserting the pipe into the fitting.

To facilitate the identification of the insertion depth of the pipe into the fitting use a simple technique of marking with marker.

It consists in sliding the pipe into the fitting as far as possible and then making a mark on the pipe, right next to the very edge of the fitting socket. After pressing, this mark must still be visible right at the edge of the fitting.

You can also use special patterns to mark the sliding depth without checking it with the fitting.

Note: The patterns to mark the sliding depth are not part of the basic KAN system offer.



6. Pressing fittings

Before starting the pressing process, check the efficiency of the tools.

The use of press jaws and machines supplied as parts of KAN-therm Copper system is recommended.

The size of the pressing jaw must always be selected according to the diameter of the connection to be made. The pressing jaw should be placed on the fitting in such a way that the groove inside the jaw exactly covers the place where the O-Ring is seated in the fitting (convex part of the fitting). Once the press machine been started, the pressing process is automatic and cannot be stopped. If, for some reason, the pressing process is interrupted, the connection must be disassembled (cut out) and a new one must be made in the correct way. If the installer has tools other than supplied by KAN-therm Copper system, the possibility of using them should be consulted with KAN's Technical Support Department.



7. Pressing of 42-108 mm fittings. Preparation of the jaws.

For pressing larger diameters (42, 54, 66,7, 76,1, 88,9, 108 mm), special Snap-on press collars are used.

The unfolded collar should be placed on the fitting. The jaws have a special groove in which the fitting should fit (the location of the O-Ring seal).

8. After correct seating collar on the fitting, connection is ready for pressing.



9. Connecting press tool to the collar

Press tool with a pre-mounted, suitable adapter must be connected to the collar.

It is essential to ensure that the pressing tool is connected to the collar in accordance with the instructions supplied with the tool. Press machine may be started to fully press the connection.

10. Pressing

After starting the press tool, the pressing process must not be stopped. If, for some reason, the pressing process is interrupted, the connection must be disassembled (cut out) and a new one must be made in the correct way. After pressing, the press machine automatically returns to its original position. The arms of the pressing tool (adapter) must then be pulled out of the collar. In order to remove the flange from the fitting (for diameters 42–108 mm), it must be unlocked again and then disassembled. Jaws and collars should be stored in suitcases in a secure, locked position.

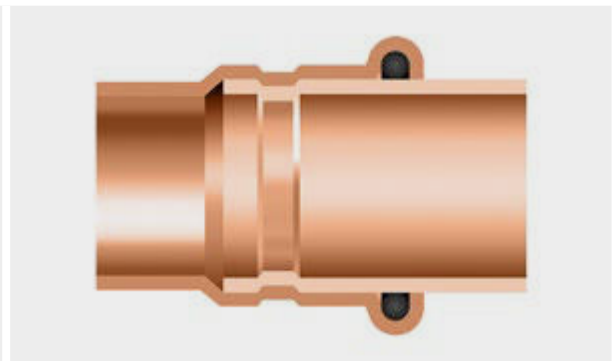
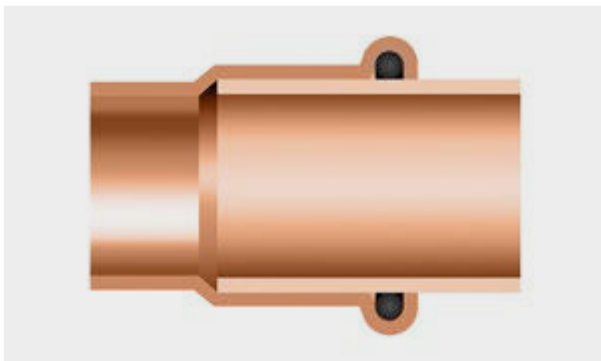

Fitting before and after pressing



Note: The connection must not be crimped more than once, unless the installation instructions for the relevant diameter specify that double crimping is permitted.

Mounting distances

Table 1. Insertion depth of the pipe into the fitting and minimum distance between the press fittings

\varnothing [mm]	A [mm]	d_{min} [mm]	c_{min} [mm]
12	17	10	40
15	20	10	40
18	20	10	40
22	21	10	40
28	23	10	60
35	26	10	70
42	30	20	70
54	35	20	70
66,7	50	30	80
76,1	50	55	80
88,9	64	65	90
108	64	80	100

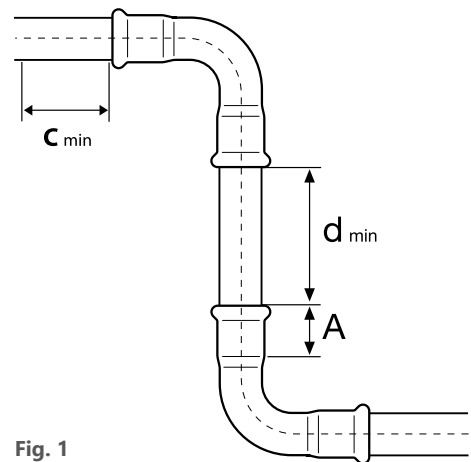

Fig. 1

A – insertion depth of the pipe into the fitting,
 d_{min} – minimum distance between fittings
 c_{min} – minimum distance of the fitting from the wall

Table 2. Minimum installation distances

Ø [mm]	Fig. 2		Fig. 3		
	a [mm]	b [mm]	a [mm]	b [mm]	c [mm]
12-15	56	20	75	25	28
18	60	20	75	25	28
22	65	25	80	31	35
28	75	25	80	31	35
35	75	30	80	31	44
42	115*	75*	115*	75*	75
54	120*	85*	120*	85*	85
66.7	145*	110*	145*	100*	100
76.1	140*	110*	165*	115*	115
88.9	150*	120*	185*	125*	125
108	170*	140*	200*	135*	135

*Applies to collars

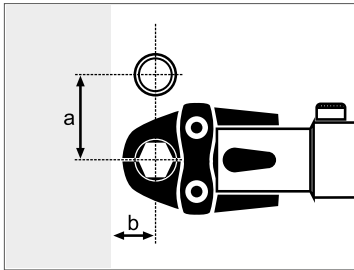

Fig. 2

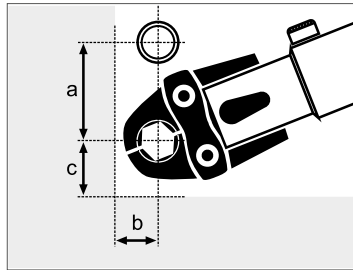

Fig. 3

6 Tools

Depending on the mounted diameter, KAN-therm system provides different tool configurations. In order to select an optimal set of tools, use the following selection table:

Table 3. Tool selection table: KAN-therm Copper system

Manufacturer	Type of crimping pliers		Diameter [mm]	Jaws/Pressing chains		Adapter	
	Description	Code		Description	Code	Description	Code
KAN-therm	AC 3000 DC 4000	1936267239 1936267238	15	M	1936267249	-	-
			18	M	1936267250	-	-
			22	M	1936267251	-	-
			28	M	1936267252	-	-
			35	M	1936267253	-	-
			42	M	1936267283	-	-
			54	M	1936267284	ZBS1	1936267285
NOVOPRESS	ACO203XL EFP203 ¹⁾	1948267181 1948267210	12 ¹⁾	[J] M	1948267134	-	-
			15 ¹⁾	[J] M	1948267135	-	-
			18 ¹⁾	[J] M	1948267137	-	-
			22 ¹⁾	[J] M	1948267139	-	-
			28 ¹⁾	[J] M	1948267141	-	-
			35 ¹⁾	[J] M	1948267143	-	-
			42 ¹⁾	M	1948267119	-	-
			54 ¹⁾	M	1948267121	ZB203	1948267000
			66,7	M	1948267089	-	-
			76,1	M	1948267145	ZB221	1948267005
			88,9	M	1948267044	-	-
			108 × 1,5 ^{**}	M	1905267017	ZB221 ZB222	1948267005 1948267007
			108 × 2,0 ^{**}	M	1948267038	-	-
REMS	ACO102 ACO103	1948055007 1948267208	12	[J] M	1936267268	-	-
			15	[J] M	1948267093	-	-
			18	[J] M	1948267095	-	-
			22	[J] M	1942121002	-	-
			28	[J] M	1948267097	-	-
			35	[J] M	1942121004	-	-
REMS	Power-Press SE AKU-Press Power-Press ACC	1936267160 1936267152 1936267219	12	[J] M	1948267046	-	-
			15	[J] M	1948267048	-	-
			18	[J] M	1948267052	-	-
			22	[J] M	1948267056	-	-
			28	[J] M	1948267061	-	-
			35	[J] M	1948267065	-	-
			42	[J] M	1948267067	-	-
			54	[J] M	1948267069	-	-
			42 *	[PR-3S] M	-	Z2 *	-
54 *	[PR-3S] M	-	-	-			
KLAUKE	KAN-therm Mini	1936055008	15	M	1936267278	-	-
			18	M	1936267279	-	-
			22	M	1936267280	-	-
			28	M	1936267282	-	-

[J] – two segment jaw, other elements are collars and require cooperation with an adapter

* Not available in KAN-therm Copper offer.

** Collar 108 × 1,5 use exclusively with 108 × 1,5 mm pipes

Collar 108 × 2,0 use exclusively with 108 × 2,0 mm pipes

¹⁾ Limited diameter range - use selected press jaws

KAN-therm tools:



1. Electric press KAN-therm AC 3000
2. Battery-powered press KAN-therm DC 4000
3. KAN-therm M22–54 mm jaws
4. Collar jaws M42-54 mm
5. Adapter ZBS1 42-54 mm)

NOVOPRESS tools:



1. Battery-powered press ACO102
2. Battery-powered press ACO103
3. PB1 M12–35 mm jaws

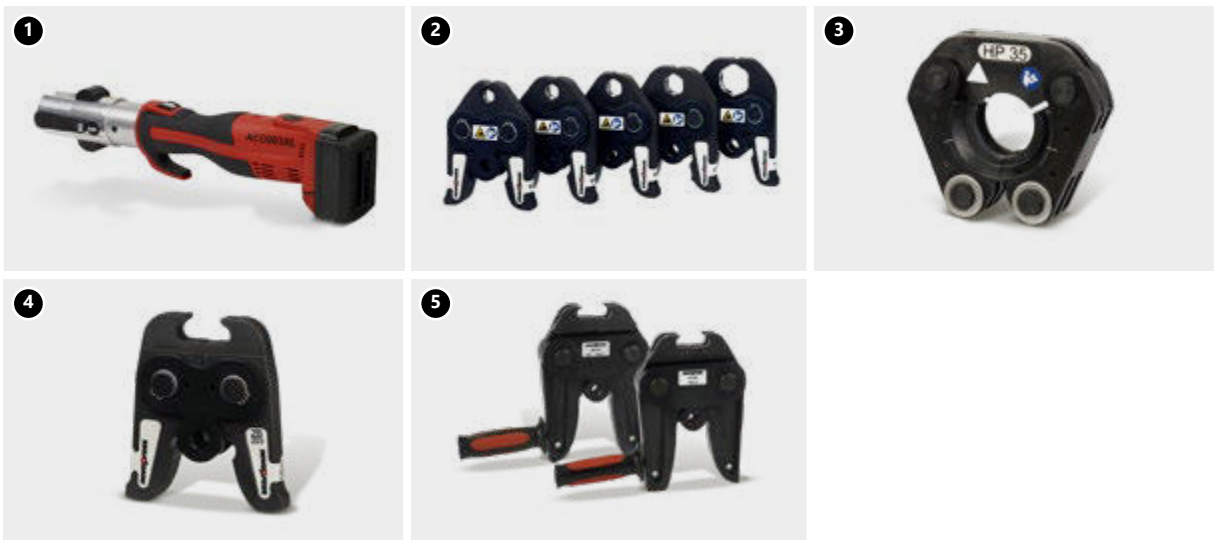

1. Battery-powered press ACO203XL
2. PB 2 M12–35 mm jaws
3. Snap On M 42–108 mm collars
4. Adapter ZB203
5. Adapter ZB221, ZB222



1. Electric press EFP203
2. PB2 M12–28 mm jaws
3. Snap On M 35–54 mm collars
4. Adapter ZB203

REMS tools:



1. Electric press Power-Press ACC
2. Battery-powered press Akku-ultraPRESS
3. Electric press Power-Press SE
4. M12–54 mm jaws

KLAUKE tools:



1. Battery-powered press KAN-therm Mini
2. SBM M15–28 mm jaws

7 Tools – Safety

All tools must be used and used in accordance with their intended use and the manufacturer's operating instructions. Use for any other purpose is deemed to be improper. Intended use also requires observance of the operating instructions, the inspection and maintenance conditions and the relevant safety regulations in their current version. Any work using this tool that does not correspond to the intended use can lead to tool, accessories and pipes damage. The consequence may be leaks and/or damage to the connection point between the pipe and the fitting.

8 LBP function

All KAN-therm Copper system fittings in the range of diameters 12–108 mm have the function of LBP (signalling of unpressed connections – "unpressed leaky" - LBP - Leak Before Press). The LBP function is realized by a proper construction of a fitting (body ovalization).



NOTE:

According to DVGW guidelines, the LBP function can be seen as controlled leakage at a pressure of:

- 1,0 to 3,0 bar in compressed air installations,
- 1,0 to 6,5 bar in installations filled with water.

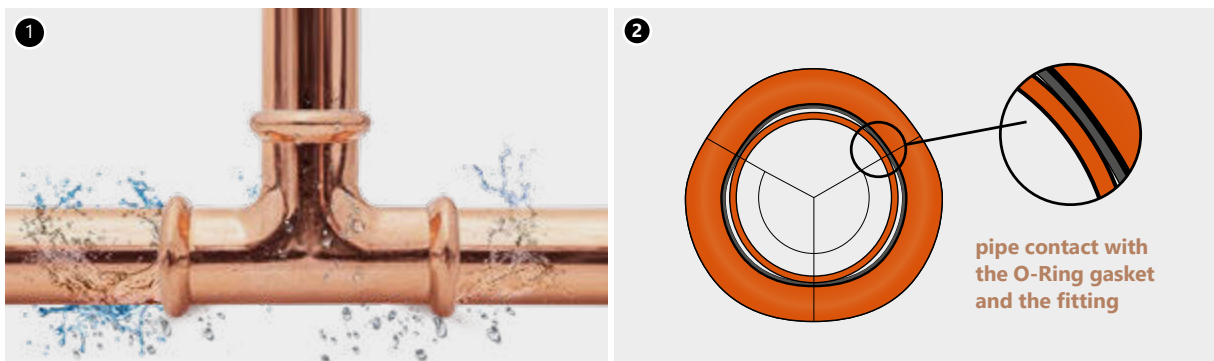

1. Signalling of unpressed connections LBP
2. The LBP function is performed by fitting body ovalization

9 Detailed information

Fittings - material

- copper Cu-DHP (CW024A) and bronze 2.109.

Pipes - Material and Compliance

KAN-therm Copper system consists of fittings only. Therefore, the pipes used in cooperation with the system must meet specific requirements and have the appropriate properties:



- copper pipes according to EN 1057 R220/R250/R290.

Tab. 4 Wall thickness depending on the external diameter of the copper pipe in accordance with EN 1057.

External diameter Ø [mm]	R220	R250	R290
12	-	0,7–1,0	0,7–1,0
15	1,0	1,0	1,0
18	1,0	1,0	1,0
22	1,0–1,1	0,9–1,2	0,9–1,2
28	-	0,9–1,2	0,9–1,5
35	-	-	0,9–1,5
42	-	1,2	1,2–1,5
54	-	1,2	1,2–2,0
64	-	-	2,0
66,7	-	1,2	1,2–2,0
76,1	-	-	2,0
88,9	-	-	2,0
108	-	1,5	1,5–2,5

A distinction is made between soft, medium-hard and hard tubes, R220, R250 and R290 respectively. The higher the value, the harder the pipe material is.

O-Rings

Name of the O-Ring	Properties and operating parameters	Application for seals
<p>EPDM (black)</p> 	<ul style="list-style-type: none"> ■ max. operating pressure 16 bar (10 bar for compressed air) ■ operating temperature -20 °C to +110 °C ■ short term +135 °C 	<ul style="list-style-type: none"> ■ drinking water ■ central heating ■ cooling water (closed and open systems) ■ compressed air (oil content up to 5 mg/m³) ■ marine installations
<p>FPM (green)</p> 	<ul style="list-style-type: none"> ■ max. working pressure 16 bar (10 bar for compressed air and solar installations) ■ operating temperature -20 °C to +200 °C ■ short term +230 °C 	<ul style="list-style-type: none"> ■ solar installations* ■ compressed air ■ inert gas installations ■ diesel oil transport installations ■ Note!!! Do not use in clean hot water installations.

* ATTENTION: Use only with R250/R290 pipes conforming to EN1057.



Copper fittings are fitted with O-Rings EPDM as standard, FPM seals must be completed separately.

For special applications such as oil containing or high temperature media, FPM O-Rings are supplied separately. If it is necessary to replace standard EPDM O-Rings with FPMs, reuse of dismantled O-Rings is prohibited. Applications outside the scope of indoor hot and cold water or heating systems should be consulted with KAN's Technical Support Department on a case-by-case basis.

10 Data on elongation and thermal conductivity

Type of material	Thermal expansion coefficient	4 m segment expansion at 60 °C temperature difference	Thermal conductivity
	[mm/(m × K)]	[mm]	[W/m × K]
Copper	0,0170	1,02	397

11 Recommendations for use

- KAN-therm Copper system fittings made of copper Cu-DHP and bronze 2.109 cannot be used in installations that will be exposed to additional mechanical loads (e.g. hanging on pipelines, devastation, etc.),
- Copper pipes according to EN 1057 and DVGW-GW 392 must not be bent "hot" due to the risk of corrosion. "Cold" bending is permitted provided that the minimum bending radius $R=3,5 \times D_{ext}$ is maintained,
- It is not recommended to bend pipes over 54 mm in diameter,
- It is recommended to use ready-made bends and elbows 90° and 45° angle as part of KAN-therm Copper system,
- To cut pipes, do not use tools that can generate significant amounts of heat, e.g. torches, angle grinders, etc. Roll-cutters (manual and mechanical) are used to cut copper pipes,
- In case of running pipelines inside of building partitions, pipelines should be insulated, due to compensation of thermal elongations and protection against building chemistry. To avoid external corrosion, make sure that the insulation materials do not contain any traces of ammonia or nitrate,
- When using external heat sources (e.g. heating cables) to heat the pipe wall, the pipe wall temperature must not exceed 60 °C,
- If you are transporting a medium other than those included in this technical catalogue, the possibility of using KAN-therm Copper system should be consulted with the KAN's Technical Support Department,
- Installations made in KAN-therm Copper system must be electrically connected and grounded,
- Pipes intended for water installations that are to be built into partitions (e.g. walls or floors) must always have a shell/sleeve made of suitable material to ensure that the pipe does not come into contact with the building structure (due to noise problems).

12 Threaded connections, connection to other KAN-therm systems

KAN-therm Copper system offers a full range of connectors with male and female threads. Since there are conical threads in the fittings, it is suggested to use only male threads sealed with tow in the threaded connections for brass fittings.

In order not to strain pressed connection, it is recommended to make a threaded connection before pressing the connector.

Thread sealing

For threaded connections, use such amount of tow so that the thread peaks are still visible. If you use too much tow, the thread can be destroyed. Wrapping the tow just after the first thread reel avoids oblique screwing and damage to the thread.



Note

Do not use chemical sealants or adhesives.

KAN-therm Copper system components can be combined (through thread or flange connections) with components made of other materials (see table below).

Possibilities of combining KAN-therm Copper system with other materials

Type of installation	Pipes/fittings			
	Copper	Bronze/Brass	Carbon steel	Stainless steel
Copper	enclosed	yes	yes	yes
	open	yes	yes	no

Please note that direct joining of copper parts with stainless steel and galvanized carbon steel parts can lead to contact corrosion.

You can eliminate this process by using separable threaded connections (threaded fittings of KAN-therm Copper system are made of bronze – their direct contact with stainless or carbon steel is acceptable) and separable flange connections using elastomer sealing.

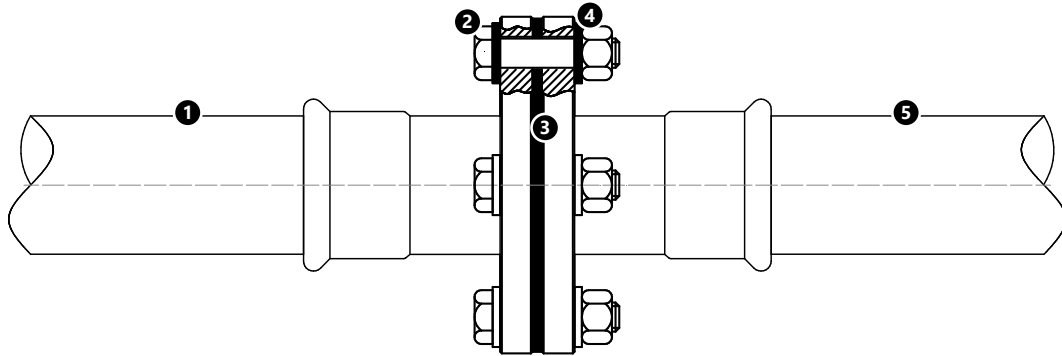

1. KAN-therm Copper system.
2. Stainless steel flange bolt and nut.
3. Elastomer or fibre sealing.
4. Metal washer with plastic casing.
5. KAN-therm Steel, KAN-therm Inox systems or any traditional steel system.

13 Flange connections



Selection table for Copper flange connections

Code	Size	Number of bolts/nuts	Screw size	Screw class	Nut class	Number of washers	Collar	Flat seal
2265091000	66,7 DN65 PN16	4	M16	8,8	8	8	DN65	DN65 EPDM
2265091004	76,1 DN65 PN16	4	M16	8,8	8	8	DN65	DN65 EPDM
2265091001	76,1 DN80 PN16	8	M16	8,8	8	16	DN65	DN65 EPDM
2265091002	88,9 DN80 PN16	8	M16	8,8	8	16	DN80	DN80 EPDM
2265091003	108 DN100 PN16	8	M16	8,8	8	16	DN100	DN100 EPDM

14 Transport and storage

- Elements of the KAN-therm Copper must be stored separately from other metal systems.
- Do not store elements of the system directly on the ground (e.g. on soil or concrete).
- Do not store elements of the system in the vicinity of chemical solutions.
- During transport, loading and unloading, be extra careful not to scratch or damage the pipes or fittings – do not throw, drag or bend them.
- Rooms designed for storing elements of the system must be dry.
- During their storage, assembly and use, products surfaces must not be exposed to long-term, direct contact with water or humidity.



Detailed information about storage and transport of components can be found at en.kan-therm.com.



KAN-therm
MULTISYSTEM

> 35 | years of experience
on the installation
market



KAN-therm

Cabinets and manifolds

QUALITY AND RELIABILITY

Install the **future**

Manifolds and cabinets for radiator heating and potable water systems

1	KAN-therm InoxFlow manifolds	135
2	Installation cabinets	136

Manifolds and cabinets for radiator heating and potable water systems

1 KAN-therm InoxFlow manifolds

KAN-therm system offer includes InoxFlow manifolds made of stainless steel 1.4301 (AISI 304) with a 1 ¼" profile. These manifolds consist of beams (supply and return) with installation connections GW 1" and two clamps equipped with elastomer inserts damping vibrations. The complementary fittings used are made of non-nickel CW617N brass.

These manifolds can operate at 10 bar pressure and a temperature of 80 °C ($T_{max} = 90\text{ °C}$).

It is allowed to use both water and written-approved antifreeze mixtures based on glycol solutions with a concentration of $\leq 50\%$.

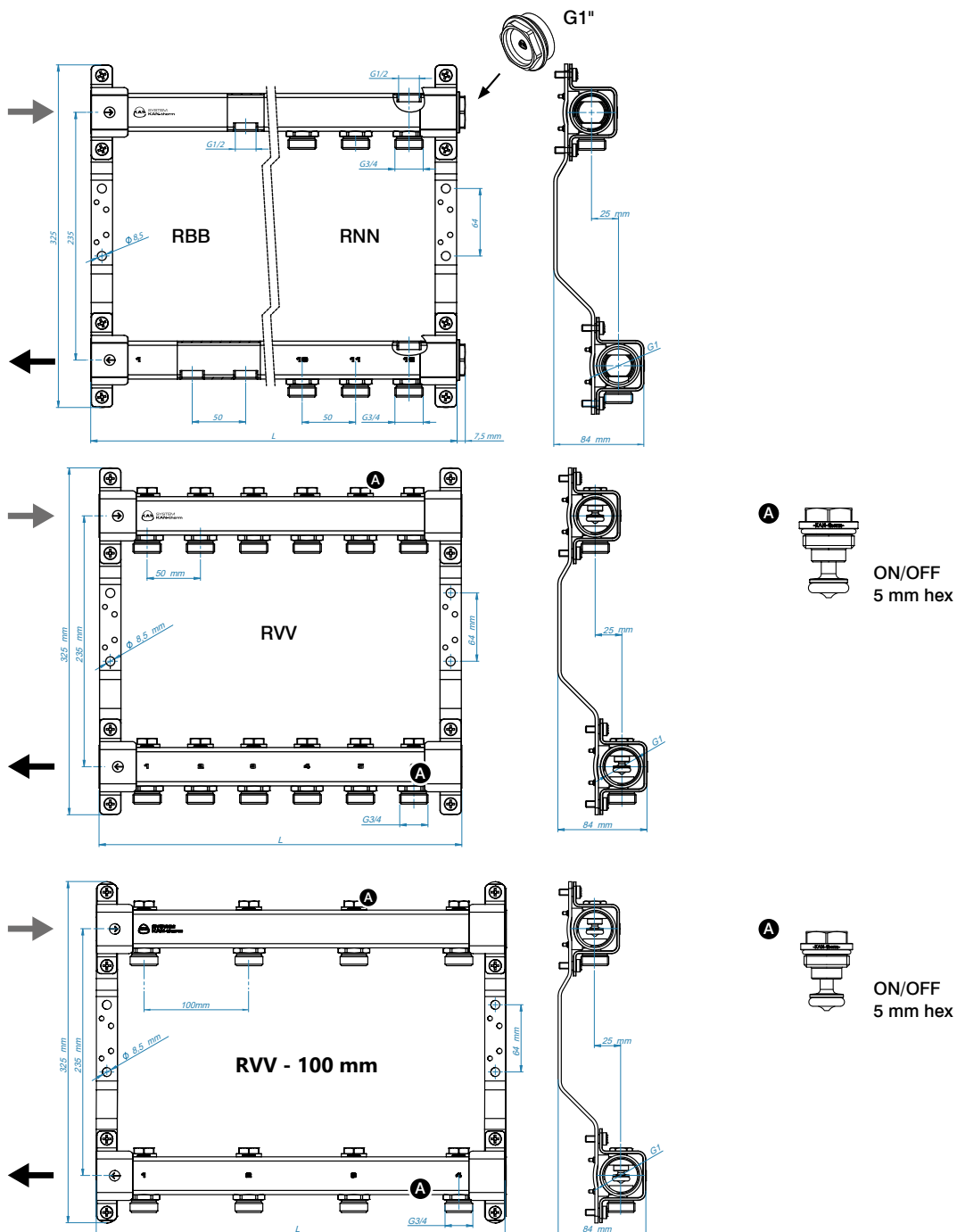

Depending on the equipment used, these manifolds are divided into series:

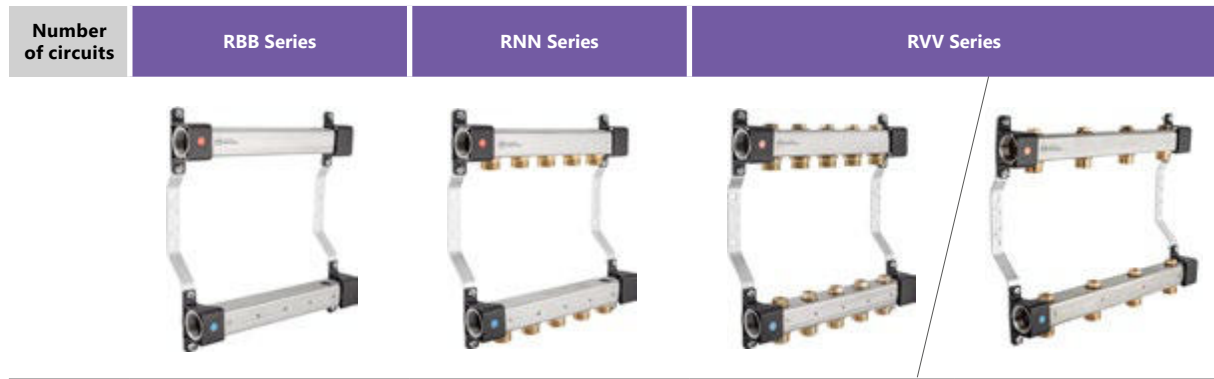

Number of circuits	L [mm]		
	RBB Series	RNN Series	RVV Series
2	140 +7,5	140 +7,5	140 (190*)
3	190 +7,5	190 +7,5	190 (290*)
4	240 +7,5	240 +7,5	240 (390*)
5	290 +7,5	290 +7,5	290 (490*)
6	340 +7,5	340 +7,5	340 (590*)
7	390 +7,5	390 +7,5	390
8	440 +7,5	440 +7,5	440
9	490 +7,5	490 +7,5	490
10	540 +7,5	540 +7,5	540
11	590 +7,5	590 +7,5	590
12	640 +7,5	640 +7,5	640

*sizes in brackets refer to manifolds with 100 mm outputs spacing

Equipment	RBB Series	RNN Series	RVV Series
	<ul style="list-style-type: none"> - female 1/2" threads as outputs for individual circuits, - 1/2 "hole in the upper part of the beams for the vent, - 1 "plugs at the right side of the beams. 	<ul style="list-style-type: none"> - G3/4 " nipples with 50 mm spacing as outputs for individual circuits, - 1/2 "hole in the upper part of the beams for the vent, - 1 "plugs at the right side of the beams. 	<ul style="list-style-type: none"> - G3/4 "nipples with 50 or 100 mm spacing as outputs for individual circuits with additionally equipped with shut-off valves, - open beams on both sides.

2 Installation cabinets

The manifolds are most often placed in installation cabinets in order to hide and protect them from non-authorized persons. KAN-therm offer includes both surface-mounted cabinets (mounted on the face of the walls) and recess-mounted cabinets (mounted in a previously prepared wall groove). All cabinets are made of galvanized sheet metal on both sides and covered with a durable varnish layer in RAL 9016 (white). Recess-mounted cabinets are additionally secured with a layer of protective foil. All cabinets are equipped with coin / screwdriver locks.

Recess-mounted cabinets

Slim

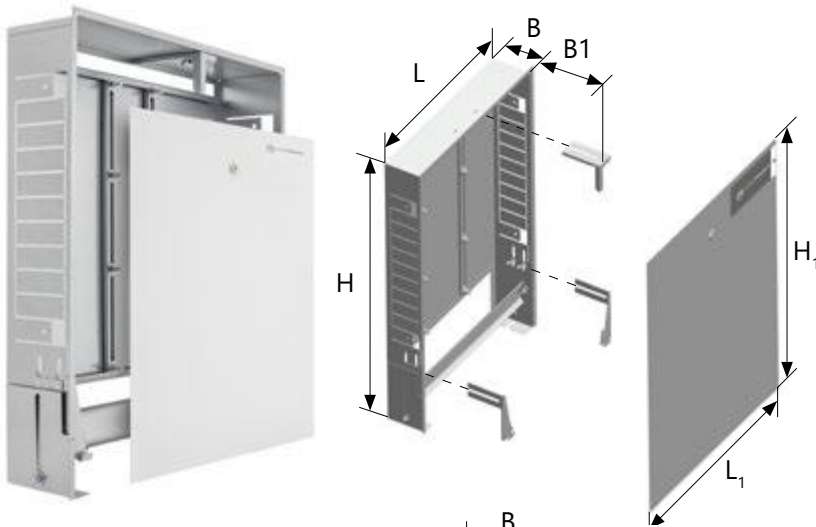

SWPS

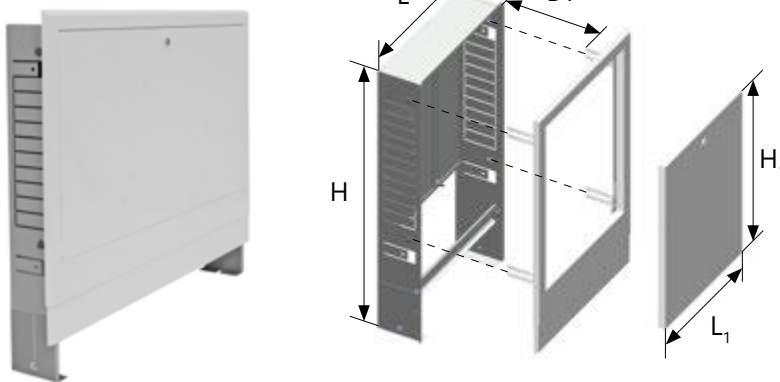

SWPSE

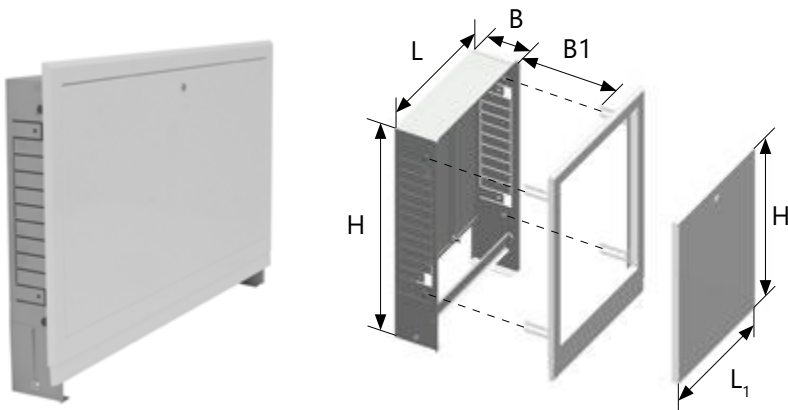

Typ	Dimension [mm]						Number of circuits of InoxFlow manifold	
	L	H	B	L1	H1	B1	-	set
Slim	Slim 350	350		418			5	2
	Slim 450	450		518			7	4
	Slim 580	580	560-660	648	595-725	112-162	9	6
	Slim 780	780		848			12	10
	Slim 930	930		998			12	12
SWPS*	SWPS-4	350		340			5	2
	SWPS-6	450		440			7	4
	SWPS-10/3	580	680-780	570	434	0-50	9	6
	SWPS-13/7	780		770			12	10
	SWPS-15/10	930		920			12	12
SWPSE	SWPSE-4	350		340			5	2
	SWPSE-6	450		440			7	4
	SWPSE-10/3	580	680-780	570	434	0-50	9	6
	SWPSE-13/7	780		770			12	10
	SWPSE-15/10	930		920			12	12

*product withdrawn from the offer

Surface mounted cabinets

SWN

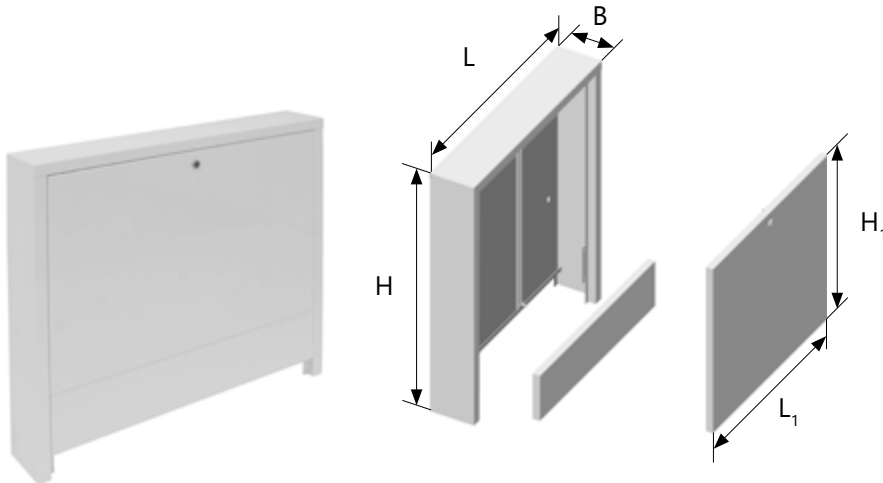

SWNE

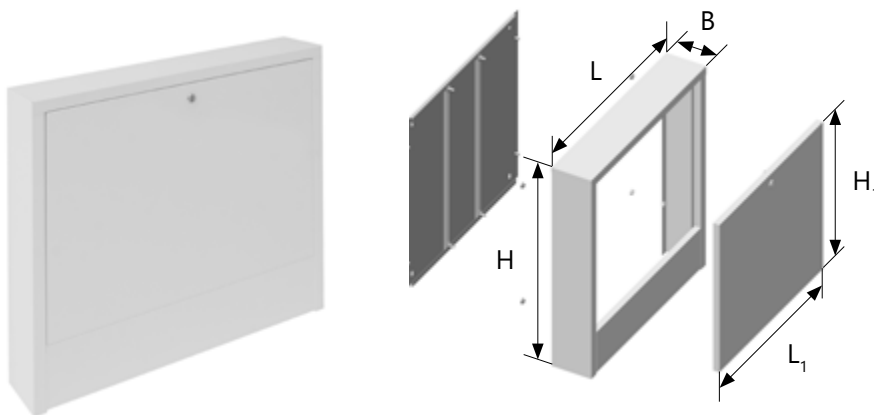

Typ	Dimension [mm]					Number of circuits of InoxFlow manifold		
	L	H	B	L1	H1	-	set	
SWN*	SWN-4	350	630	110	297	434	4	x
	SWN-6	450			397		6	2
	SWN-8	550			497		8	4
	SWN-10	650			597		10	6
	SWN-13	800			747		12	9
SWNE	SWNE-4	350	585	110	297	434	4	x
	SWNE-6	450			397		6	2
	SWNE-8	550			497		8	4
	SWNE-10	650			597		10	6
	SWNE-13	800			747		12	9

*product withdrawn from the offer



**KAN-therm
MULTISYSTEM**

> 35 | years of experience
on the installation
market



KAN-therm
**Guidelines for
installation design
and assembly**

Install the **future**

Guidelines for installation design and assembly

1	Assembly of KAN-therm system at temperatures below 0 °C	141
2	Mounting KAN-therm system pipelines	143
2.1	Clamps and hangers	143
2.2	PP shifting points	144
2.3	PS fixed points	144
2.4	Passages through building partitions	147
2.5	Support spans	149
3	Compensation of thermal elongation of pipelines	151
3.1	Linear thermal elongation	151
3.2	Compensation of elongations	155
3.3	Compensators in KAN-therm system installations	158
4	Principles of laying KAN-therm installations	165
4.1	On-plaster installations – risers and horizontal pipelines	165
4.2	Conducting KAN-therm installations in structural partitions	166
4.3	Layout of KAN-therm installation	168
5	Connecting installation made of plastic pipes to the heat sources	171
5.1	Radiator connections	171
5.2	Union connectors for metal pipes	172
5.3	Water supply device connections	173
5.4	Requirements for fixing fittings in connection zones	173
5.5	Radiator connections	174
5.6	Tap connections	179
6	Compressed air installations in KAN-therm system	181
7	Rinsing, tightness tests and disinfection of KAN-therm installations	183
7.1	Water pressure test	183
7.2	Tightness tests with compressed air	184
8	KAN-therm system installation disinfection	186

Guidelines for installation design and assembly

1 Assembly of KAN-therm system at temperatures below 0 °C

The standard assembly of plastic KAN-therm system should be conducted at ambient temperatures above 0 °C. Guidelines given in the previous chapters of this guide should be observed.

Due to the changing weather conditions and ambient temperature which may occur on-site installation, in specific cases, it is permissible to perform assembly of plastic KAN-therm systems at an ambient temperature reaching up to -10 °C (assembly of KAN-therm Steel, KAN-therm Inox and KAN-therm Copper systems is normally permissible at ambient temperature -10 °C).



However, note the additional guidance necessary for the proper submission of the installation.

KAN-therm ultraLINE:

- pay special attention to cutting tools for pipes - use only efficient pipe cutter with clean, sharp cutting blades, keep cutting perpendicularly to pipe axis,
- before expansion, pipe ends must be heated with hot water or air – pay special attention not to exceed 90 °C temperature of the pipe wall, **do not use open flame**,
- due to the increased stiffness of the multilayer pipe, it may be necessary to cut approximately 5 cm of the tip of the tube unwound from the coil (issue does not affect pipes supplied in bars).

KAN-therm Push:

- pay special attention to cutting tools for pipes - use only efficient pipe cutter with clean, sharp cutting edges, keep cutting perpendicularly to pipe axis,
- before expansion, pipe ends must be heated with hot water or air – pay special attention not to exceed 90 °C temperature of the pipe wall, **do not use open flame.**

KAN-therm ultraPRESS:

- pay special attention to pipe cutting tools - use only sharp scissors or pipe cutters with clean, sharp cutting edges, maintain cut perpendicular to pipe axis,
- perform calibration and edges chamfering of pipes for all connections (including the fittings with coloured rings),
- due to the increased stiffness of the pipes with aluminum layer, it may be necessary to cut approximately 5 cm of the tip of the tube unwound from coils (issue does not affect pipes supplied in bars).

KAN-therm PP:

- pay special attention to pipe cutting tools - use only sharp scissors or pipe cutters with clean, sharp cutting edges, maintain cut perpendicular to pipe axis,
- pay special attention not to stress mechanically Glass fibre pipes,
- secure place of welding pipes and fittings from increased movements of air masses (secure from additional cooling by wind),
- strictly comply elongated by 50% time of heating the elements while observing the degree of plasticity of the heated material,
- for PP Glass composite pipes, it is recommended to cut the end of each bar by approx. 5 cm.

KAN-therm Steel:

- protect built system against the possibility of condensation inside the elements,
- in case of necessity of the pressure test at ambient temperatures below 0 °C, carry out test only on compressed air (draining is unacceptable after the pressure test of the system). Make sure that the compressed air does not contain excessive moisture (max. 0,5 g/m³) and oil (max. 5 mg/m³).

The use of heating cables in installations constructed using KAN-therm systems.

When constructing installations in KAN-therm plastic and metal systems, the use of heating cables is permitted under the following conditions:

- the continuous temperature at the point of contact between the heating cable and the pipe does not exceed 60 °C,
- the short-term maximum temperature at the point of contact between the heating cable and the pipes must not exceed 80 °C,
- devices must be used to prevent these temperatures from being exceeded, or self-regulating heating cables must be used,
- heating cables must be secured to the pipe surfaces mechanically in a way that does not damage the pipe surfaces (e.g. plastic self-clamping cable ties) using self-adhesive aluminium tapes applied directly to the surface of KAN-therm system components,
- the heating cables and installation components used must not emit chlorides or halides.

Additionally, during the installation of all piping systems:

- read the terms of use of KAN-therm elements and installation tools,
- always avoid improper method of elements transportation or their mechanical stress,
- note the ambient environment temperature during assembly for correct calculations of thermal elongation and selection of expansion arms,
- follow the guidelines of power tools manufacturers according to the minimum operating temperature and required additional operations, it is prohibited to use power tools if water vapour condensation is possible,
- carry out pressure tests of installation using antifreeze agents – e.g. glycol-based mixtures approved by KAN Technical Support Department, in case where there is possibility of medium freezing, immediately after the test, drain the whole installation (NOTE – unacceptable for KAN-therm Steel system) or carry out pressure tests with dry compressed air (without oil content).

2 Mounting KAN-therm system pipelines

2.1 Clamps and hangers

KAN offers various types of clamps for mounting KAN-therm system pipes to structural partitions. Their structures depend on the diameter of the pipe and its construction material, the working parameters of the installation and its layout.



Clamps used in the KAN-therm system

Clamps are made of plastic or metal. Plastic clamps must be used only as shifting points for KAN-therm ultraLINE, Push, ultraPRESS and PP.

For pipelines laid in floor slabs or wall furrows, use plastic hooks and clamps with wall plugs.



Clamps for mounting KAN-therm ultraLINE, Push, ultraPRESS and PP system pipes in floor slabs

Metal grips (zinc plated steel) are equipped with elastic pads leveling out vibrations and noises. Such grips may serve as shifting points (PP) and fixed points (PS) in all KAN-therm installations with on-plaster mount. Metal clamps without elastic pads might damage the surface of plastic KAN-therm pipes or the protective zinc coating of Steel pipes, this is why they cannot be used.

In the case of KAN-therm Inox pipes, clamp pads should not contain chlorides. Do not use pipe hooks for KAN-therm Steel systems.

Shifting and fixed point clamps can't be mounted on joints.

2.2 PP shifting points

Shifting (sliding) points should allow unobstructed axial motion of pipelines (caused by the thermal elongation factor), which is why they should not be mounted next to joints (the minimal distance from the edge of a joint must be higher than the maximal elongation of the pipe section ΔL).

When changing the direction of the pipeline, a shifting point may be mounted at distance to the elbow, exceeding the length of the L_s flexible arm.

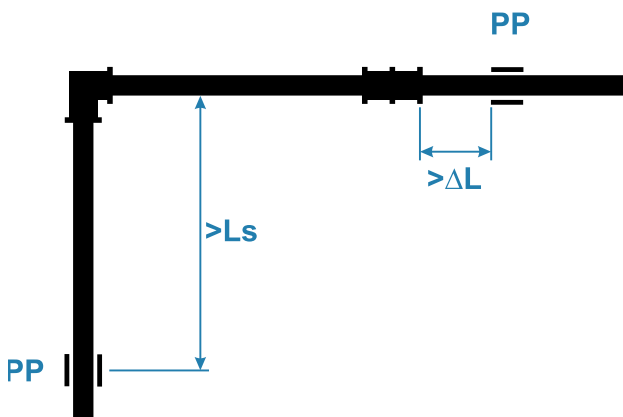

Correct location of shifting points.
 L_s – length of the flexible arm, ΔL – max elongation of the pipe section

2.3 PS fixed points

Fixed points allow pointing thermal elongations of a pipeline in a specific direction, and dividing it into smaller sections.

To form fixed points (PS) use zinc-plated steel clamps with elastic pads, ensuring precise and reliable stabilization of the pipe on its entire circumference. The clamp should fully and tightly enclose the pipe. It is acceptable to use different clamps, as long as their construction does not cause damage to installation elements and at the same time makes it possible to fasten a pipeline section permanently. The structure of clamps should allow the transfer of forces incurred by the pipe expanding and loads caused by the weight of the pipe and its content onto the clamp.

The structures mounting the clamps on structural partitions must also be strong enough to bear the above mentioned loads. To select installation slings correctly, contact their supplier.

To form a fixed point on the pipeline, use two clamps adjoining the edges of the joint (tee, connector,

coupling) or a single clamp located between two fittings adjoining to it. Fixed points are usually mounted next to pipeline of fixture branch-offs.

The assembly of a fixed point at a branch-off of a reducer is possible if the diameter of the branch-off is not smaller than one-dimension of the diameter of the main pipe.

In the case of polypropylene KAN-therm PP pipelines, use one clamp situated in between fitting couplings.

Other solution for the implementation of fixed points is also allowed, provided that the circumferential clamping force ensures no axial movement of the pipelines while at the same time securing the installation pipes against mechanical damage.

The arrangement of fixed points results from the adopted solution of thermal elongation compensation of the installation and should be included in the technical design.

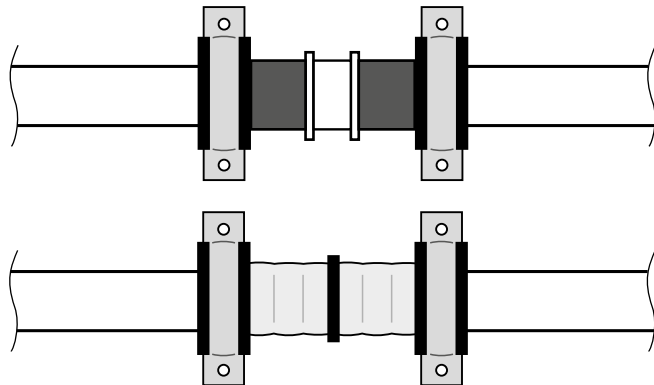

Example of execution of a fixed point on a straight section of a KAN-therm ultraLINE, ultraPRESS, Push system pipeline

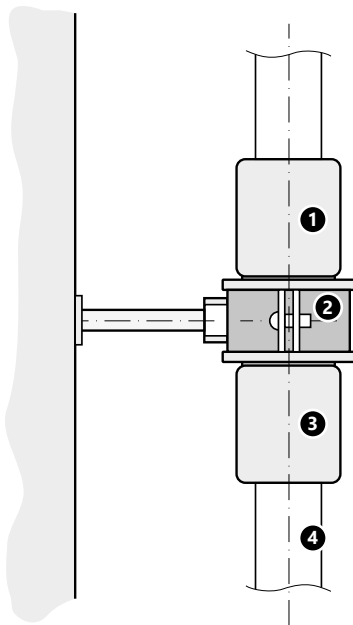

Example of execution of a fixed point on a straight section of a KAN-therm PP system pipeline

1. coupling
2. clamp
3. coupling
4. pipe

D2 ≥ D1

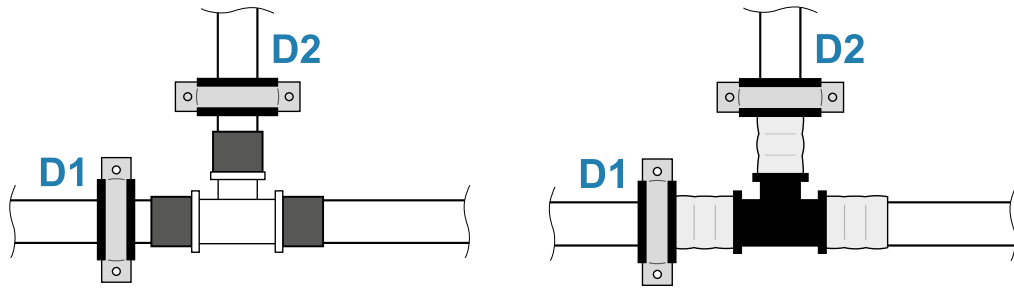

Example of execution of a fixed point next to a branch-off of a KAN-therm ultraLINE, ultraPRESS, Push system pipeline

D2 < D1

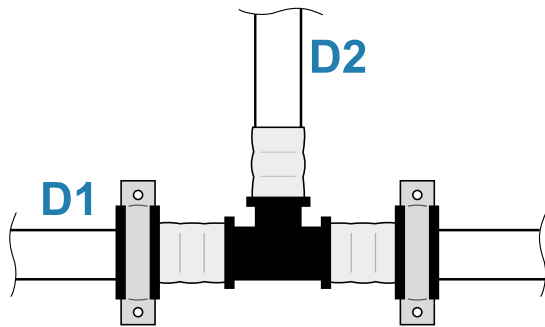

Example of execution of a fixed point next to a branch-off of a KAN-therm ultraLINE, ultraPRESS and Push system pipeline

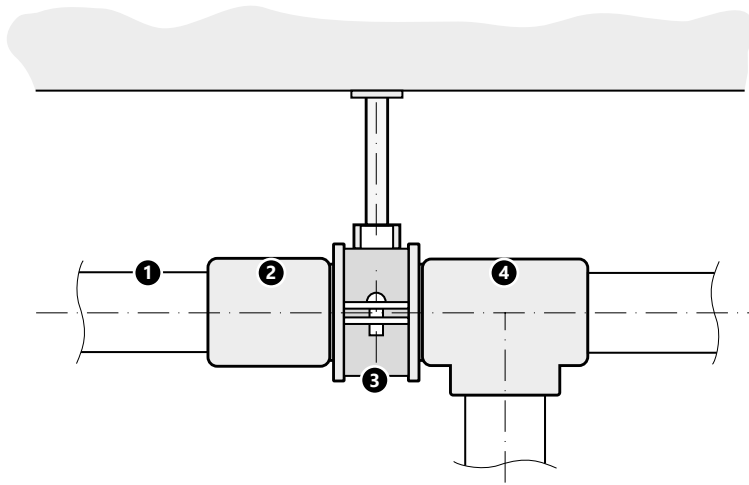

Example of execution of a fixed point next to a branch-off of a KAN-therm PP system pipeline

- 1. pipe
- 2. coupling
- 3. clamp
- 4. three-way

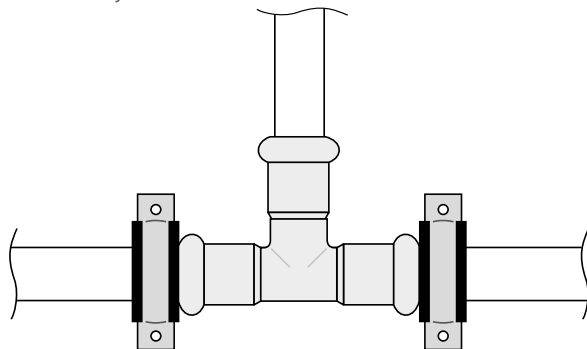

Example of execution of a fixed point next to a branch-off of a KAN-therm Steel/Inox/Copper.

2.4 Passages through building partitions.

Passages through building partitions that do not separate fire zones.

Pipes passing through building partitions which do not separate fire zones, made of KAN-therm system components (ultraLINE, Push, ultraPRESS, PP, PP Green, Steel, Steel XPress Sprinkler, Inox, Inox XPress Sprinkler as well as Copper and Copper Gas), should be routed in protective sleeves in a way preventing mechanical damage to the system components, including their external surfaces.

The protective sleeves should be made of plastic or metal pipes and the gap should be filled with a permanently flexible material which will not damage the installation components (e.g. closed-pore moisture-proof insulation).

The inner diameter of the protective sleeve should be at least 10 mm larger than the diameter of the carrier pipe, at least 20 mm longer than the finished partition.

Surfaces of KAN-therm Steel system pipes passing through protective sleeves filled with permanently flexible material should be protected with an additional coat of paint. For this purpose use water-soluble acrylic paints recommended for the material from which KAN-therm Steel pipes are made. The area of additional paint coating of KAN-therm Steel pipes must be larger than the length of protective sleeve. Such protection should be made along the pipe length with an allowance of at least 10 mm on each side of the protective sleeve.

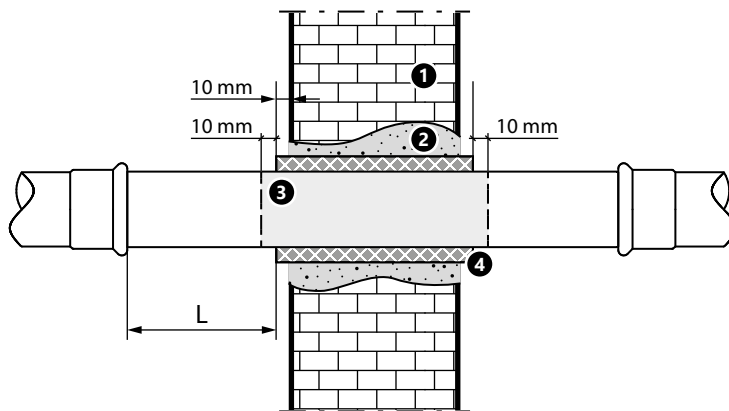

1. Building partition which does not separate fire zones
2. Cement mortar filling
3. The area of corrosion protection of the outer surface of the pipe in the form of a paint coating.
4. Full damp-proof or moisture-proof thermal insulation made of closed-pore material with an external foil facing placed in protective sleeve.

Notice: The length L must be LARGER than the thermal elongation of the pipe section. The length L also must allow correct attaching the press jaws onto the fitting.

Passages through building partitions that separate fire zones.

Detailed requirements for passages (installation conduits) through building partitions that separate fire zones are determined by local standards and regulations in force in a specific country, which must be followed.

Passages through walls and ceilings which are elements of fire separation, for steel pipelines made in the KAN-therm System (Steel, Steel XPress Sprinkler, Inox, Inox XPress Sprinkler, Copper, Cooper Gas) should be made of non-flammable materials, using fireproof acrylic compounds, and other technical solutions available on the market, in accordance with guidelines given in approval documentation (technical approvals, National Technical Assessments) and technical documentation of the solutions manufacturer.



Note: silicone and cement-based compounds are not allowed to be used in direct contact with KAN-therm Steel / Steel XPress Sprinkler pipes. These substances can cause damage to the seals and surface of the pipe. In this case, a paint coating must be applied to the pipes. Use only water-based paints.

Surfaces of KAN-therm Steel and Steel XPress Sprinkler system pipes passing through building partitions constituting separation of fire zones (filled with fireproofing compounds), should be protected against corrosion (e.g., with a paint coating). For this purpose, water-soluble acrylic paints (recommended for the material from which KAN-therm Steel and Steel XPress Sprinkler pipes are made) should be used. The area of protecting KAN-therm Steel and Steel XPress Sprinkler pipes with additional paint coating must be larger than the thickness of the building partition and the area of filling with fire retardant compound. Such protection must be carried out along the pipe length with an allowance of at least 10 mm on each side of the building partition and the surface protected with the fire retardant compound.

Passages through walls and ceilings that are elements of fire separation for plastic pipelines manufactured in the KAN-therm system (ultraLINE, Push, Press, ultraPRESS, PP and PP Green) must be made using ready solutions available on the market for plastic pipes, e.g. materials with intumescent coating. The penetration should be made in accordance with the guidelines given in approval documentation (technical approvals, National Technical Assessments) and the technical documentation of the manufacturer of such solutions.



Notice:

Passages through walls and ceilings which are elements of fire separation, must be protected from the negative effects (especially mechanical damage) of pipe movements, both longitudinal and transverse, resulting from their thermal expansion.

For this purpose, fixed points should be used on both sides of the passage on the pipelines. Clamps that work as fixed points should be fixed in close proximity to the passage/partition (L), ensuring their technically correct installation. L - depending on the diameter of the pipeline, this is the distance that allows for the correct installation of the fixed point and allows the clamping jaws to be fixed for the proper pressing of the fitting.

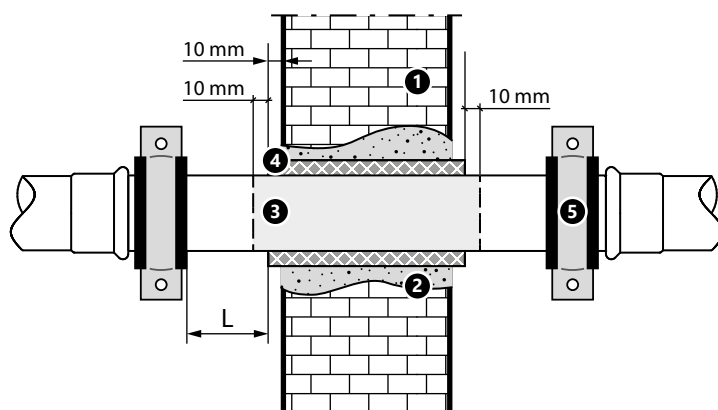

1. Building partition which is a separation of fire zones.
2. Filling from non-flammable materials, using fire-resistant acrylic masses, in accordance with the guidelines given in the approval documentation (technical approvals, National Technical Assessments) and technical documentation of the manufacturer of the filling mass.
3. Area of corrosion protection of the external surface of the pipe in the form of a paint coating.
4. Full, sealed damp-proof or thermal, non-absorbent insulation of closed-cell material, equipped with an external foil coating. It has to be made in accordance with fire regulations.
5. Clamp - fixed point.

2.5 Support spans

Maximum distances between supports for KAN-therm system pipelines conducted at the surface of structural partitions and structures are provided in the tables. Fixed points, shifting points and passages through structural partitions in protective sleeves are considered supports.

Maximum support span [m] PERTAL² ultraLINE pipes with aluminum layer

Pipe layout	External pipe diameter [mm]			
	16	20	25	32
vertically	1,5	1,7	1,9	2,1
horizontally	1,2	1,3	1,5	1,6

Maximum support span [m] PERT², PEXC ultraLINE pipes with EVOH layer

Pipe layout	External pipe diameter [mm]		
	14	16	20
vertically	0,5	0,6	0,7
horizontally	0,4	0,5	0,6

Maximum support span [m] KAN-therm ultraPRESS pipes with aluminum layer

Pipe layout	External pipe diameter [mm]							
	14	16	20	25/26	32	40	50	63
vertically	1,5	1,5	1,7	1,9	2,1	2,2	2,6	2,8
horizontally	1,2	1,2	1,3	1,5	1,6	1,7	2,0	2,2

Maximum support span [m] KAN-therm Push PERT, PEXC pipes with EVOH layer

Pipe layout	External pipe diameter [mm]				
	12	14	18	25	32
vertically	1,0 (0,5)	1,0 (0,5)	1,0 (0,7)	1,2 (0,8)	1,3 (0,9)
horizontally	0,8 (0,4)	0,8 (0,4)	0,8 (0,5)	0,8 (0,6)	1,0 (0,7)

In brackets values for hot water

Maximum support span [m] KAN-therm PP PPR (uniform) pipes

Medium temp. [°C]	External pipe diameter [mm]									
	16	20	25	32	40	50	63	75	90	110
20	0,50	0,60	0,75	0,90	1,00	1,20	1,40	1,50	1,60	1,80
30	0,50	0,60	0,75	0,90	1,00	1,20	1,40	1,50	1,60	1,80
40	0,50	0,60	0,70	0,80	0,90	1,10	1,30	1,40	1,50	1,70
50	0,50	0,60	0,70	0,80	0,90	1,10	1,30	1,40	1,50	1,70
60	0,50	0,55	0,65	0,75	0,85	1,00	1,15	1,25	1,40	1,60
80	0,50	0,50	0,60	0,70	0,80	0,95	1,05	1,15	1,25	1,40

For vertical pipeline sections, support span may be increased by 30%

Maximum support span [m] KAN-therm PP stabiGLASS PPR pipes

Medium temp. [°C]	External pipe diameter [mm]									
	20	25	32	40	50	63	75	90	110	
0	1,20	1,40	1,60	1,80	2,05	2,30	2,45	2,60	2,90	
20	0,90	1,05	1,20	1,35	1,55	1,75	1,85	1,95	2,15	
30	0,90	1,05	1,20	1,35	1,55	1,75	1,85	1,95	2,10	
40	0,85	0,95	1,10	1,25	1,45	1,65	1,75	1,85	2,00	
50	0,85	0,95	1,10	1,25	1,45	1,65	1,75	1,85	1,90	
60	0,80	0,90	1,05	1,20	1,35	1,55	1,65	1,75	1,80	
70	0,70	0,80	0,95	1,10	1,30	1,45	1,55	1,65	1,70	

For vertical pipeline sections, support span may be increased by 30%

Maximum support span [m] KAN-therm Steel/Inox pipes

Pipe layout	External pipe diameter [mm]													
	15	18	22	28	35	42	54	64	66,7	76,1	88,9	108	139	168
vertically/ horizontally	1,25	1,50	2,00	2,25	2,75	3,00	3,50	3,75	4	4,25	4,75	5,00	5,00	5,00

Maximum support span for pipes KAN-therm Steel/Inox

Maximum support span [m] Copper pipes

Pipe layout	External pipe diameter [mm]											
	12	15	18	22	28	35	42	54	66.7	76.1	88.9	108
vertically/ horizontally	1,0	1,3	1,5	2,0	2,3	2,8	3,0	3,5	4,3	4,3	4,8	5,0

3 Compensation of thermal elongation of pipelines

3.1 Linear thermal elongation

Under the influence of temperature resulting from medium and ambient temperature drops, installation pipelines are expanded or shortened linearly during assembly (causing an axial motion of pipelines).

Vulnerability of pipes to linear elongation is defined by the thermal elongation coefficient α . Elongation (or shortening) of a pipeline section ΔL is calculated according to the following formula:

$$\Delta L = \alpha \times L \times \Delta t$$

ΔL	change in pipe length	[mm]
α	elongation coefficient	[mm/m \times K]
L	initial pipeline length	[m]
Δt	temperature difference: working temp. and assembly temp. of the pipeline	[K]

Value of coefficient α for KAN-therm pipes		
KAN-therm ultraLINE, PERT², PEXC pipes	$\alpha = 0,18$	[mm/m \times K]
KAN-therm ultraLINE, PERTAL² pipes	$\alpha = 0,025$	[mm/m \times K]
KAN-therm Push, PERT, PEXC pipes	$\alpha = 0,18$	[mm/m \times K]
KAN-therm ultraPRESS, PERTAL	$\alpha = 0,025$	[mm/m \times K]
KAN-therm PP, PPR uniform pipes	$\alpha = 0,15$	[mm/m \times K]
KAN-therm PP, stabiGLASS PPR pipes	$\alpha = 0,05$	[mm/m \times K]
KAN-therm Steel, carbon steel pipes	$\alpha = 0,0108$	[mm/m \times K]
KAN-therm Inox, stainless steel pipes	$\alpha = 0,0160$	[mm/m \times K]
KAN-therm Copper, copper pipes	$\alpha = 0,017$	[mm/m \times K]

Changes in pipe length may be calculated basing on data included in one of the following tables.

Thermal elongation of PERTAL² and PERTAL pipes

L [m]	Linear elongation ΔL [mm] PERTAL ² , PERTAL									
	Δt [K]									
	10	20	30	40	50	60	70	80	90	100
1	0,25	0,50	0,75	1,00	1,25	1,50	1,75	2,00	2,25	2,50
2	0,50	1,00	1,50	2,00	2,50	3,00	3,50	4,00	4,50	5,00
3	0,75	1,50	2,25	3,00	3,75	4,50	5,25	6,00	6,75	7,50
4	1,00	2,00	3,00	4,00	5,00	6,00	7,00	8,00	9,00	10,00
5	1,25	2,50	3,75	5,00	6,25	7,50	8,75	10,00	11,25	12,50
6	1,50	3,00	4,50	6,00	7,50	9,00	10,50	12,00	13,50	15,00
7	1,75	3,50	5,25	7,00	8,75	10,50	12,25	14,00	15,75	17,50
8	2,00	4,00	6,00	8,00	10,00	12,00	14,00	16,00	18,00	20,00
9	2,25	4,50	6,75	9,00	11,25	13,50	15,75	18,00	20,25	22,50
10	2,50	5,00	7,50	10,00	12,50	15,00	17,50	20,00	22,50	25,00

Thermal elongation of PERT² pipes with EVOH layer and PEXC KAN-therm ultraLINE

L [m]	Linear elongation ΔL [mm] PERT ² , PEXC pipes									
	Δt [K]									
	10	20	30	40	50	60	70	80	90	100
1	1,8	3,6	5,4	7,2	9,0	10,8	12,6	14,4	16,2	18,0
2	3,6	7,2	10,8	14,4	18,0	21,6	25,2	28,8	32,4	36,0
3	5,4	10,8	16,2	21,6	27,0	32,4	37,8	43,2	48,6	54,0
4	7,2	14,4	21,6	28,8	36,0	43,2	50,4	57,6	64,8	72,0
5	9,0	18,0	27,0	36,0	45,0	54,0	63,0	72,0	81,0	90,0
6	10,8	21,6	32,4	43,2	54,0	64,8	75,6	86,4	97,2	108,0
7	12,6	25,2	37,8	50,4	63,0	75,6	88,2	100,8	113,4	126,0
8	14,4	28,2	43,2	57,6	72,0	88,2	100,8	115,2	129,6	144,0
9	16,2	32,4	48,6	64,8	81,0	97,2	113,4	129,6	145,8	162,0
10	18,0	36,0	54,0	72,0	90,0	100,8	126,0	144,0	162,0	180,0

Thermal elongation of KAN-therm PP PPR (uniform) pipes

L [m]	Wydłużenie liniowe ΔL [mm] Rury KAN-therm PP									
	Δt [K]									
	10	20	30	40	50	60	70	80	90	100
1	1,5	3,0	4,5	6,0	7,5	9,0	10,5	12,0	13,5	15,0
2	3,0	6,0	9,0	12,0	15,0	18,0	21,0	24,0	27,0	30,0
3	4,5	9,0	13,5	18,0	22,5	27,0	31,5	36,0	40,5	45,0
4	6,0	12,0	18,0	24,0	30,0	36,0	42,0	48,0	54,0	60,0
5	7,5	15,0	22,5	30,0	37,5	45,0	52,5	60,0	67,5	75,0
6	9,0	18,0	27,0	36,0	45,0	54,0	63,0	72,0	81,0	90,0
7	10,5	21,0	31,5	42,0	52,5	63,0	73,5	84,0	94,5	105,0
8	12,0	24,0	36,0	48,0	60,0	72,0	84,0	96,0	108,0	120,0
9	13,5	27,0	40,5	54,0	67,5	81,0	94,5	108,0	121,5	135,0
10	15,0	30,0	45,0	60,0	75,0	90,0	105,0	120,0	135,0	150,0

Thermal elongation of KAN-therm PP stabiGLASS PPR pipes

L [m]	Linear elongation ΔL [mm] KAN-therm PP stabiGLASS PPR pipes									
	Δt [K]									
	10	20	30	40	50	60	70	80	90	100
1	0,5	1,0	1,5	2,0	2,5	3,0	3,5	4,0	4,5	5,0
2	1,0	2,0	3,0	4,0	5,0	6,0	7,0	8,0	9,0	10,0
3	1,5	3,0	4,5	6,0	7,5	9,0	10,5	12,0	13,5	15,0
4	2,0	4,0	6,0	8,0	10,0	12,0	14,0	16,0	18,0	20,0
5	2,5	5,0	7,5	10,0	12,5	15,0	17,5	20,0	22,5	25,0
6	3,0	6,0	9,0	12,0	15,0	18,0	21,0	24,0	27,0	30,0
7	3,5	7,0	10,5	14,0	17,5	21,0	24,5	28,0	31,5	35,0
8	4,0	8,0	12,0	16,0	20,0	24,0	28,0	32,0	36,0	40,0
9	4,5	9,0	13,5	18,0	22,5	27,0	31,5	36,0	40,5	45,0
10	5,0	10,0	15,0	20,0	25,0	30,0	35,0	40,0	45,0	50,0

Thermal elongation of KAN-therm Steel pipes

L [m]	Linear elongation ΔL [mm] KAN-therm Steel pipes									
	Δt [K]									
	10	20	30	40	50	60	70	80	90	100
1	0,11	0,22	0,32	0,43	0,54	0,65	0,76	0,86	0,97	1,08
2	0,22	0,43	0,65	0,86	1,08	1,30	1,51	1,73	1,94	2,16
3	0,32	0,65	0,97	1,30	1,62	1,94	2,27	2,59	2,92	3,24
4	0,43	0,86	1,30	1,73	2,16	2,59	3,02	3,46	3,89	4,32
5	0,54	1,08	1,62	2,16	2,70	3,24	3,78	4,32	4,86	5,40
6	0,65	1,30	1,94	2,59	3,24	3,89	4,54	5,18	5,83	6,48
7	0,76	1,51	2,27	3,02	3,78	4,54	5,29	6,05	6,80	7,56
8	0,86	1,73	2,59	3,46	4,32	5,18	6,05	6,91	7,78	8,64
9	0,97	1,94	2,92	3,89	4,86	5,83	6,80	7,78	8,75	9,72
10	1,08	2,16	3,24	4,32	5,40	6,48	7,56	8,64	9,72	10,80
12	1,30	2,59	3,89	5,18	6,48	7,78	9,07	10,37	11,66	12,96
14	1,51	3,02	4,54	6,05	7,56	9,07	10,58	12,10	13,61	15,12
16	1,73	3,46	5,18	6,91	8,64	10,37	12,10	13,82	15,55	17,28
18	1,94	3,89	5,83	7,78	9,72	11,66	13,61	15,55	17,50	19,44
20	2,16	4,32	6,48	8,64	10,80	12,96	15,12	17,28	19,44	21,60

Thermal elongation of KAN-therm Inox pipes

L [m]	Linear elongation ΔL [mm] KAN-therm Inox pipes									
	Δt [K]									
	10	20	30	40	50	60	70	80	90	100
1	0,16	0,32	0,48	0,64	0,80	0,96	1,12	1,28	1,44	1,60
2	0,32	0,64	0,96	1,28	1,60	1,92	2,24	2,56	2,88	3,20
3	0,48	0,96	1,44	1,92	2,40	2,88	3,36	3,84	4,32	4,80
4	0,64	1,28	1,92	2,56	3,20	3,84	4,48	5,12	5,76	6,40
5	0,80	1,60	2,40	3,20	4,00	4,80	5,60	6,40	7,20	8,00
6	0,96	1,92	2,88	3,84	4,80	5,76	6,72	7,68	8,64	9,60
7	1,12	2,24	3,36	4,48	5,60	6,72	7,84	8,96	10,08	11,20
8	1,28	2,56	3,84	5,12	6,40	7,68	8,96	10,24	11,52	12,80
9	1,44	2,88	4,32	5,76	7,20	8,64	10,08	11,52	12,96	14,40
10	1,60	3,20	4,80	6,40	8,00	9,60	11,20	12,80	14,40	16,00
12	1,92	3,84	5,76	7,68	9,60	11,52	13,44	15,36	17,28	19,20
14	2,24	4,48	6,72	8,96	11,20	13,44	15,68	17,92	20,16	22,40
16	2,56	5,12	7,68	10,24	12,80	15,36	17,92	20,48	23,04	25,60
18	2,88	5,76	8,64	11,52	14,40	17,28	20,16	23,04	25,92	28,80
20	3,20	6,40	9,60	12,80	16,00	19,20	22,40	25,60	28,80	32,00

Thermal elongation of copper pipes

L [m]	Linear elongation ΔL [mm] copper pipes									
	Δt [K]									
	10	20	30	40	50	60	70	80	90	100
1	0,17	0,34	0,51	0,68	0,85	1,02	1,19	1,36	1,53	1,70
2	0,34	0,68	1,02	1,36	1,70	2,04	2,38	2,72	3,06	3,40
3	0,51	1,02	1,53	2,04	2,55	3,06	3,57	4,08	4,59	5,10
4	0,68	1,36	2,04	2,72	3,40	4,08	4,76	5,44	6,12	6,80
5	0,85	1,70	2,55	3,40	4,25	5,10	5,95	6,80	7,65	8,50
6	1,02	2,04	3,06	4,08	5,10	6,12	7,14	8,16	9,18	10,20
7	1,19	2,38	3,57	4,76	5,95	7,14	8,33	9,52	10,71	11,90
8	1,36	2,72	4,08	5,44	6,80	8,16	9,52	10,88	12,24	13,60
9	1,53	3,06	4,59	6,12	7,65	9,18	10,71	12,24	13,77	15,30
10	1,70	3,40	5,10	6,80	8,50	10,20	11,90	13,60	15,30	17,00
12	2,04	4,08	6,12	8,16	10,20	12,24	14,28	16,32	18,36	20,40
14	2,38	4,76	7,14	9,52	11,90	14,28	16,66	19,04	21,42	23,80
16	2,72	5,44	8,16	10,88	13,60	16,32	19,04	21,76	24,48	27,20
18	3,06	6,12	9,18	12,24	15,30	18,36	21,42	24,28	27,54	30,60
20	3,40	6,80	10,20	13,60	17,00	20,40	23,80	27,20	30,60	34,00

3.2 Compensation of elongations

Flexible arm

Thermal elongation of pipelines in installations is an undesirable phenomenon which has negative impact on the operation and durability, as well as the outer appearance of the installation.

Therefore, as early as in the stage of designing an installation, you should assume specific compensation solutions, consisting of various compensators and properly arranged fixed and shifting points.

In on-plaster installations, redirecting the installation with the use of flexible (elastic) arms is used to compensate for the loads of thermal elongation. Tensions resulting from thermal elongation are transferred onto the arm, causing it to bend slightly.

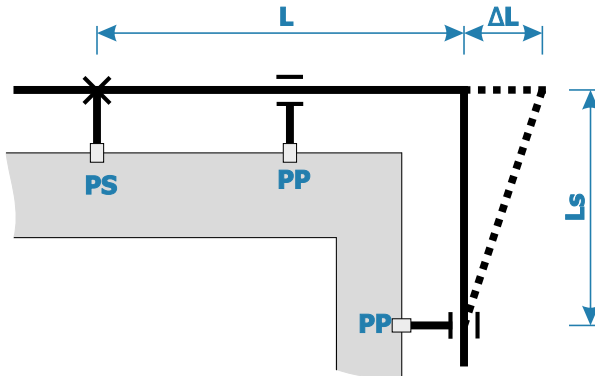

Pipe material constant for KAN-therm pipes

KAN-therm ultraLINE PERTAL ² / ultraPRESS PERTAL pipes with aluminum layer	33
KAN-therm ultraLINE (PEXC, PERT ²) KAN-therm Push (PEXC and PERT)	15
KAN-therm stabiGLASS PPR	30
KAN-therm stabiAL PPR	20
KAN-therm Steel/Inox	45
KAN-therm Copper	35

The required length of the flexible arm L_s is calculated in the following way:

$$L_s = k \times \sqrt{D \times \Delta L}$$

Where:

L_s – length of the flexible arm [mm],

k – pipe material constant,

D – external pipe diameter [mm],

ΔL – change in pipe length [mm].

Determine the length of the L_s arm basing on the tables below.

Length of the L_s flexible arm for KAN-therm pipes with aluminum layer [mm]

Elongation ΔL [mm]	External pipe diameter D [mm]								
	14	16	20	25	26	32	40	50	63
5	301	322	360	402	410	455	509	569	639
10	426	455	509	569	580	644	720	805	904
15	522	558	624	697	711	789	882	986	1107
20	602	644	720	805	821	911	1018	1138	1278
30	738	789	882	986	1005	1115	1247	1394	1565
40	852	911	1018	1138	1161	1288	1440	1610	1807
50	952	1018	1138	1273	1298	1440	1610	1800	2020
60	1043	1115	1247	1394	1422	1577	1764	1972	2213
70	1127	1205	1347	1506	1536	1704	1905	2130	2391
80	1205	1288	1440	1610	1642	1821	2036	2277	2556
90	1278	1366	1527	1708	1741	1932	2160	2415	2711
100	1347	1440	1610	1800	1836	2036	2277	2546	2857

Length of the Ls flexible arm for KAN-therm PEXC and PERT pipes [mm]

Elongation ΔL [mm]	External pipe diameter D [mm]						
	12	14	16	18	20	25	32
5	116	125	134	142	150	168	190
10	164	177	190	201	212	237	268
15	201	217	232	246	260	290	329
20	232	251	268	285	300	335	379
30	285	307	329	349	367	411	465
40	329	355	379	402	424	474	537
50	367	397	424	450	474	530	600
60	402	435	465	493	520	581	657
70	435	470	502	532	561	627	710
80	465	502	537	569	600	671	759
90	493	532	569	604	636	712	805
100	520	561	600	636	671	750	849

Length of the Ls flexible arm for KAN-therm PP [mm]

Elongation ΔL [mm]	External pipe diameter D [mm]									
	16	20	25	32	40	50	63	75	90	110
5	179	200	224	253	283	316	355	387	424	469
10	253	283	316	358	400	447	502	548	600	663
15	310	346	387	438	490	548	615	671	735	812
20	358	400	447	506	566	632	710	775	849	938
30	438	490	548	620	693	775	869	949	1039	1149
40	506	566	632	716	800	894	1004	1095	1200	1327
50	566	632	707	800	894	1000	1122	1225	1342	1483
60	620	693	775	876	980	1095	1230	1342	1470	1625
70	669	748	837	947	1058	1183	1328	1449	1587	1755
80	716	800	894	1012	1131	1265	1420	1549	1697	1876
90	759	849	949	1073	1200	1342	1506	1643	1800	1990
100	800	894	1000	1131	1265	1414	1587	1732	1897	2098
150	980	1095	1225	1386	1549	1732	1944	2121	2324	2569
200	1131	1265	1414	1600	1789	2000	2245	2449	2683	2966

In the KAN-therm PP system, you may also use ready-made loop compensators with 150 mm loop diameters:

Nominal compensator diameter [mm]	Thermal elongation value possible to compensate [mm]
16	80
20	70
25	60
32	50



Length of the Ls flexible arm for KAN-therm Steel/Inox pipes [mm]

Elongation ΔL [mm]	External pipe diameter [mm]												
	12	15	18	22	28	35	42	54	64	66,7	76,1	88,9	108
2	220	246	270	298	337	376	412	468	509	520	555	600	661
4	312	349	382	422	476	532	583	661	720	735	785	849	935
6	382	427	468	517	583	652	714	810	882	900	962	1039	1146
8	441	493	540	597	673	753	825	935	1018	1039	1110	1200	1323
10	493	551	604	667	753	842	922	1046	1138	1162	1241	1342	1479
12	540	604	661	731	825	922	1010	1146	1247	1273	1360	1470	1620
14	583	652	714	790	891	996	1091	1237	1347	1375	1469	1588	1750
16	624	697	764	844	952	1065	1167	1323	1440	1470	1570	1697	1871
18	661	739	810	895	1010	1129	1237	1403	1527	1559	1665	1800	1984
20	697	779	854	944	1065	1191	1304	1479	1610	1644	1756	1897	2091
25	731	871	955	1055	1191	1331	1458	1653	1800	1724	1963	2121	2338
30	764	955	1046	1156	1304	1458	1597	1811	1972	1800	2150	2324	2561
35	795	1031	1129	1249	1409	1575	1725	1956	2130	1874	2322	2510	2767
40	825	1102	1207	1335	1506	1684	1844	2091	2274	1945	2483	2683	2958
45	854	1169	1281	1416	1597	1786	1956	2218	2415	2013	2633	2846	3137
50	882	1232	1350	1492	1684	1882	2062	2338	2546	2079	2776	3000	3307

Length of the Ls flexible arm for copper pipes [mm]

Elongation ΔL [mm]	External pipe diameter [mm]												
	12	15	18	22	28	35	42	54	66,7	76,1	88,9	108	
2	171	192	210	232	262	293	321	364	404	432	467	514	
4	242	271	297	328	370	414	454	514	572	611	660	727	
6	297	332	364	402	454	507	556	630	700	748	808	891	
8	343	383	420	464	524	586	642	727	808	864	933	1029	
10	383	429	470	519	586	655	717	813	904	966	1044	1150	
12	420	470	514	569	642	717	786	891	990	1058	1143	1260	
14	454	507	556	614	693	775	849	962	1070	1142	1235	1361	
16	485	542	594	657	741	828	907	1029	1143	1221	1320	1455	
18	514	575	630	696	786	878	962	1091	1213	1295	1400	1543	
20	542	606	664	734	828	926	1014	1150	1278	1365	1476	1627	
25	606	678	742	821	926	1035	1134	1286	1429	1527	1650	1819	
30	664	742	813	899	1014	1134	1242	1409	1566	1672	1808	1992	
35	717	802	878	971	1096	1225	1342	1522	1691	1806	1952	2152	
40	767	857	939	1038	1171	1310	1435	1627	1808	1931	2087	2300	
45	813	909	996	1101	1242	1389	1522	1725	1918	2048	2214	2440	
50	857	959	1050	1161	1310	1464	1604	1819	2021	2159	2333	2572	

Knowledge of the length of the Ls flexible arm is vital when assembling secure branch-offs on a pipeline subjected to elongation (and when there is no fixed point on the branch-off). Applying a too short Ls section will cause excessive tensions in the vicinity of the tee and, in extreme case, may damage the joint (see point "Assembly of installation riser").

When planning a flexible arm (L_s), remember that its length should be lower than the maximum distance occurring between the clamps for a given pipeline diameter.

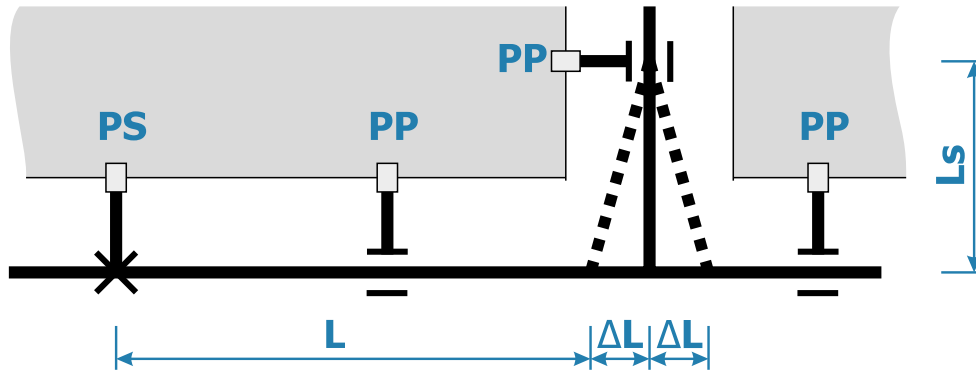

Making a flexible arm on a branch-off

3.3 Compensators in KAN-therm system installations

Z-type compensator

Various types of compensators are used to eliminate the effects of thermal elongations of pipelines. Compensators presented here utilize the action of the flexible arm. If there is a possibility of shifting the axis of the pipeline, you may use a Z-type compensator.

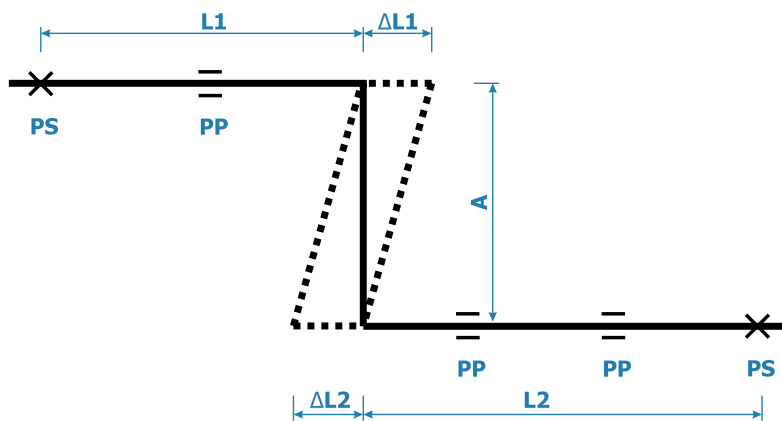

Type Z compensator

To calculate the length of the flexible arm $A = L_s$ of the compensator, assume $L_z = L_1 + L_2$ as the replacement length. For this length, calculate the elongation ratio ΔL (from the template in the table) and then the value of L_s (from the template in the table). The length of arm A must not exceed the maximal span of mounts for a given pipeline diameter. Do not mount any clamps on it.

U-type compensator

If it is impossible to compensate pipeline elongation by changing the route direction (the pipeline axis runs along one line along the entire length), an U-type compensator should be used.

Calculate the length of compensator arm A according to formula or data in the tables for determining the length of flexible arm, assuming that $A = L_s$.

If the distances from the middle of the compensator to the nearest **PS** fixed points are not the same, assume the elongation ratio ΔL of the longer pipeline section, on which the compensator is mounted to determine the length of the arm A (in the figure, elongation ratio ΔL_2 corresponds to section L_2). The most optimal solution is to place the compensator in the middle of the pipeline section ($L_1 = L_2$).

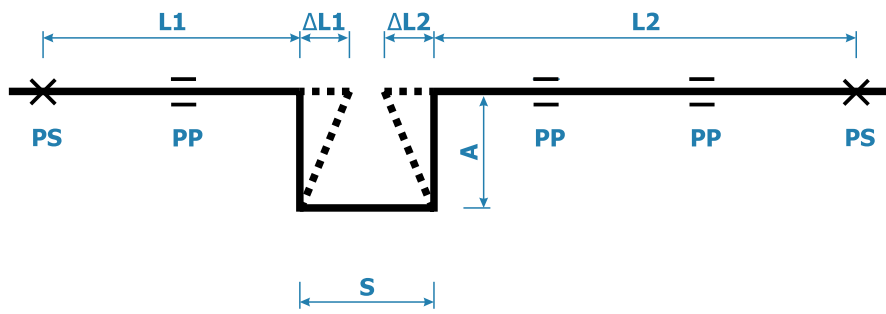

U-type compensator with fixed point

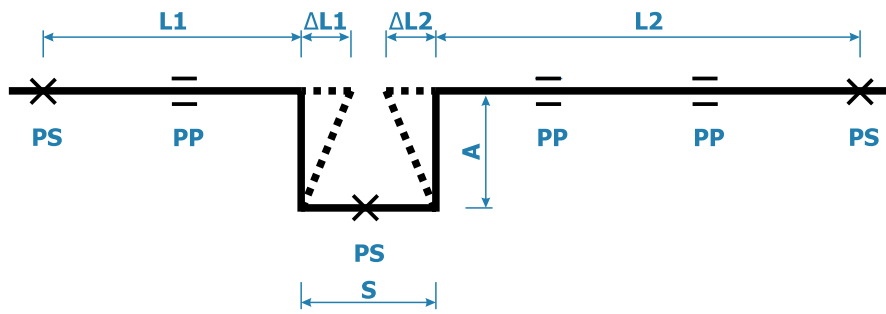

U-type compensator

When dimensioning the compensator, follow these principles:

You can build a U-shaped compensator using four 90-degree system elbows and pipe sections.

In the case of KAN-therm ultraLINE pipes with aluminum layer and KAN-therm ultraPRESS, build the compensator by bending the pipe suitably, maintaining the minimum radius: $R = 5 \times De$ (do not bend pipes with diameters exceeding 32 mm).

The minimal width of a compensator S must ensure unobstructed operation of the arms of compensated sections $L1$ and $L2$ and take into account possible thickness of thermal coating (gizol) for the pipeline.

You may assume that:

$$S = 2 \times g_{\text{izol}} + \Delta L1 + \Delta L2 + S_{\text{min}}$$

$$S_{\text{min}} = 150 - 200 \text{ mm}$$

g_{izol} – insulation thickness

For Steel/Inox steel pipes, assume that:

$$S = \frac{1}{2} A$$

The length of the compensator should not exceed the maximum span of mounts for a given pipeline diameter. Do not mount any clamps on the arms.

Bellows compensators for KAN-therm Steel/Inox steel pipe installations

It is recommended to design and perform natural (geometric) compensation in all possible cases.

If there is no possibility of compensating for steel pipeline elongations through the use of flexible arms (type L, Z or U compensator), you can also use available axis bellows compensators.

Material and application

KAN-therm Inox axial bellow compensators are made of stainless steel grade 1.4404 and intended for the construction of internal, closed, pressurized heating and chilled water installations.



Note: The possibility of using compensators in drinking water installations depends on regulations applicable in the country. Each time, check if the relevant "certificates" are available.

Design and technical specifications

The compensators are equipped with press ending (15–54 mm) or plain pipe ending (76,1–108 mm). The connections are achieved by three-point "M" profile radial pressing.

Compensators Ø15–54 mm

Material	1.4404 (AISI 316L)						
Seal	EPDM70						
T_{work}	135 °C						
T_{max}	150 °C						
P_{max}	16 bar						
Crimping profile	M						
d1 = d2	15 mm	18 mm	22 mm	28 mm	35 mm	42 mm	54 mm
D1 = D2	24 mm	27 mm	32 mm	38 mm	45 mm	54 mm	65 mm
a	24 mm	27 mm	37 mm	44 mm	50 mm	60 mm	72 mm
l	70 mm	66 mm	78 mm	84 mm	88 mm	94 mm	110 mm
L	110 mm	106 mm	120 mm	130 mm	140 mm	154 mm	180 mm
Max. elongation to compensate Δl	14 mm	16 mm	20 mm	22 mm	24 mm	24 mm	30 mm
Effective area [cm²]	3,1	4,0	7,2	10,5	13,9	20,4	31,0
Spring rate [N/mm]	28	28	40	42	54	47	48
Weight	0,05 kg	0,07 kg	0,13 kg	0,16 kg	0,24 kg	0,31 kg	0,46 kg

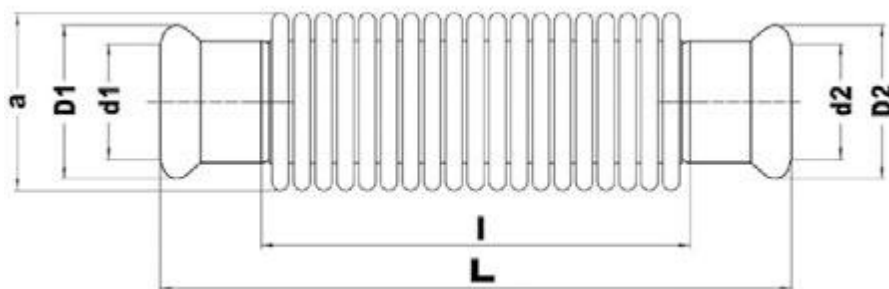

Compensators Ø76,1-108 mm

Material	1.4404 (AISI 316L)		
T_{work}	135 °C		
T_{max}	150 °C		
P_{max}	16 bar		
d1 = d2	76,1 mm	88,9 mm	108 mm
a	92 mm	106 mm	130 mm
es1 = es2	55 mm	63 mm	77 mm
L	276 mm	290 mm	346 mm
Elongation take-over Δl	30 mm	30 mm	30 mm
Effective area [cm²]	52,5	73,2	115,0
Spring rate [N/mm]	60	82	92
Weight	1,41 kg	1,61 kg	2,10 kg

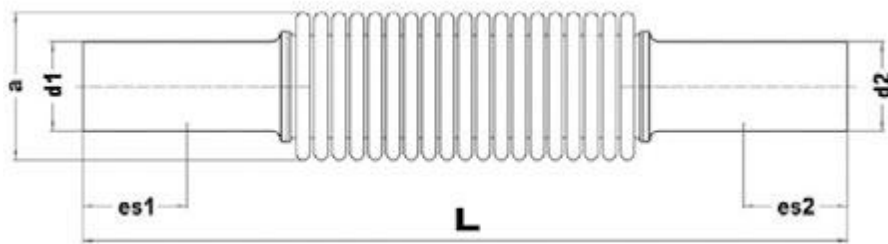

Designation

The KAN-therm Inox compensators are intended for compensating thermal elongations of KAN-therm Steel and KAN-therm Inox pipelines.

Recommendations of application

- The design of compensators is based on the elastic bellows, which rigidity is smaller than the rigidity of the compensated pipelines. This requires an assembly only at straight sections, anchored on two sides by fixed supports.
- The compensators cannot be mounted on bends and other self-compensating sections.
- That type of compensators is not suitable for carrying radial movements, bucklings and torsional forces of the installation.
- These compensators are not to be mounted with pretensioning.

Assembly method

The axial bellow compensators may be mounted on horizontal and vertical pipelines, placed along walls or in transitive and non-transitive heating ducts.

In case of installation in ducts, inspection openings should be provided to allow access to the compensator.

If there is a risk of contamination of the thermally non-insulated compensator elastic bellow, it should be protected with a cover against possible mechanical contamination that may damage it by entering the space between the bellow waves.

If the bellow compensator is thermally insulated, additional cover should be used to protect against entering of the insulation in the spaces between the bellow waves.

It is acceptable to mount not more than one compensator between two adjoining fixed points.

Sliding supports must completely cover the pipes without causing too much resistance to the thermal movements of the pipeline. The maximum slack should be no more than 1 mm.

To obtain the correct stability, compensator must be installed at a distance not greater than $4 \times d$ from the nearest fixed point.

Maximal distance from the compensator to the first sliding point should not exceed $4 \times d$.

The maximum distance between the first and second sliding points must not exceed $14 \times d$.

The distance between successive sliding points should comply with the guidelines on maximum support spacing for Steel/Inox pipes.

Permissible deviation of the pipeline axis on both sides of the compensator must not exceed 2 mm.

Maximum support span [m] – KAN-therm Steel/Inox pipes

External pipe diameter [mm]	15	18	22	28	35	42	54	76,1	88,9	108	139	168
Maximum support span [m]	1,25	1,5	2	2,25	2,75	3	3,5	4,25	4,75	5	5	5

Correct mounting

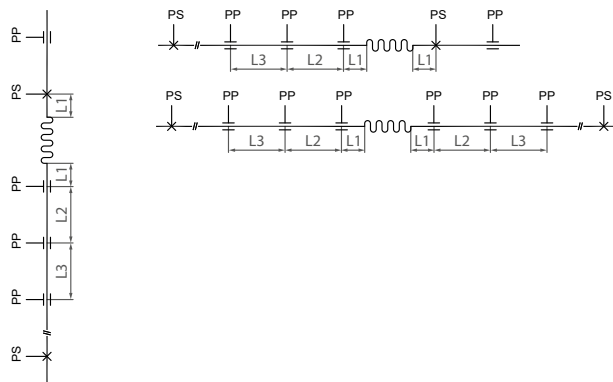

Incorrect mounting

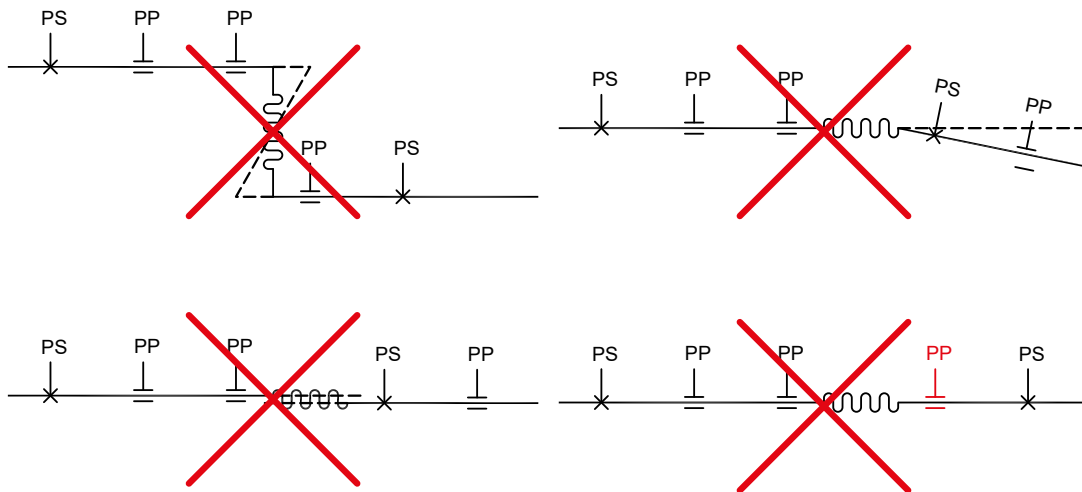

PS	fixed point	L1	max. 4×d
PP	sliding point	L2	max. 14×d
		L3	in accordance with the guidelines on 'maximum support spacing for steel and stainless steel pipes'

Warranty

The warranty for axial bellow compensators is granted for the number of cycles $N_c = 1000$, where each compression and expansion of the bellow (even in the case of incomplete operating range) is considered as one cycle. The number of cycles is specified for temperature 20 ± 5 °C. In the case of other operating temperatures, the number of cycles should be calculated using the temperature reduction coefficient:

$$NC = 1000 \cdot Tf$$

where:

T_{work}	-35 °C	0 °C	20 °C	100 °C	150 °C
Tf (coefficient reductor depends from operating temperature)	0,90	0,95	1,0	0,9	0,85



Warning! Non-axial assembly of compensators results in shortening their service life!

The compensator mounting that is inconsistent with the manufacturer's recommendations leads to warranty loss and shortening their life.

Principles of compensating for installation riser – horizontal elongations

When mounting installation risers/horizontals atop walls and inside installation shafts, you must consider their axis motion caused by temperature changes by carefully arranging fixed points and compensators and compensating for all tensions on branch-offs. This is why every installation subjected to elongations should be treated individually.

The solution you assume depends on the material of risers and branch-offs, the working parameters of the installation, the number of branch-offs on the riser, and the amount of space available (e.g. in the installation shaft). Figures **A**, **B**, **C** present examples of compensation solutions applied in installation risers.

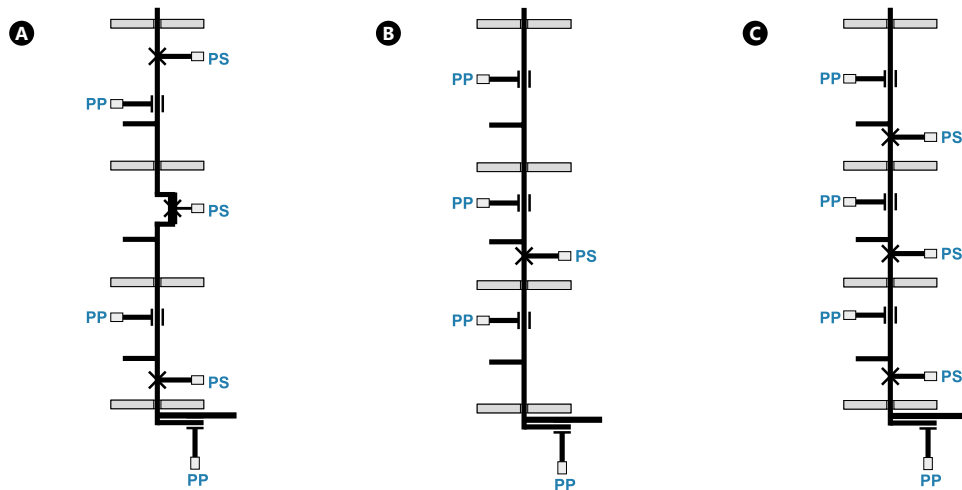

- A.** Example of a riser structure applying an U-shaped compensator (concerns all KAN-therm systems)
- B.** Example of a riser structure applying a fixed point in the middle of the riser (concerns pipes with aluminum layer and KAN-therm: ultraLINE, ultraPRESS, Steel, Inox, Copper)
- C.** Example of a riser structure applying self-compensation ("rigid" structure) (concerns KAN-therm ultraLINE, KAN-therm PP)

In each case, use a compensation arm of sufficient length in the riser connection. In the end of the riser, on the connection to the last container/valve, add a flexible arm of sufficient length.

Each branch-off (e.g. radiator joint, water meter connection) should allow bending (under the influence of vertical motion of the riser) so that tension around the tee is not critical. This may be executed through ensuring correct length of flexible arm (**fig. 1, 2, 3**). It is particularly essential during the assembly of installations in shafts. In the case of a correctly mounted fixed point near a branch-off tee, the requirement of ensuring a flexible arm on this branch-off is not essential.

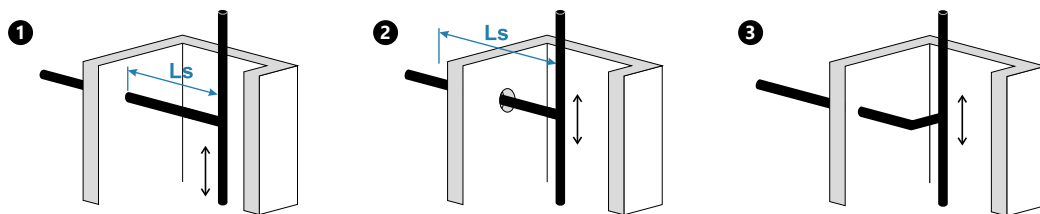

Ensuring a flexible arm on riser branch-offs in installation shafts (examples)

In the case of KAN-therm ultraLINE and PP system pipes, you need not apply any compensation for changes in pipe length by placing fixed point clamps directly above each tee providing branch-off to the pipe. It is a so-called rigid mount (fig. C, pagestr. 164).

By dividing the riser (with fixed points) into considerably small sections (usually the length of the storey, but not longer than 4 m), the length of elongations is restrained, and the remaining tensions are transferred onto the clamps of fixed points. Slight sideways deviations of the pipelines may be limited by dense arrangement of shifting point clamps (denser, if the riser is assembled on plaster in visible places).

Compensation of sub-plaster/sub-flooring installation elongations

In the case of conducting KAN-therm ultraLINE, ultraPRESS and Push system pipelines in layers of concrete (screed) or plaster, the thermal elongation of pipes phenomenon also applies. However, due to the fact that pipes are conducted in casing pipes or in insulation, the tensions caused by pipe elongation are not high, since the pipes have the space to bend in the casing which surrounds them (self-compensation phenomenon). Conducting pipes on small curves also has beneficial impact on thermal elongation.

It is recommended to use 10% excess pipe length compared to the straight line.

This principle should be particularly adhered to when there is a possibility of pipelines shrinking (e.g. cold water installation laid during hot summer) – when arranging a long, straight pipeline without bends or arches. In such case, there is a possibility of the pipe sliding out of the joint, e.g. a tee.

KAN-therm PP polypropylene pipes may be laid directly on floor mortar (if there are no limitations as regards thermal or noise insulation). In this case, the layer of concrete surrounding the pipe does not allow for thermal elongation and the pipe takes on all tensions (they will be lower than the critical value). More about conducting pipes in floor and plaster mortar in chapter Conducting KAN-therm installations in structural partitions.

4 Principles of laying KAN-therm installations

Thanks to a great diversity of solutions and a comprehensive offer of products, KAN-therm allows designing and executing nearly each and every type of internal pressurized installations consisting of horizontals, risers and branch-offs. These elements may be conducted on the surface of plaster or floor slab surfaces (on-plaster mount) or placed in structural partitions (sub-plaster mount – in wall furrows and floor mortars). An indirect method of laying separating pipelines is conducting pipes in special baseboards.

4.1 On-plaster installations – risers and horizontal pipelines

On-plaster mounts on structural partitions are used when conducting installation horizontals in non-inhabited rooms (such as ceiling, garage) and when mounting installations risers e.g. in industrial and non-inhabited facilities or in installation shafts.

This mount is also used in renovations of old installations (e.g. replacement of old heating installations), utilizing KAN-therm PP, Steel, Inox and Copper.

Designing such installations, bear in mind that, apart from technical requirements, also the visual aspect is important. Therefore:

- select the proper type of pipes and joint system,
- carefully develop the system of compensating for thermal elongations,
- adopt a correct method of mounting pipelines, complying with the guidelines,
- select the most suitable (depending on the destination of the installation and its environment) type of thermal insulation.

For on-plaster installations (risers and horizontals), we recommend pipes with aluminum layer (in shafts) from the KAN-therm ultraLINE, KAN-therm ultraPRESS, polypropylene KAN-therm PP pipes and joints or steel pipes from the KAN-therm Steel, Inox as well as KAN-therm Copper system.

4.2 Conducting KAN-therm installations in structural partitions

According to the requirements of modern construction practices, KAN-therm pipelines may be conducted in wall furrows filled with mortar and plaster, as well as various types of floor mortars.

This refers to PERT, PEXC, PPR pipelines, KAN-therm pipes with aluminum layer in separating installation and in tee installations with ultraLINE, and ultraPRESS joints and in welded KAN-therm PP installations.

Examples of conducting pipes in flooring layers:

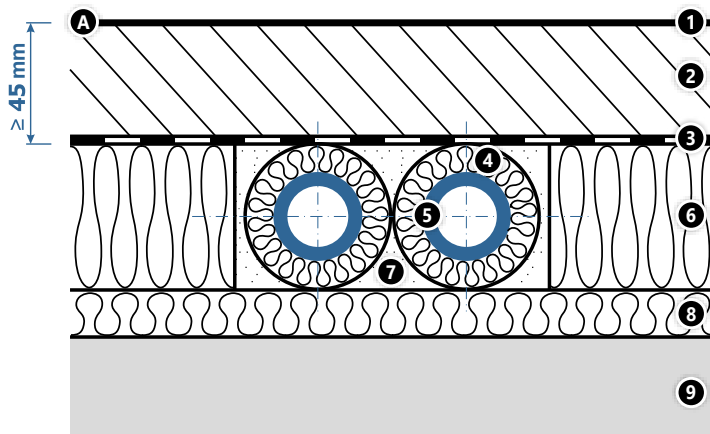

A. On floor slabs above non-heated rooms

1. floor cover
2. concrete mortar
3. foil
4. thermal insulation of pipe
5. KAN-therm system pipe
6. thermal insulation
7. filling, e.g. sand, pellets
8. insulation
9. floor slab

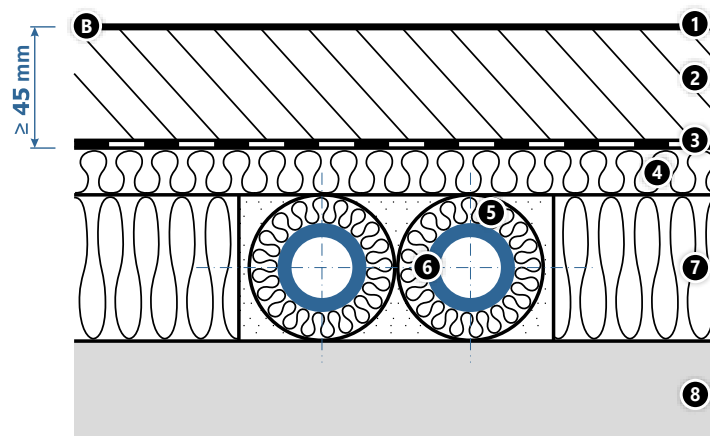

B. On floor slabs above heated rooms

1. floor cover
2. concrete mortar
3. foil
4. acoustic insulation
5. thermal insulation of pipe
6. KAN-therm system pipe
7. thermal insulation
8. floor slab

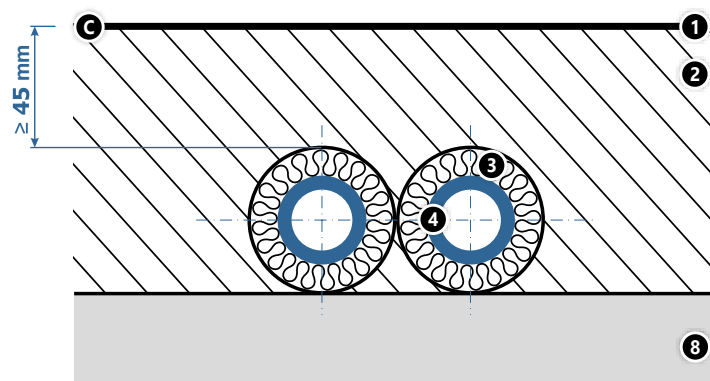

C. Directly on concrete mortar

1. floor cover
2. concrete mortar
3. thermal insulation of pipe
4. KAN-therm system pipe
5. floor slab



Notice

Threaded connections (threaded connectors, threaded adapters, unions) must not be covered with a concrete or plaster. Pipelines in wall grooves should be protected against contact with sharp edges of the groove, preferably by running in protective pipes (conduit) or thermal insulation (if required).

Pipes conducted in floor mortar must be laid in pipe casings or, if thermal protection requirements force so, in thermal insulation (see chapter Thermal insulation of KAN-therm pipes).

Insulation may be used to reduce heat loss, to prevent the floor layer from collecting heat from the pipe (max. 29 °C), and it may partially serve as noise insulation to the pipeline. You may also conduct KAN-therm PP pipes without casings in floor shafts, provided that a required mortar thickness is maintained.

Minimal thickness of concrete layer above the pipe or insulation is 4,5 cm. In the case of smaller thicknesses, it is recommended to make additional screed reinforcement above the pipes. Pipe installations conducted in shafts should not damage the noise insulation. In the case of conducting a pipeline in a casing (pipe-in-pipe) or in thermal insulation, its routing should include small curves in order to prevent the effects of thermal contractions of pipelines.

Pipes have to be mounted to the surface using widely available fasteners e.g. hooks, clamps or specially dedicated tapes. Fastening elements must not cause any damage to the outer surface of pipes, protection pipes or thermal insulation during the operation of the installation. Before the pipelines are covered with plaster or concrete, a pressure test must be carried out and protective coating must be installed. In the course of construction works, covering the installation with screed should be performed under pressure.

Particular care must be taken when using assembly foams in installations containing PPSU fittings. During the application and curing of polyurethane foams, vapours are released which may affect plastic components and, over time, lead to material degradation or the formation of stress microcracks. Direct contact between the foam and the PPSU fitting must be avoided, and prior to application, system components should be adequately secured and protected from the vapours by ensuring proper ventilation and using protective covers.

With sub-plaster installations, we recommend performing an inventory of the installation (e.g. using photographs) before executing any construction works. As a result, you will avoid accidentally damaging the pipes hidden in plaster or mortar.

Laying steel KAN-therm pipes

We do not recommend laying KAN-therm Steel, KAN-therm Inox and KAN-therm Copper installations in plaster or mortar layers, due to the threat of corrosion and the occurrence of strong forces resulting from thermal elongation of pipes.

KAN-therm Steel, KAN-therm Inox and KAN-therm Copper installations may be covered with plaster or screed only if the thermal elongation of pipelines is properly compensated and elements are protected against chemistry of construction components. To enable it, pipes and fittings should be laid in flexible material, e.g. waterproof foam insulation with closed cells. The possibility of contact with moisture, environment containing chlorine or chloride ions or other corrosive environment should also be eliminated by using, for example, full moisture tight insulation.

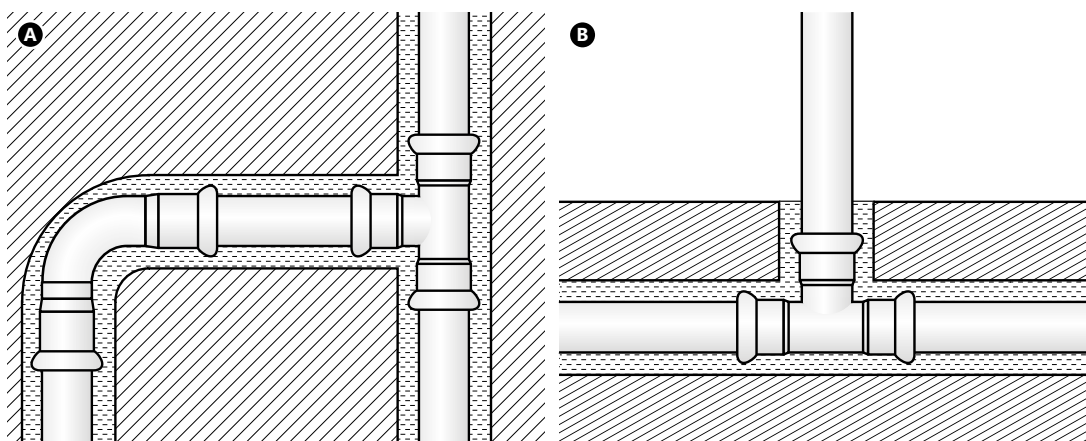

Examples of conducting KAN-therm Steel and KAN-therm Inox

- A. under plaster,
- B. in flooring layers

4.3 Layout of KAN-therm installation

Due to a wide selection of pipe types and joint techniques, KAN-therm will allow executing any type of water supply or heating installation. This concerns both new and renovated buildings.

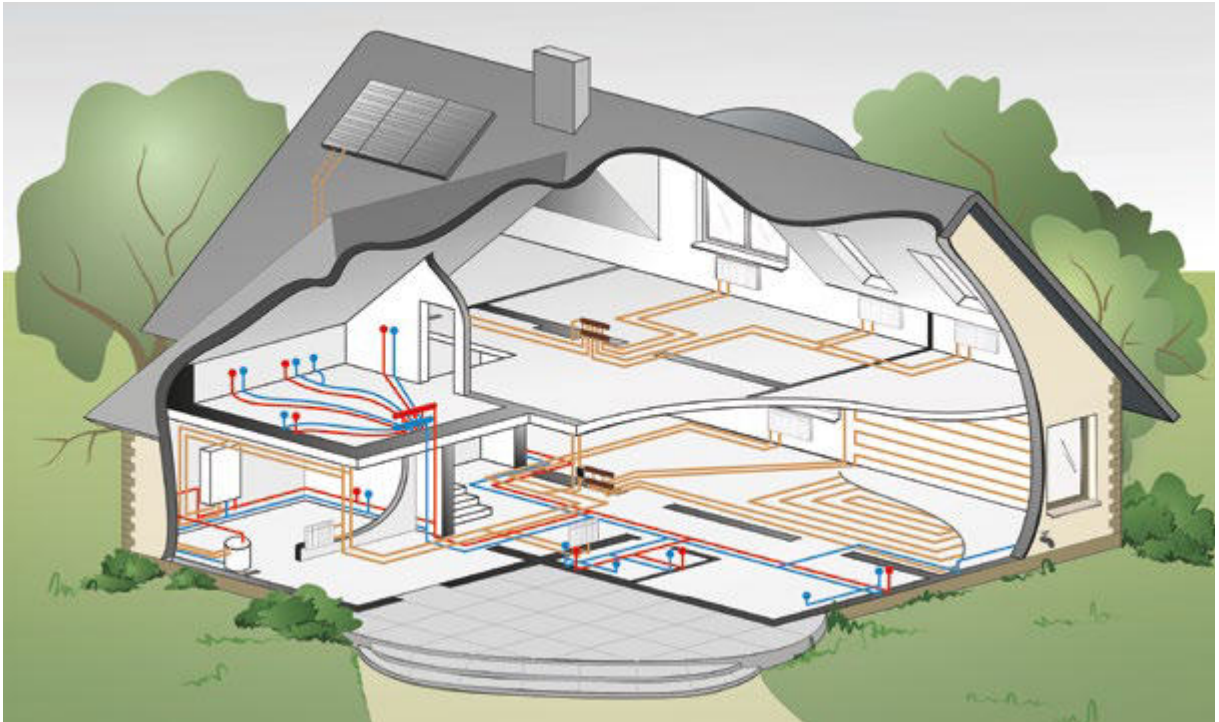

Distribution layout

Receivers (radiators, taps) are fed by separate pipes conducted in floor layers from a KAN-therm manifold. Manifolds are located in on-plaster or sub-plaster KAN-therm boxes or in installation shafts. There are no joints in a floor shaft. There is a possibility of cutting off a medium from each receiver.

Use: radiator heating installations, hot and cold tap water installations.

Pipe types: KAN-therm PERT, PEXC, PERT², pipes with aluminum layer, in coils.

Fixture connections: KAN-therm ultraLINE, KAN-therm ultraPRESS systems, screwed clamps.

Manifold connections: KAN-therm pipes with aluminum layer, KAN-therm PP, Steel, Inox and copper pipes in bars.

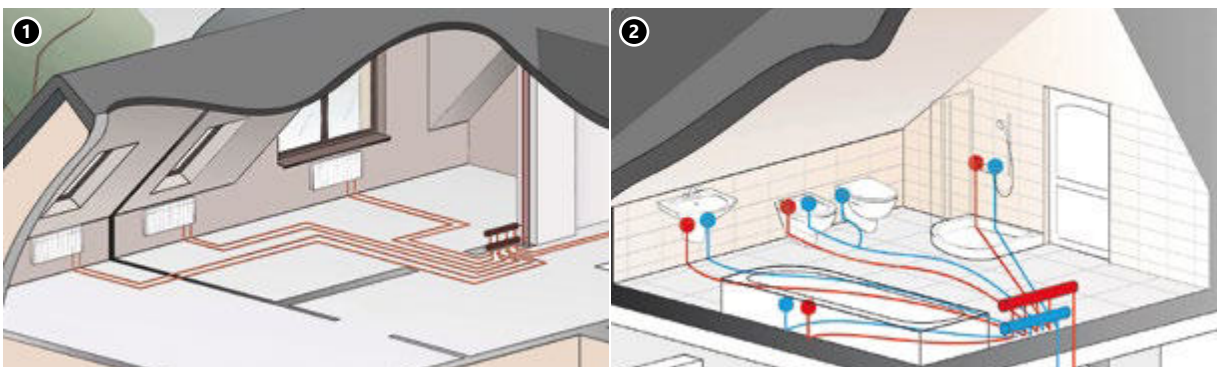

1. Manifold system on a heating installation
2. Manifold system on a water supply installation

Tee system

Receivers are fed from installation risers through a network of pipes conducted in floor layers and in walls. Pipe diameters are gradually decreased towards the receivers. There are pipe joints in floor layers (possibly under plaster). Compared to the manifold system, the number of pipes used to connect devices is lower, however, bigger diameters are used.

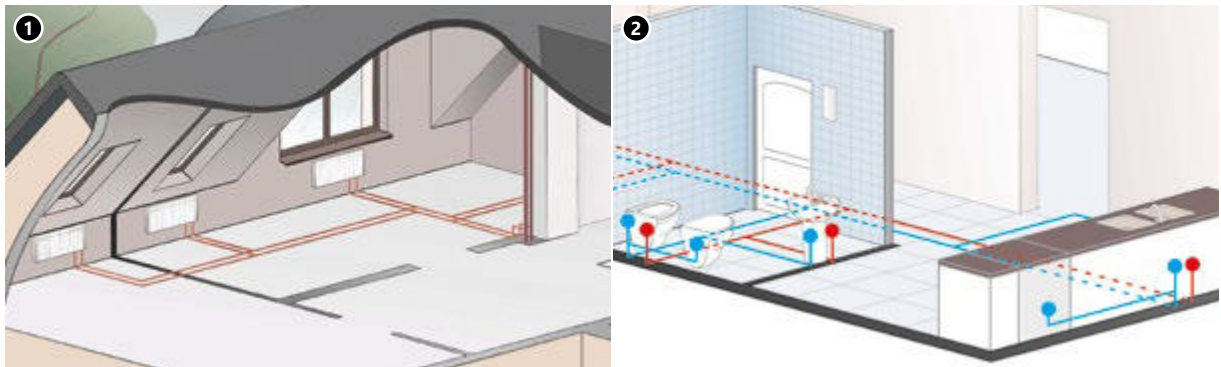

1. Tee system in a heating installation.

2. Tee system in a water supply installation

Use: radiator heating installations, hot and cold tap water installations, new buildings.

Pipe type: KAN-therm PERT, PEXC, PERT², pipes with aluminum layer and KAN-therm PP, in coils and bars.

Fixture connections: KAN-therm ultraLINE, KAN-therm ultraPRESS systems or welded PP systems, threaded joints. Tee connections – only KAN-therm ultraLINE and ultraPRESS or welded PP systems (threaded joints may not be used).

Supply risers (horizontal): KAN-therm pipes with aluminum layer, PP, Steel, Inox and copper pipes in bars.

Manifold – tee system (mixed)

A system based on manifolds, but some manifold pipelines may branch-off. There is a possibility of reducing the number of manifold connections and thus to reduce the total length of pipelines. Tee connections – only KAN-therm ultraLINE and ultraPRESS pressed joints or PP welded joints (threaded joints may not be used).



Manifold – tee system in a heating installation

Loop system

Receivers are fed by a single pipelines conducted in the vicinity of walls, forming one open or closed loop. Pipes may be conducted in floor layers, atop walls or in baseboards. There is a possibility of using them in one-pipe systems. In two-pipe systems, you may also design a simple Tichelmann hydraulic balancing installation. There is a possibility of using it in existing buildings.



Loop system in a two-pipe heating installation

Use: radiator heating installations, hot and cold tap water installations, technological installations, new and renovated buildings.

Pipe type: KAN-therm PERT, PEXC, PERT², PP, pipes with aluminum layer, in coils and bars. KAN-therm Steel, , Inox and copper pipes, in bars (if routed on-wall) pipes (only atop walls).

Fixtures connections: KAN-therm ultraLINE, ultraPRESS or welded PP systems, screwed joints. Tee connections – ultraLINE and ultraPRESS, PP or threaded (only atop walls).

Supply risers: KAN-therm pipes with aluminum layer, PP, Steel, Inox and copper pipes, in bars.

“Vertical” system

A traditional system for feeding receivers, rarely used in new construction projects. Each receiver (or a group of receivers e.g. a water supply junction) is powered by a separate riser. This system is primarily used in renovations of old installations.

Use: radiator heating installations, hot and cold tap water installations, new and renovated buildings.

Pipe type: KAN-therm pipes with aluminum layer, PP, Steel, Inox and copper, in bars.

Fixture connections: KAN-therm ultraLINE, ultraPRESS systems or welded KAN-therm PP systems, threaded joints.

Supply risers: KAN-therm pipes with aluminum layer, PP, Steel, Inox and copper, in bars.



“Vertical” system in a heating installation

5 Connecting installation made of plastic pipes to the heat sources

In order to protect the elements of the piping made of plastics against the direct effects of high temperature of the heat source or other device that may cause excessive heat generation, it is recommended to use a section of metal pipe with a length of not less than 1 m.

All heat sources connected to the installation made of plastics should be protected against exceeding the maximum temperature allowed for the given type and structure of the pipe:

- PEXC, PERT, PERT², PP – 90 °C,
- PERTAL, PERTAL² – 95 °C,
- bluePERT, bluePERTAL – 70 °C.

5.1 Radiator connections

Radiators in modern heating installations may be side-fed (type C) or bottom-fed (type VK). KAN-therm systems offer a wide selection of joints and elements for connecting both types of radiators.

Side-fed radiators – on-plaster installation



Radiator connection (connection pipe and return pipe) in the KAN-therm Steel system

A rare type of radiator connections, primarily used in renovations or replacements of old installations; pipes are connected to radiators with the use of standard system joints with threads.

In the case of KAN-therm ultraLINE pipes with aluminum layer, KAN-therm ultraPRESS pipes or polypropylene KAN-therm PP pipes, connection pipes must be conducted on walls, maintaining the maximal distances between clamps and observing the principles of compensating for elongations. We recommend conducting plastic connection pipes in wall furrows or to hide them behind covers.

In metal KAN-therm Steel, Inox and Copper heating installations, the predominant layout is riser – connection pipes – radiator, in which pipes are connected to radiators using system joints with threads. When modernizing an installation, radiator connections should “trace” the old steel connection pipes.

Side-fed radiators – sub-plaster installation

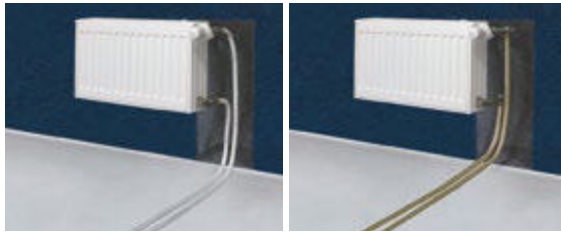

KAN-therm ultraLINE, KAN-therm ultraPRESS and KAN-therm PP systems offer simple ways to connect side-fed radiators, as well as bathroom radiators (tab. Examples of side-fed radiator connections – sub-plaster installations).

Bottom-fed radiators – sub-plaster installation



The most optimal solution for connecting bottom-fed radiators is offered by the KAN-therm ultraLINE; and ultraPRESS systems, basing on special fittings (elbows and tees) with 15 mm copper pipes or 16 mm multilayer pipes (tab. Examples of bottom-fed radiator connections – sub-plaster installations).

5.2 Union connectors for metal pipes

KAN-therm system offer includes three types of union connectors for metal pipes. Union connector for copper pipe G^{3/4}" 1709043005 and G^{1/2}" 1709043003 can work with nickel-plated copper pipes with a diameter of 15 mm. Universal union connector for pipes 1709043010 can work with metal pipes (copper, nickel-plated copper, KAN-therm Steel and Inox pipes with a diameter of 15 mm). The design of the universal union allows its multiple use.

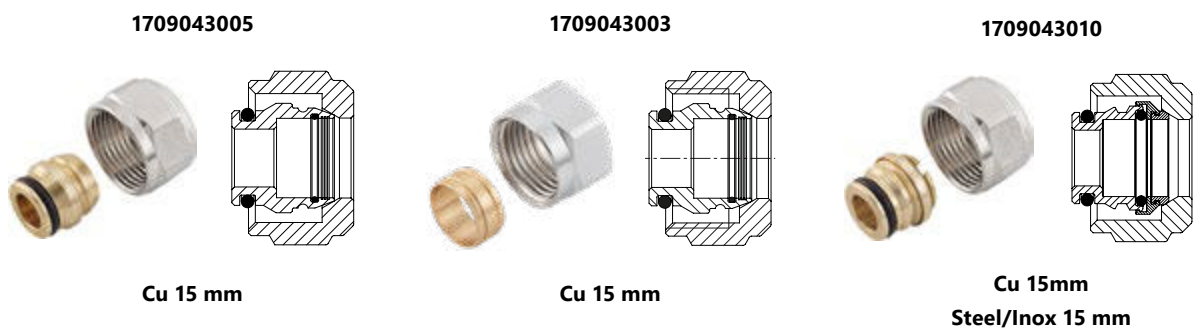

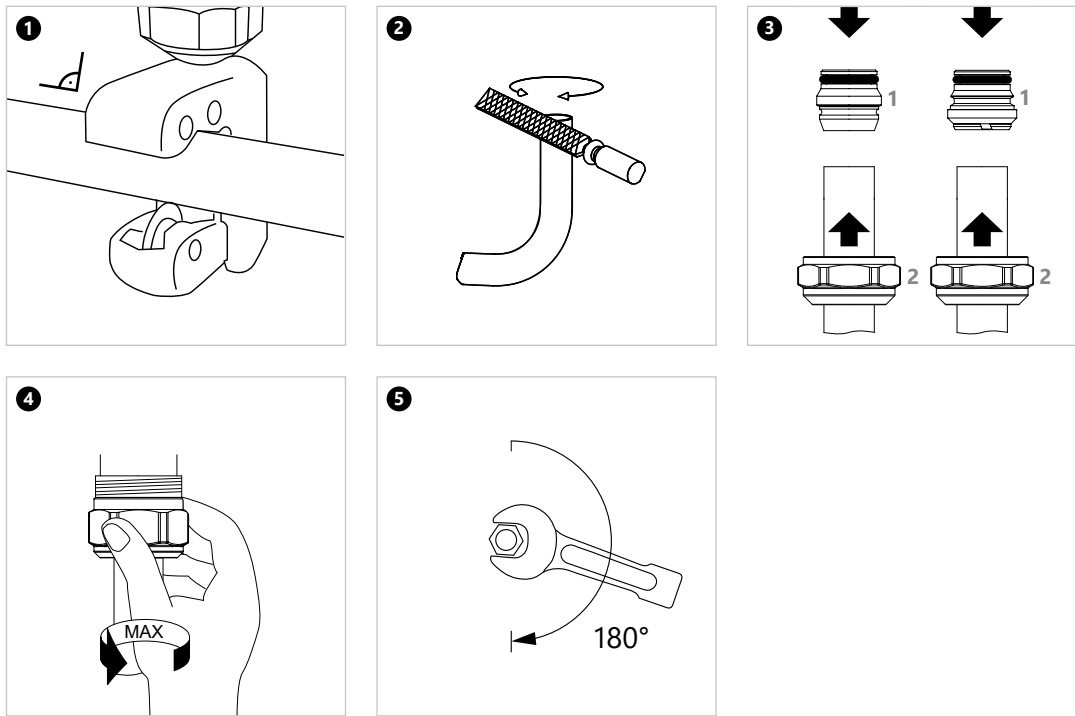

5.3 Water supply device connections

Most KAN-therm systems offer special fittings used for connecting water supply installation devices (tap connections).

Examples of KAN-therm ultraLINE and ultraPRESS systems connections are presented in the table.

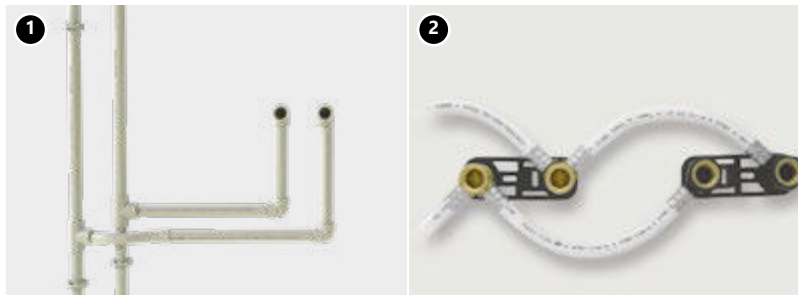









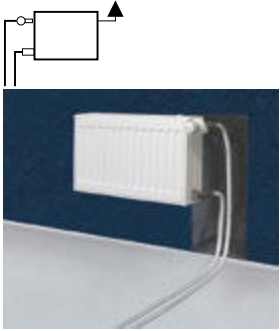



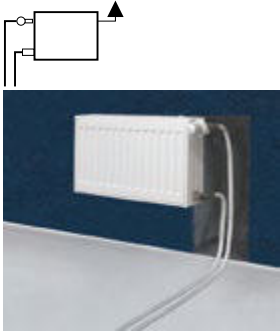

1. KAN-therm PP system tap connection.
2. KAN-therm ultraPRESS system angle tap connection, screwed.

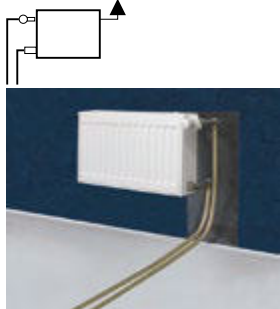
5.4 Requirements for fixing fittings in connection zones.

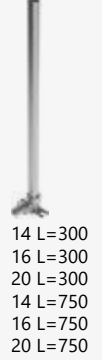
KAN-therm system components must not be subjected to loads or mechanical stress prior to the installation and securing of brackets and fixed points. It is unacceptable to leave fittings unsecured (e.g. wall elbows, radiator connections or tap connections) in situations where the weight of fittings or appliances (e.g. radiators, taps) is transferred to the installation fittings – regardless of the material from which they are made.

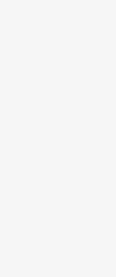
5.5 Radiator connections

Diagram/Description/Photo	KAN-therm connecting element		Supplementary elements
	ultraPRESS	ultraLINE	
SIDE-FED RADIATORS (TYPE C) – WALL CONNECTIONS			
Direct connection			
 <p>wall connection using pressed union adapters</p>	 <p>Ø14 G½" Ø14 G¾" Ø16 G½" Ø14 G¾" Ø20 G¾"</p>	 <p>Ø14 G¾" Ø16 G¾"</p>	 <p>male coupling G½" male reducing coupling G¾" × G½" plastic guide</p>
Direct connection			
 <p>wall connection using press fittings with male thread</p>	 <p>Ø14 Ø16 Ø20</p>	 <p>Ø14 Ø16 Ø20</p>	 <p>plastic guide</p>
Connection utilizing fixed elbows with nickel plated copper pipes			
 <p>single-sided wall connection</p>	 <p>16 × 2 L=210 16 × 2 L=300 16 × 2 L=750</p>	 <p>14 L=300 16 L=300 20 L=300 14 L=750 16 L=750 20 L=750</p>	 <p>plastic guide copper pipe union Ø15 G¾" copper pipe union Ø15 G½" fitting G½" × G½"</p>
 <p>cross wall connection</p>	 <p>14 L=300 16 L=300</p>	 <p>14 L=300 16 L=300</p>	 <p>Ø14 Ø16 Ø20</p>

Diagram/Description/Photo	KAN-therm connecting element		Supplementary elements
	ultraPRESS	ultraLINE	

BOTTOM-FED RADIATORS (TYPE VK) – FLOOR CONNECTIONS

Direct connection using pressed union adapters

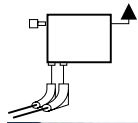

without connection valves



Ø14 G $\frac{1}{2}$ "
 Ø14 G $\frac{3}{4}$ "
 Ø16 G $\frac{1}{2}$ "
 Ø16 G $\frac{3}{4}$ "
 Ø20 G $\frac{3}{4}$ "



Ø14 G $\frac{3}{4}$ "
 Ø16 G $\frac{3}{4}$ "
 Ø20 G $\frac{3}{4}$ "



plastic elbow



plastic pipe end cap

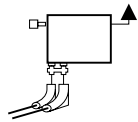

with simple connection valves
 (single or integrated)



Ø16 G $\frac{1}{2}$ "
 Ø16 G $\frac{3}{4}$ "
 Ø20 G $\frac{3}{4}$ "



plastic elbow





plastic pipe end cap

Diagram/Description/Photo	KAN-therm connecting element		Supplementary elements
	ultraPRESS	ultraLINE	

BOTTOM-FED RADIATORS (TYPE VK) – FLOOR CONNECTIONS

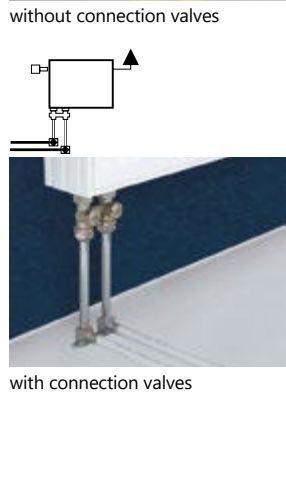
Connection with simple elbows (single or double) and Cu 15 mm pipes

 <p>without connection valves</p>	 <p> $\text{Ø}16 \times 2 \text{ L}=200$ $\text{Ø}16 \times 2 \text{ L}=300$ </p> <p> $\text{Ø}14 \times 2 \text{ L}=300$ $\text{Ø}16 \times 2 \text{ L}=300$ $\text{Ø}20 \times 2 \text{ L}=300$ </p>	 <p> $\text{Ø}15 \text{ G}3/4$" copper pipe union $\text{G}1/2$" \times $\text{G}1/2$" joint body </p>
 <p>with connection valves</p>	 <p> $\text{Ø}16 \times 2,5 \text{ L}=210$ $\text{Ø}16 \times 2,5 \text{ L}=300$ $\text{Ø}16 \times 2,5 \text{ L}=750$ </p> <p> $\text{Ø}14 \times 2 \text{ L}=300$ $\text{Ø}16 \times 2 \text{ L}=300$ $\text{Ø}20 \times 2 \text{ L}=300$ $\text{Ø}14 \times 2 \text{ L}=750$ $\text{Ø}16 \times 2 \text{ L}=750$ $\text{Ø}20 \times 2 \text{ L}=750$ </p> <p> $\text{Ø}14$ $\text{Ø}16$ $\text{Ø}20$ </p>	 <p> $\text{Ø}15 \text{ G}1/2$" copper pipe union $\text{Ø}15 \text{ G}1/2$" copper pipe union </p>

Diagram/Description/Photo	KAN-therm connecting element		Supplementary elements
	ultraPRESS	ultraLINE	

BOTTOM-FED RADIATORS (TYPE VK) – FLOOR CONNECTIONS

Connections with Ø15 mm copper pipe

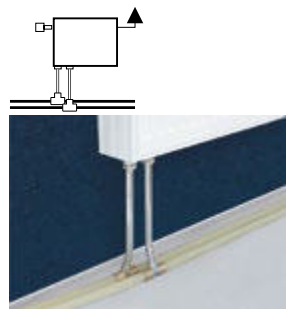

without connection valves

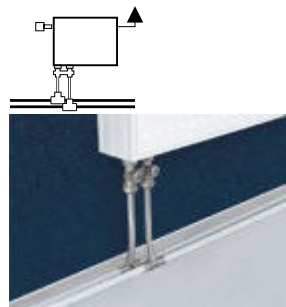

with connection valves

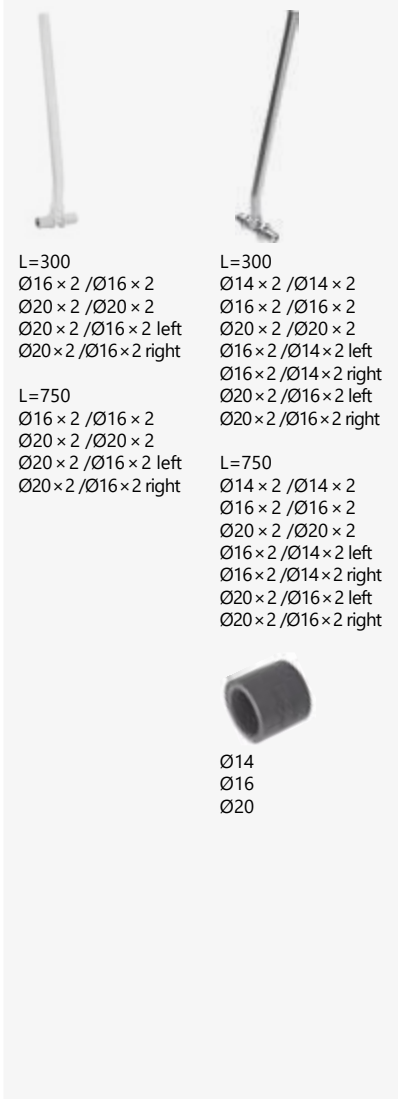

L=300
 Ø16 × 2 / Ø16 × 2
 Ø20 × 2 / Ø20 × 2
 Ø20 × 2 / Ø16 × 2 left
 Ø20 × 2 / Ø16 × 2 right

L=750
 Ø16 × 2 / Ø16 × 2
 Ø20 × 2 / Ø20 × 2
 Ø20 × 2 / Ø16 × 2 left
 Ø20 × 2 / Ø16 × 2 right

L=300
 Ø14 × 2 / Ø14 × 2
 Ø16 × 2 / Ø16 × 2
 Ø20 × 2 / Ø20 × 2
 Ø16 × 2 / Ø14 × 2 left
 Ø16 × 2 / Ø14 × 2 right
 Ø20 × 2 / Ø16 × 2 left
 Ø20 × 2 / Ø16 × 2 right

L=750
 Ø14 × 2 / Ø14 × 2
 Ø16 × 2 / Ø16 × 2
 Ø20 × 2 / Ø20 × 2
 Ø16 × 2 / Ø14 × 2 left
 Ø16 × 2 / Ø14 × 2 right
 Ø20 × 2 / Ø16 × 2 left
 Ø20 × 2 / Ø16 × 2 right

Ø14
 Ø16
 Ø20



Ø15 G $\frac{1}{2}$ " copper pipe ring



G $\frac{1}{2}$ " × G $\frac{1}{2}$ " fitting



Ø15 G $\frac{1}{2}$ " copper pipe union



Ø15 G $\frac{3}{4}$ " copper pipe union



End cap for Cu Ø15 pipe

Diagram/Description/Photo	KAN-therm connecting element		Supplementary elements
	ultraPRESS	ultraLINE	

BOTTOM-FED RADIATORS (TYPE VK) – WALL CONNECTIONS

Direct connection

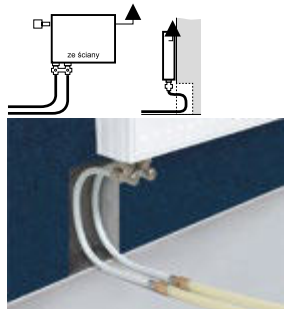

to angle block



Connection with single or double fixed elbow with copper pipes

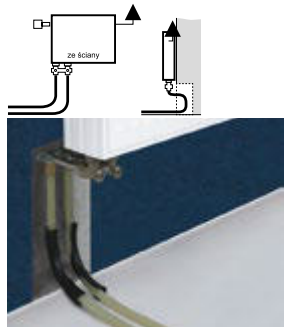

(with a Cu 15 mm pipe) for angle valve block



5.6 Tap connections

Diagram/Description/Photo	KAN-therm connecting element		Supplementary elements
	ultraPRESS	ultraLINE	
SYSTEM CONNECTIONS - FLUSH INSTALLATIONS (IN FURROWS), SURFACE INSTALLATIONS AND IN DRY SCREED			
Single connection			
	<p>Not suitable for dry screed $\text{Ø}16 \times 2 \text{ G}1/2''$ $\text{Ø}20 \times 2 \text{ G}1/2''$</p> <p>$\text{Ø}14$ $\text{Ø}16$ $\text{Ø}20$</p>	<p>mounting plates</p> <p>double (L=50, 80, 100, 150 mm) double L=50</p>	
Double connection (tap)			
	<p>$\text{Ø}16 \times 2 \text{ G}1/2''$ $\text{Ø}20 \times 2 \text{ G}1/2''$</p>	<p>Not suitable for dry screed single double (L=150 mm) double (L=80 mm) double (L=50 mm)</p>	
Joint with outlet			
	<p>$\text{Ø}14 \times 2 \text{ G}1/2''$</p>	<p>mounting plates</p> <p>double (L=50, 80, 100, 150 mm) double L=50</p> <p>Not suitable for dry screed single double (L=150 mm) double (L=80 mm) double (L=50 mm)</p>	

Diagram/Description/Photo	KAN-therm connecting element	Supplementary elements
	ultraPRESS	

SCREWED CONNECTIONS (UNION ADAPTERS) - ON-PLASTER INSTALLATIONS

Single connection

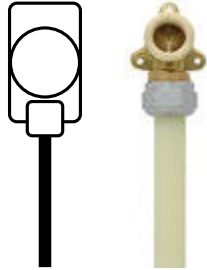

G $\frac{1}{2}$ "
G $\frac{3}{4}$ "
mounting plates



double
(L=50, 80, 100, 150 mm)
double L=50

Double connection (tap)

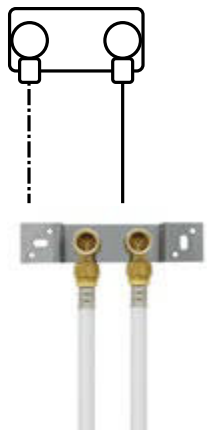

double
(L=50, 80, 100, 150 mm)
double L=50



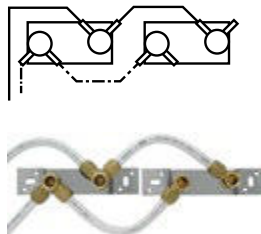



Joint with outlet

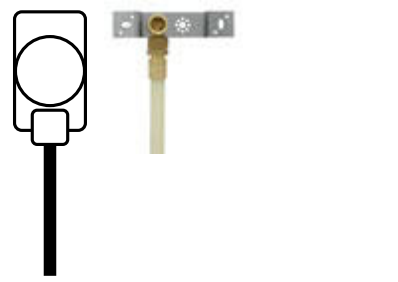

G $\frac{1}{2}$ "
G $\frac{3}{4}$ "
mounting plates

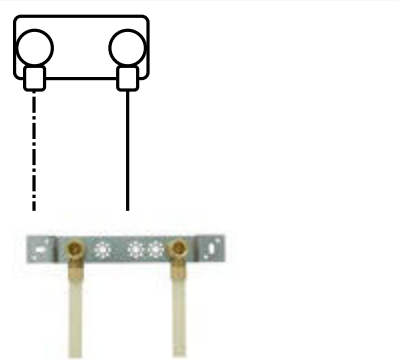

double
(L=50, 80, 100, 150 mm)
double L=50

Diagram/Description/Photo	KAN-therm connecting element	Supplementary elements
	ultraPRESS	
SCREWED JOINTS WITH FITTINGS WITH FEMALE THREADS – ON-PLASTER INSTALLATIONS		
<p>Single connection</p> 	 <p>Ø16 × 2 G½" Ø20 × 2 G½"</p>  <p>Ø16 × 2 G½"</p>	<p>mounting plates</p>  <p>double (L=50, 80, 100, 150 mm) double L=50</p>
<p>Double connection (tap)</p> 	 <p>G ½"</p>  <p>G ½"</p>	

6 Compressed air installations in KAN-therm system

Apart from being used in standard heating and potable water installations, KAN-therm system components can be successfully used to build quite specific compressed air installations. The compressed air distribution system is a collection of pipes, fittings (elbows, tees, reducers) and couplings used for its transport from the place of production to the points of consumption (machines, tools). Each of the above mentioned elements should be properly selected according to the user's needs and the quality, quantity and pressure of the transmitted air.

The piping system that transports compressed air to the collection points is one of the most important parts of the entire installation. This includes both main transmission pipelines and machine connections. Poorly sized and assembled elements (e.g. too small diameters of transmission or connection pipelines, too "complicated" installation) will generate large pressure drops, and thus higher operating costs. This will be due to the higher energy consumption of the compressors and the need to operate at high pressure. Lowering the operating pressure of the compressor by 1 bar, reduces energy consumption by more than 7%.

The scope of application of KAN-therm system in compressed air installations

System name	pipe	sealing	Solid particulate class **										Moisture content class **										Oil content class **				Remarks		
			0	1	2	3	4	5	6	7	X	0	1	2	3	4	5	6	7	8	9	X	0	1	2	3		4	X
KAN-therm Inox / Inox XPress Sprinkler	1.4404	EPDM	-	*	*	*	+	+	+	+	+	+	+	+	+	+	+	+	+	+	+	+	+	+	+	+	+	-	P _{max} = 16 bar 12-54 mm; 10 bar >54 mm
		FPM	-	*	*	*	+	+	+	+	+	+	+	+	+	+	+	+	+	+	+	+	+	+	+	+	+	+	
KAN-therm Inox XPress Sprinkler	1.4401	EPDM	-	*	*	*	+	+	+	+	+	+	+	+	+	+	+	+	+	+	+	+	+	+	+	+	+	-	P _{max} = 16 bar 12-54 mm; 10 bar >54 mm
		FPM	-	*	*	*	+	+	+	+	+	+	+	+	+	+	+	+	+	+	+	+	+	+	+	+	+	+	
KAN-therm Inox XPress Sprinkler	1.4521	EPDM	-	*	*	*	+	+	+	+	+	+	+	+	+	+	+	+	+	+	+	+	+	+	+	+	+	-	P _{max} = 16 bar 12-54 mm; 10 bar >54 mm
		FPM	-	*	*	*	+	+	+	+	+	+	+	+	+	+	+	+	+	+	+	+	+	+	+	+	+	+	
KAN-therm Steel / Steel XPress Sprinkler	1.0034 (Galvanized external)	EPDM	-	-	-	-	+	+	+	+	+	+	+	+	+	+	+	+	+	+	+	+	+	+	+	+	+	-	P _{max} = 16 bar 12-54 mm; 10 bar >54 mm
		FPM	-	-	-	-	+	+	+	+	+	+	+	+	+	+	+	+	+	+	+	+	+	+	+	+	+	+	
		EPDM	-	-	-	-	+	+	+	+	+	+	+	+	+	+	+	+	+	+	+	+	+	+	+	+	+	+	
		FPM	-	-	-	-	+	+	+	+	+	+	+	+	+	+	+	+	+	+	+	+	+	+	+	+	+	+	
KAN-therm Copper	acc. EN 1057	EPDM	-	-	-	-	+	+	+	+	+	+	+	+	+	+	+	+	+	+	+	+	+	+	+	+	+	-	P _{max} = 10 bar
		FPM	-	-	-	-	+	+	+	+	+	+	+	+	+	+	+	+	+	+	+	+	+	+	+	+	+	+	
KAN-therm ultraLINE	PEXC, PERT2, PERTAL2,	-	+	+	+	+	+	+	+	+	+	+	+	+	+	+	+	+	+	+	+	+	+	+	+	+	+	-	P _{max} = 10
KAN-therm ultraPRESS	PERTAL	EPDM	+	+	+	+	+	+	+	+	+	+	+	+	+	+	+	+	+	+	+	+	+	+	+	+	+	-	P _{max} = 10
KAN-therm PP PN16	PPR, stab/GLASS,	-	+	+	+	+	+	+	+	+	+	+	+	+	+	+	+	+	+	+	+	+	+	+	+	+	+	-	P _{max} = 16 bar at 20 °C or 10 bar at 40 °C
KAN-therm PP PN20	PPR, stab/GLASS	-	+	+	+	+	+	+	+	+	+	+	+	+	+	+	+	+	+	+	+	+	+	+	+	+	+	-	P _{max} = 20 bar at 20 °C or 10 bar at 60 °C

+ Possible area off application

- Non-applicability

* Should be consulted individually with KAN

**Purity class acc. to ISO 8573-1:2010-04

In the case of EPDM, contact is permitted only with synthetic oil (maximum content in accordance with Class 4 of ISO 8573-1:2010-04). Mineral oils are not permitted.

7 Rinsing, tightness tests and disinfection of KAN-therm installations

After completing, the KAN-therm installation should be rinsed and pressure tested. It should be done before pouring screed on the pipes, and covering the furrows and channels.

Perform a leak test with water. If the conditions do not allow conducting a water test (e.g. low temperatures), you may also conduct a compressed air test.



Notice

If there is a need to empty a KAN-therm Steel installation after the test, we recommend conducting the test using compressed air.

Before starting the test:

- disconnect fixtures and devices which could distort the results of the test or which could get damaged during the test (e.g. retention reservoirs, safety valves),
- thoroughly rinse the installation, rinsing the installation should be performed with tap water or with the medium to be ultimately transported through the installation. During the flushing process, it should be ensured that the full capacity of the installation is replaced at least once,
- fill the installation with clear water and de-air it,
- stabilize water temperature in comparison to air temperature.

Use a shield manometer with a scope exceeding the working pressure by 50% and minimum graduation of 0,1 bar. The manometer should be mounted on the lowest point of the installation. Ambient temperature of the installation should not change.

After finishing the pressure test, you must write a report specifying the test pressure, the course of the test according to the procedure, pressure drop values and a statement whether the test ended with a positive (or negative) result. The report can be written as a form.

After a positive result of the pressure test, heating installations and hot tap water installations must be tested with the use of hot water (hot pressure test).

The test pressure values (depending on the type of installation) and the test conditions for all KAN-therm systems are set out below

7.1 Water pressure test

Initial assumptions – test pressure values P_t

1. Heating systems and chilled water systems

For heating systems and chilled water systems, the test pressure P_p shall be assumed as:

$$P_t = P_{op} + 2 \text{ bar}$$

however not less than 4 bar

This means that:

- if the operating pressure of the system is e.g. 1.5 bar → the water pressure test must be carried out at min. 4 bar,
- if the operating pressure of the system is e.g. 4 bar → the water pressure test should be carried out at 6 bar.

2. Water supply systems (potable water)

For water supply systems, the test pressure P_t shall be assumed as:

$$P_t = P_d \times 1,1$$

Example:

- if the maximum allowable operating pressure is 10 bar →

$$P_t = 1,1 \times 10 \text{ bar} = 11 \text{ bar.}$$

P_t - ciśnienie próbne

P_{op} - ciśnienie robocze

P_d - ciśnienie projektowe systemu

Methodology for carrying out water tightness test

Step 1 – Preliminary water test (reduced pressure)

- Test pressure: 1.0 to 4.0 bar
- Test duration: Time allowing visual inspection of all system connections
- Acceptance criteria: No sweating and no leaks

Step 2 – Intermediate water test

- Applies only to: ultraLINE, ultraPRESS, PP, underfloor heating (for metal systems proceed directly to step 3)
- Test pressure: P_t (test pressure) – see initial assumptions
- Test duration:
 - 30 minutes (during this time maintain the test pressure, equalize if necessary)
 - After 30 minutes, reduce the pressure to $0.5 \times P_t$ (continuation – step 3)
- Acceptance criteria: No sweating and no leaks

Step 3 – Main water test

- Test pressure:
 - P_t - Steel, Inox, Inox 304, Copper
 - $P_t \times 0,5$ (after reduction according to step 2) – ultraLINE, ultraPRESS, PP, surface heating
- Test duration
 - 30 minutes – ultraLINE, ultraPRESS, PP, surface heating
 - 10 minutes – Steel, Inox, Inox 304, Copper systems
- Permissible pressure drop: none (0.0 bar)
- Acceptance criteria: No sweating, no leaks and no pressure drop

7.2 Tightness tests with compressed air

Step 1 – Compressed air tightness test (low pressure)

- Test pressure: 110 mbar (0.11 bar)
- Test duration:
 - 30 minutes – for systems with test medium volume up to 100 l
 - for each additional started volume of 100 l of test medium, extend the test time by 10 minutes
- Acceptance criteria: No pressure drop

Step 2 – Compressed air tightness test (increased pressure)

- Test pressure:
 - ≤ DN50 – max. 3,0 bar*
 - > DN50 – max. 1,5 bar
- Test duration: 10 minutes
- Acceptance criteria: No pressure drop

* It is permitted to use compressed air test pressure exceeding 3 bar, provided that a positive result of the tightness test and the load tightness test at increased pressure is obtained, and that appropriate personnel safety conditions are ensured.

According to the guidelines of the Technical Conditions for Execution and Commissioning of Heating and Water Supply Installations, in justified cases (e.g. danger of freezing or excessive corrosion), it is allowed to carry out a pressure test using compressed air only.

The air used for the test cannot contain any oils. In case of KAN-therm Steel system, the compressed air must be free of moisture. Ambient temperature of the installation should not change (max ± 3 °C). Any leaks detected can be located using acoustic methods or, only after consulting KAN's Technical Support Department, using a foaming agent. The pressure gauge must allow for accurate pressure verification at 110 mbar. Test results are considered positive when no installation leaks are detected and no pressure drops occur on the manometer.



Caution:

Some of the foaming agents used to locate leaks during leak testing with compressed air may adversely affect the material of pipes and fittings. Before using them, consult with KAN Technical Support Department.

8 KAN-therm system installation disinfection

KAN-therm systems (except from KAN-therm Steel) are suitable for the construction of drinking water installations and have the necessary hygiene certificates. The selection of construction materials does not affect the multiplication of pathogenic organisms or deterioration of the properties of drinking water.

However, due to errors in the construction process or during the use of the installation, as well as periods of downtime or contamination of tap water, it may be necessary to disinfect the installation. It should be remembered that disinfection removes only the effects of contamination - before it is carried out, the causes of contamination of the medium must be removed.

Thermal disinfection

Thermal disinfection is performed with clean water at an increased temperature. In order to effectively carry out thermal disinfection, it must be ensured that at all points of tap water consumption there is an outflow of water at a temperature of 70 °C in not less than 3 minutes. Care must be taken to ensure that the permissible operating parameters (maximum permissible temperature as a function of operating pressure) of the relevant installation system are not exceeded at any point in the installation. At the same time, it is necessary to ensure the safety of all users of the given installation (minimize the risk of burns).

Please note that the operation of the installation at elevated temperatures shortens the service life of the construction materials used, therefore it should be performed only periodically.

Chemical disinfection

Chemical disinfection can be performed in drinking water installations made of all KAN-therm systems. Chemical disinfection is carried out at ambient temperature (not higher than 25 °C) with the use of reagent doses and exposure time specified by the compound manufacturer. Before using a chemical agent, it is necessary to obtain a written confirmation that it does not adversely affect the components of the installation. During chemical disinfection, water should not be drawn from the system for drinking purposes.

Examples of chemical disinfection agents approved for use with KAN-therm systems:

Name of the substance	Max. permissible concentration	Time of reaction
Hydrogen peroxide H_2O_2	150 mg/l of active ingredient	
Sodium hypochlorite $NaOCl$	50 mg/l of active ingredient	max. 12 h
Calcium hypochlorite $Ca(OCl)_2$	50 mg/l of active ingredient	
Chlorine dioxide ClO_2	6 mg/l of active ingredient	

i The above-mentioned concentrations and reaction times of the substances must not be exceeded at any point in the installation.

i Use personal protective equipment when dosing chemicals. It is unacceptable to use a combination of thermal disinfection and chemical disinfection.



**KAN-therm
MULTISYSTEM**

> 35 | years of experience
on the installation
market

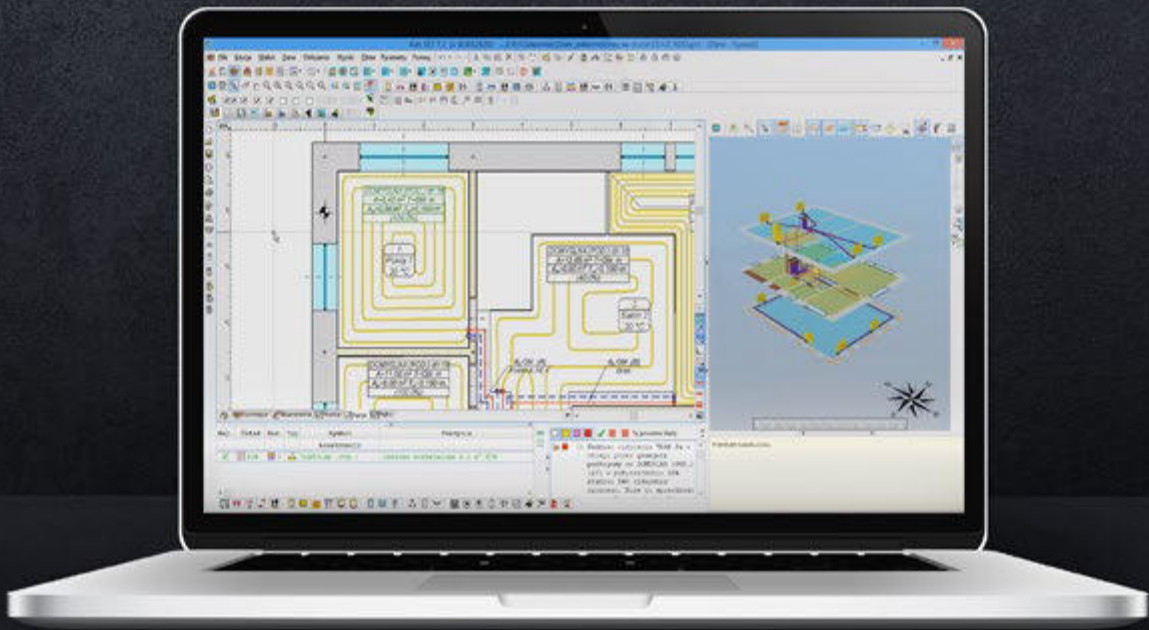

KAN-therm

Designing an installation

Install the **future**

Designing an installation

1	KAN-therm software supporting the design process	189
2	Hydraulic dimensioning of KAN-therm installations	190
2.1	Dimensioning water supply installations	190
2.2	Dimensioning central heating installations	192
3	Thermal insulation of KAN-therm installations	193

Designing an installation

1 KAN-therm software supporting the design process

The principles of designing KAN-therm water supply and heating installations are similar to all commonly used installations basing on applicable standards and guidelines for dimensioning. KAN recommends using company programs supporting the design process, significantly improving the calculation process. These software contains catalogs of all KAN-therm systems currently in offer. This way, designers get access to universal tools allowing them to set any dimensions for any available installation technique.

The complete KAN software offer includes:

1. **KAN OZC program for supporting the calculation of the design heat loads of rooms, determining the seasonal demand for heating and cooling energy in buildings and the preparation of Energy Certificates for buildings and their parts. The software also perform moisture analysis of building partitions.**
2. **The KAN SET software is a comprehensive design support tool that combines in one project the calculation of cold and hot water installations with circulation as well as central heating and cooling installations. It consists of three modules:**
 - Central heating system module, including radiant / underfloor heating.
 - Cold and hot water installation module with circulation.
 - Central cooling system module.
3. **KAN SET for REVIT overlay - plug-in for Autodesk® Revit®. It allows for an import of a project from KAN SET Pro to the Autodesk® Revit® environment. The plugin enables easy and convenient design of installations using KAN-therm products.**

More information available at en.kan-therm.com

2 Hydraulic dimensioning of KAN-therm installations

Below, we present the basic formulas and interrelations as well as recommendations for traditional dimensioning of pipe diameters, calculating heat loss parameters and providing hydraulic balance to water supply and heating installations. Appendix to Guide "Tables for hydraulic calculations of KAN-therm water supply and heating installations" is an integral part of this chapter.

2.1 Dimensioning water supply installations

The course of designing KAN-therm installations is based on principles defined by specified standards. In contrast to traditional steel installations, thanks to the reduced roughness of the walls of plastic KAN-therm pipes and KAN-therm Inox pipes, the level of linear resistance is strongly reduced in general installation resistance rates. Hence, there is no need to increase pipe diameters to account for probable pipe scaling. The absolute roughness k coefficients of pipes should be taken in accordance with the values given in the previous parts of this study.

Calculation flow q of water in the installation is calculated according to formulas specified in the standard. For housing buildings, this calculation is defined basing on normative outflows from intakes specified in table 1 of the Appendix. After adding all normative outflows, we can calculate flow q or select it from the values specified in table 2 of the Appendix.

Estimated diameters of KAN-therm connection pipes to intake points

Nominal diameter of intake point d_n [mm]	Estimated diameters of connections to intake points			
	KAN-therm ultraLINE pipes	KAN-therm ultraPRESS pipes with aluminum layer	PPR KAN-therm PP pipes	Stainless steel KAN-therm Inox pipes and copper pipes
15	14×2; 16×2,2	14×2; 16×2	16×2,7; 20×1,9; 20×2,8; 20×3,4	15×1,0
20	20×2,8; 25×2,5	20×2	20×1,9; 25×3,5; 25×4,2	18×1,0
25	32×3	25×2,5; 26×3	25×2,3; 32×4,4; 32×5,4	22×1,2

Having the q value of permissible speeds on a given section of the installation, we can preliminarily mark the diameter of the pipe. The following step is calculating pressure loss Δp which is a sum of linear resistance $\Delta p_L = R \times L$ and local resistance Z on pipeline sections.

Linear pressure loss is calculated for particular pipeline sections basing on the generally applied formula:

$$\Delta p_L = R \times L = \lambda \times \frac{L}{d} \times \frac{v^2}{2} \times \rho$$

where:

R [Pa]	linear pressure loss unit
λ	hydraulic linear resistance coefficient taking into account the pipe roughness coefficient
L [m]	length of a pipe of a given diameter
d [m]	internal diameter of the pipe
v [m/s]	average flow speed inside the pipe
ρ [kg/m ³]	water density

In order to specify linear loss of pipeline directly (for various flows, pipe diameters and water temperatures 10° and 60°), use the "Tables for the Designer and Contractor Guidebook". Local loss Z is calculated basing on the following formula:

$$Z = \zeta \times \frac{v^2 \times \rho}{2}$$

where:

Z [Pa]	local loss (resistance) values
ζ	local resistance coefficient

Values of local resistance coefficients in KAN-therm systems are provided in tables included in the "Appendix". ζ values are also provided for KAN-therm Inox fittings, together with replacement lengths corresponding to the local resistance values of these elements.

ζ values for other devices are specified by the manufacturers.

The table below shows the normative pipeline flow rates for KAN-therm ultraLINE, Push, ultraPRESS and PP systems. (In practice, slightly higher values entered in brackets may be used):

Estimated flow speeds in KAN-therm water supply pipelines	[m/s]
in household water supply connections	v = 1,0 – 1,5 (2,0)
in manifold pipes	v = 1,0 – 1,5 (2,0)
in risers	v = 1,0 – 2,0 (2,5)
in sections to riser to devices	v = 1,5 – 2,0 (3,0)

A useful criterion for selecting pipe diameters may be the maximal permissible flow speed, depending on the duration of peak flow and the resistance coefficient of the fixtures mounted on the section of installation in calculation (acc. to DIN 1988).

Maximal flow speed in water supply installations

Pipe type	Maximal flow speed [m/s] for the duration of peak flow	
	≤ 15 min.	> 15 min.
Connections	2	2
Sections of distribution pipes with fixtures with low resistance coeff. (<2,5), e.g. ball valves	5	2
Sections of distribution pipes with fixtures with high resistance coeff. (>2,5), e.g. simple globe valves	2,5	2

Adopting higher speeds than in traditional metal pipe installations is possible thanks to considerably lower vulnerability of plastic KAN-therm pipes to vibrations and noise. We recommend the use of fixtures (valves) with low flow resistance rates.

In order to calculate the volume of hot and circulation water in pipes, assume the water capacity rates of KAN-therm pipes specified in tables "Dimension parameters of pipes" in chapters describing each KAN-therm system.

2.2 Dimensioning central heating installations

Hydraulic dimensioning of heating installations is based on selecting pipeline diameters as well as regulator diameters to ensure that a correct amount of medium reaches each heating device, and to ensure that the entire installation is hydraulically balanced.

KAN-therm pipes for central heating installations should be dimensioned in accordance with applicable standards.

A useful criterion for selecting pipe diameters in central heating installations may be the water flow speed coefficient, which would correspond to the linear economic pressure drops c.a. 150 – 200 Pa/m. Consider the principle that the water flow speed should not exceed the threshold of noise-free operation of the installation (with fixtures). An additional criterion may be the recommended speeds in particular installation pipes:

Estimated flow speeds in KAN-therm heating installation pipelines	[m/s]
in horizontals	do 1,0
in risers	0,2 – 0,4
in radiator connections	0,4 or more in connections without drops (to ensure pipe de-airing)

These are estimated values. The hydraulic resistance of an installation is the result of several criteria, among all, the requirement concerning maintaining the authority of thermostatic valves within the scope 0,3 – 0,7.

In small installations (single-family houses), we usually encounter the phenomenon of excessive valve authority. In such case, assume higher water speeds in pipes, to ensure that a part of the required pressure is lost within the piping.

In large installations, we usually encounter insufficient thermostatic valve authority. In such case, assume lower speeds for pipes constituting common parts of installations (horizontals, risers) and provide bigger loads to room distribution systems (made of PERT and PEXC or KAN-therm ultraLINE pipes with aluminum layer, Push pipes or KAN-therm ultraPRESS pipes with aluminum layer) or apply pressure stabilizers and increase the loads in room systems.

In KAN-therm Push installations, due to hydraulic conditions and thermal proficiency of installations, we recommend PERT and PEXC pipes with 12 mm diameters for connecting radiators up to 2000W.

Pipe diameters should be selected so that the sum of pressures in every circulation with calculated streams of heating medium is equal to the active pressure rate.

The hydraulic loads of pipe plots consist of linear loads and the sum of local resistance rates Z on the plot:

$$\Delta p_L = R \times L + Z \quad \text{where} \quad Z = \sum \zeta \times \frac{v^2 \times \rho}{2}$$

Δp [Pa]	hydraulic resistance (pressure loss)
R [Pa/m]	linear resistance (pressure loss) on the plot
L [m]	length of a pipe of a given diameter
Z [Pa]	local resistance (pressure loss) on the plot
$\sum \zeta$	sum of local resistance coefficients on the plot
v [m/s]	average flow speed inside the pipe
ρ [kg/m ³]	water density

Unit pressure loss R in KAN-therm pipes, depending on the size of the water stream and average temperature, may be calculated using suitable tables included in Appendix "Tables for hydraulic calculations in KAN-therm water supply and heating installations". The values of local resistance coefficients for fittings in particular KAN-therm systems are also presented in the tables included in the Appendix.

Additional remarks

- When conducting radiator connections in floor layers, radiators should be equipped with proper vents (manual or automatic). In the case of manifold systems, also the manifolds should be equipped with vents.
- Designing installations consisting of plastic pipes (KAN-therm ultraLINE, Push, ultraPRESS and PP), secure them against the rise (caused by failure) of water temperature above the permissible level.
- In KAN-therm heating installations, there is a possibility of using a different medium to water, e.g. anti-frost liquids. When designing such installations, consider the physical properties of these liquids, which are different to the properties of water. After that, ask for manufacturer's recommendations regarding the resistance of their pipes and joints to these substances.

3 Thermal insulation of KAN-therm installations

Depending on the type of the pipeline, thermal insulation aims at reducing the value of heat loss (in heating and hot tap water installations) or to reduce the cold loss in cooling installations. In the case of cold water installations, thermal insulation prevents water inside the installation from heating and therefore blocks condensation on the pipeline. Thermal insulation of manifold pipes in central heating, hot tap water (including circulation pipes) and cold medium installations should observe the minimal requirements specified in the table. The values presented below apply to all KAN-therm piping systems, irrespective of the material type.

Minimal thickness of thermal insulation in heating, cooling and hot tap water installations

LP	Pipe type	External diameter of KAN-therm pipes					Minimal thickness of thermal insulation ($\lambda = 0,035 \text{ W}/(\text{m} \times \text{K})^1$)
		ultraLINE	Push	ultraPRESS	Steel/Inox/Copper	PP	
1	External diameter up to 22 mm	14, 16, 20, 25	12, 14, 18, 25	14, 16, 20, 25, 26	12, 15, 18, 22	16, 20, 25, 32 (PN20)	20 mm
2	Internal diameter from 22 to 35 mm	32	32	32, 40	28, 35	32 (PN10, PN16), 40	30 mm
3	Internal diameter from 35 to 100 mm			50, 63	42; 54; 64; 66,7; 76,1; 88,9	50, 63, 75, 90, 110	equals the internal diameter of the pipe
4	Internal diameter above 100 mm				108; 139,7; 168,3		100 mm
5	Pipes and fixtures acc. to pos. 1-4 passing through walls or floor slabs, pipe crossings						½ of the requirements of pts. 1-4
6	Central heating pipes acc. to pos. 1-4, laid in structural components in between heated rooms with various users						½ of the requirements of pts. 1-4
7	Pipes acc. to pos. 6 laid in floor layer						6 mm
8	Ice-cold water installations inside buildings ²⁾						50% of the requirements of pts. 1-4
9	Ice-cold water installations outside buildings ²⁾						100% of the requirements of pts. 1-4

1) when applying insulation material with a different heat transfer coefficient than specified in the table, correct the thickness of insulation suitably,

2) thermal insulation executed as air-proof.



Notice

For KAN-therm cold water pipelines, the recommended thickness of insulation preventing water from heating and steam from condensing is provided in the table. Correct the values provided below for other values of thermal transfer coefficients of the insulation material.

Minimal thickness of thermal insulation in cold water installations

Pipeline location	Insulation thickness ($\lambda = 0,04 \text{ W}/(\text{m} \times \text{K})$)
Pipeline in non-heated room	4 mm
Pipeline in heated room	9 mm
Pipeline in channel without pipelines with warm or hot medium	4 mm
Pipeline in channel with pipelines with warm or hot medium	13 mm
Pipeline in wall furrow, vertical	4 mm
Pipeline in wall furrow, recess with pipelines with warm or hot medium	13 mm
Pipeline in floor layer (concrete screed)	4 mm

The thermal insulation material cannot have any negative impact on the pipes and joints. It should be chemically neutral in relation to the materials of these elements.

Information and safety tips

Release date of this technical information is stated on the cover. To ensure personal safety and the proper functioning of our products, you should regularly check whether there is a newer version of the technical information. Current technical information is available on the website www.kan-therm.com as well as in the nearest Technical-Commercial Office of the KAN Company.

This document is protected by copyright. The resulting laws, in particular the right to reproduce in any form are reserved. KAN Company endeavors to develop these document up to date and free of errors, however, there may be minor mistakes or inconsistencies. We reserve the right to make corrections and technical changes in this document.

When installing, observe the applicable laws, standards, guidelines and national legislation as well as any instructions contained in the technical information.

Before you begin installation, read all instructions and safety guidelines and instructions of use and installation. When they are incomprehensible or doubts arise about their meaning, please contact the nearest Technical – Commercial Office of KAN. Provided installation and operating instructions should be preserved and handed over to future participants in the construction process or installation owner. Failure to follow the guidelines given in this document can lead to failure and damage to property or injuries.

1.1 Intended use

KAN-therm system must be designed, installed and operated in the manner described in this technical information and in accordance with applicable regulations. Other uses are unacceptable and will be considered as improper use of the products. This applies to both elements for the construction of piping systems and tools used for making connections.

Despite the use of the highest quality materials, KAN can not ensure their adequacy for every application. It should be noted that in the case of water transport of high aggressiveness - high content of dissolved hydrogen bicarbonate or chloride can affect the brass alloys and accelerate their corrosion. In particular, do not exceed the permissible concentrations:

- chlorine ions (Cl^-) ≤ 200 mg/l
- sulfate ions (SO_4^{2-}) ≤ 250 mg/l
- calcium carbonate ions (CaCO_3^{2-}) ≤ 5 mg/l at $\text{pH} \geq 7,7$

For applications that are not included in this technical information (custom application), you should contact the Technical-Commercial Office of KAN to confirm possibility of such application.

1.2 Qualifications of participants in the construction process

Installation of KAN-therm systems should be performed only by trained and authorized personnel with appropriate qualifications.

1.3 General precautions

Workplace and used parts and tools for making connections should be kept clean and in proper condition. Use only original parts of KAN-therm provided for the type of connection and purpose. Use of not original elements or an unauthorized tools, the use of components for other applications than those provided or cross their operating parameters limits can lead to failure, accidents or other hazards.



THE PRODUCTS WITH THE LABEL KAN-therm ARE DISTRIBUTED TO 65 COUNTRIES IN THE WORLD.

The distribution network covers Europe, a large part
of Asia and also reaches Africa and America.



KAN Group

kan-therm.com

Complete multipurpose installation system consisting of modern, mutually complementary technical solutions for pipe water distribution, heating and cooling installations, as well as technological and fire extinguishing ones.

ultra**LINE**

ultra**PRESS**

PP

Steel

Inox

Copper, Copper Gas

XPress Sprinkler

**Surface heating and cooling
and automation**

**Football
Stadium installations**

**Cabinets
and manifolds**

